



NextFEM Designer
Validation of scaffold analysis and
verifications

Version 1.7

© NextFEM 2015-2021

Summary

Chapter 1 Introduction	4
Design codes	4
Chapter 2 Analysis validation	5
Types of analysis.....	5
Static analysis	5
Origin and features of the program.....	5
Realiability of the program	5
Tutorial One	6
Tutorial Two	16
Case a.....	16
Case b	22
Tutorial Three	27
Tutorial Four.....	30
Tutorial Five.....	34
Tutorial Six.....	38
Chapter 3 Verifications for steel scaffolds	42
Symbols.....	42
Verification listing	43
Estimation of section class	43
Tension/compression (Axial).....	43
Shear (Shear).....	44
Bending with shear interaction (Bending).....	44
Biaxial bending and axial load (TensBending_biax and BuckBending_biax)	44
Torsional buckling (TorsionBuckling).....	45
Combined torsional buckling (TorsionBuck_comb).....	45
Deflection checks.....	45
Joint checks.....	45
Appendix 1 – Checking example.....	47
Chapter 4 Verifications for aluminium scaffolds	52
Symbols.....	52
Verification listing	53
Estimation of section class	53
Tension/compression (Axial).....	54
Shear (Shear).....	54
Bending with shear interaction (Bending).....	55

Biaxial bending and axial load (BuckBending_biax and TensBending_biax)	55
Torsional buckling (TorsionBuckling)	55
Combined torsional buckling (TorsionBuck_comb)	56
Deflection checks	56
Joint checks	56
Appendix 2 – Checking example	58

Chapter 1

Introduction

As requested by several codes of practice, the structural verifications of a scaffold are compulsory beyond a certain height. In this manual, analysis and verifications conducted with NextFEM Designer are showed and validated.

In the second paragraph, the program validation will be presented against some cases having easy analytical solution.

In the third paragraph, relationships used for steel member checking will be presented, with particular reference to scaffolds and decks.

Such manual applies to the linear (static and dynamic) analyses only carried out with *NextFEM Designer* and with its predefined solver (*OOFEM*).

Design codes

The following references have been used:

1. EN 1993-1-1: Eurocode 3 - Design of steel structures - Part 1-1: General rules and rules for buildings
2. EN 12811-1: Temporary works equipment - Part 1: Scaffolds - Performance requirements and general design.

Chapter 2

Analysis validation

In the following paragraph, a validation for structural analysis conducted with *NextFEM Designer* will be presented.

Types of analysis

Static analysis

The analysis performed is a structural static analysis. The solution of linear system of equations in the form $Ax=b$, produced by the Finite Elements Method, is obtained with linear systems solvers.

Load combinations are consistent with the ones proposed by Eurocode 3, and are written in the following form:

$$\gamma_{G1} \cdot G_1 + \gamma_{G2} \cdot G_2 + \gamma_{Q1} \cdot Q_{k1} + \gamma_{Q2} \cdot \psi_{02} \cdot Q_{k2} + \gamma_{Q3} \cdot \psi_{03} \cdot Q_{k3} + \dots$$

Partial safety factors:

- γ_{G1} : for self-weight loads, set as default to 1.5
- γ_{G2} : for permanent loads, set as default to 1.5
- γ_{Qi} : for variable loading, set as default to 1.5

Combination factors:

- ψ_{0i} : as default to 0.7 for variable loading
- ψ_{0i} : as default to 0.6 for wind loads
- ψ_{0i} : as default to 0.5 for snow loads (on the base of the height of the building site, < 1000m s.l.m.)

Such ULS (Ultimate Limit State) combinations are automatically generated by the program through the command **Assign/Load combinations.../Generate combos**. Please refer to the program users' manual for further informations.

Origin and features of the program

The program is composed by 2 parts:

- Pre- and post-processor, NextFEM Designer (the program seen by the user), which handles input phase and results visualization, and also load combinations generation and verifications. This program is licensed to final user with the included license, that can be obtained with the command **!/About.../Product license**. *NextFEM Designer* is made by NextFEM, except for the packages listed in **!/About...**
- The default solver, *OOFEM*, is employed to perform the Finite Elements calculations. Other types of solvers can be set and used in the program, by they are not supported for this validation. *OOFEM* is licensed under LGPL conditions, reported in **!/About...** and included in the software package. This solver is developed by Prof. Borek Patzak (University of Prague) and by the *oofem.org* community.

Reliability of the program

This validation, including the hand calculation presented, is reported at Chapter 5 of the **users' manual of NextFEM Designer**. In the following, a reduced version with a particular focus on frame structures is reported.

Tutorial One

This tutorial will show how to model a 5 metres long fixed-ended beam, loaded with concentrated loads of 10kN in directions x , y and z in the middle of its span. The results from NextFEM Designer (Frame forces and displacement) are compared with hand calculations.

⚠ WARNING: Both flexural and shear deformations are considered. To enable this option, click on Tools>Option>Solver and check the Include shear deformations in beam elements tick under the OOFEM preferences box

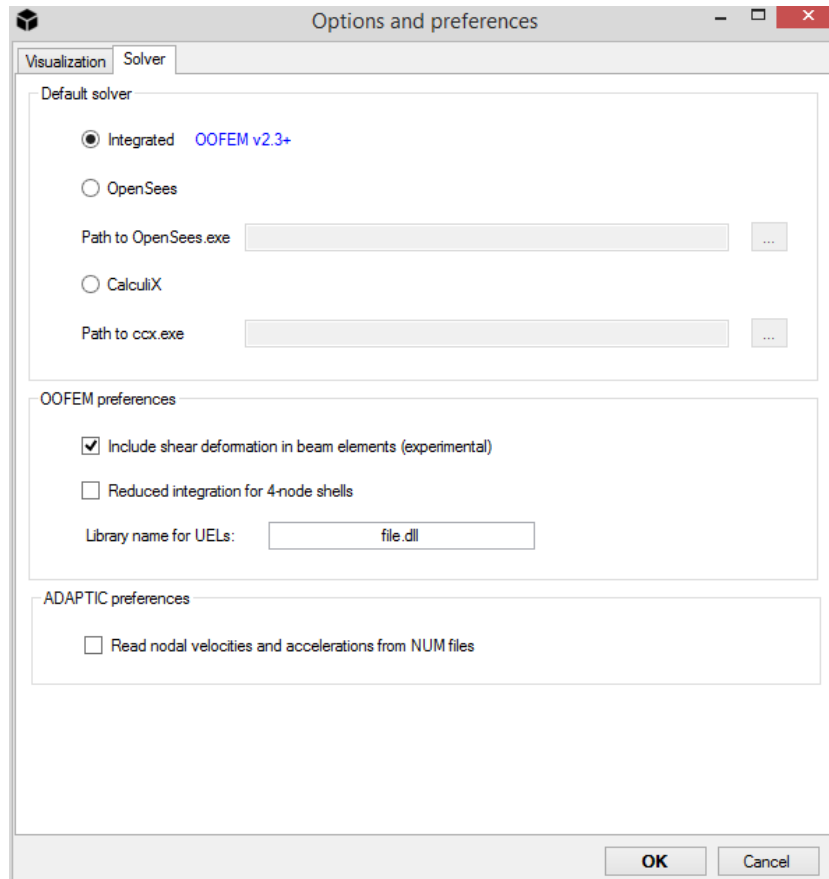

The following sequence of operations are needed to create the model:

1. Set the Units: N for force and mm for length.

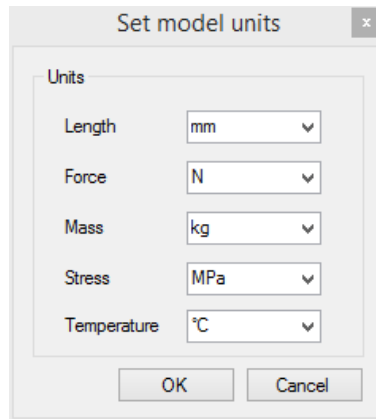

2. Define the Material properties:
 - Name: Concrete;
 - $E=30000 \text{ N/mm}^2$;
 - $\nu=0.3$
 - $F_k=25 \text{ N/mm}$
 - $\text{Weight}=2.5\text{e-}5 \text{ N/mm}^3$;
 - $\text{Mass}=2.55\text{e-}9 \text{ N/mm}^2/\text{g}$

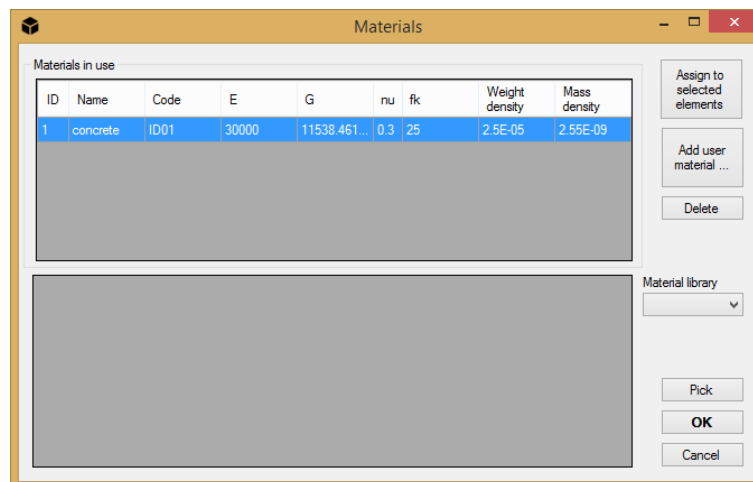

3. Define the Section properties:
 - $b=300 \text{ mm}$ (z direction);
 - $h=500\text{mm}$ (y direction);

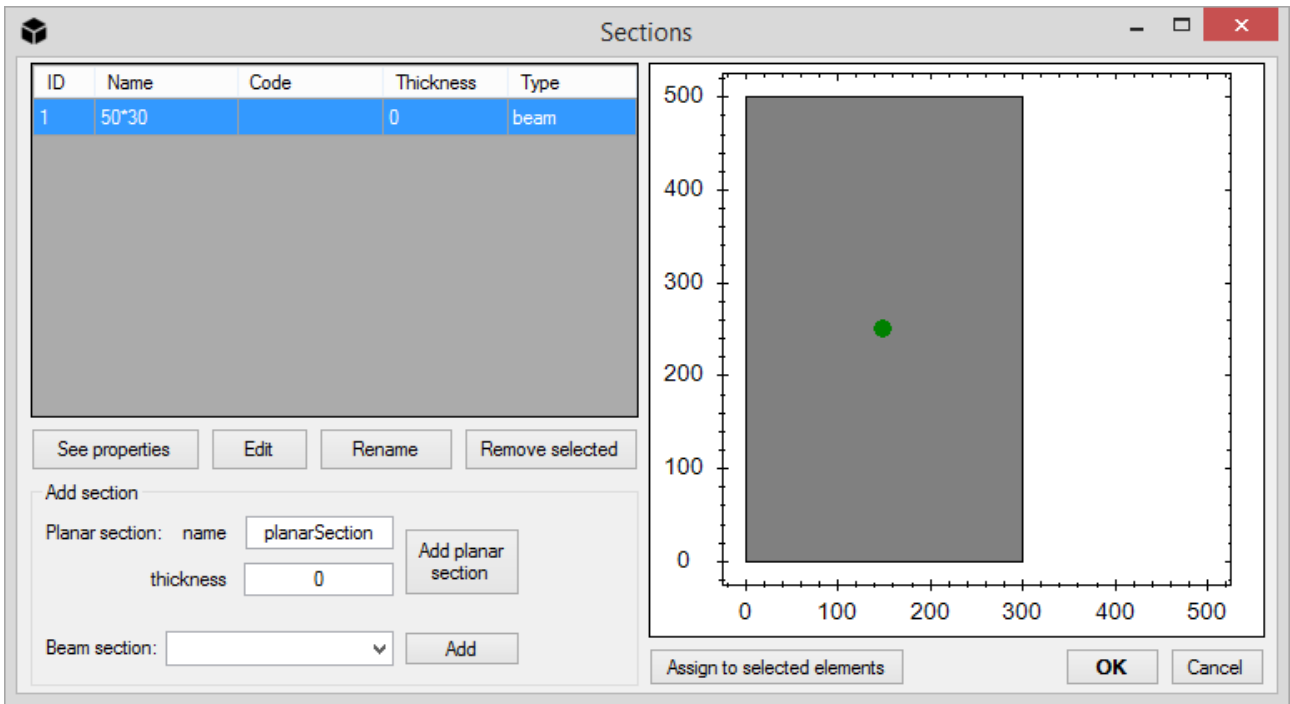

4. Define the Loads cases: Only one load case called *Qk1* is considered

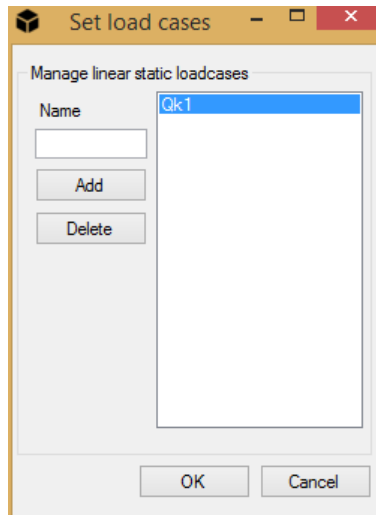

5. Insert the Geometric properties using *Node by Coordinates*:

- o L=5000 mm;
- o Distance from fixed end to loads=2500 mm;

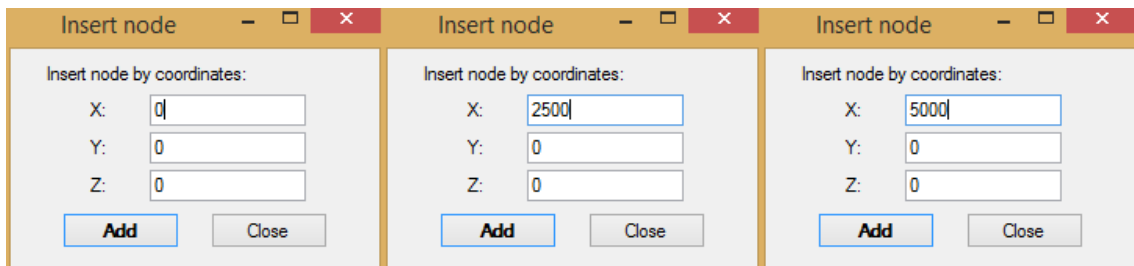

6. Insert the beams using the *Beam* command.

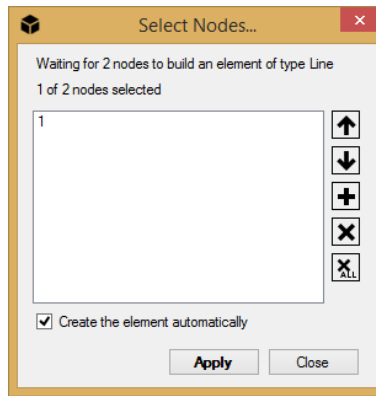

7. Assign the boundary conditions using the *Restraints* command: fix all DoFs for nodes 1 and 3.

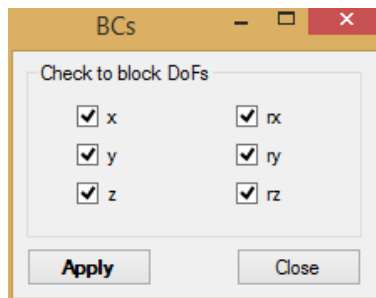

8. Assign the material using the *Assign>Material* command at the beams by selecting them and then click on *Assign to selected elements*

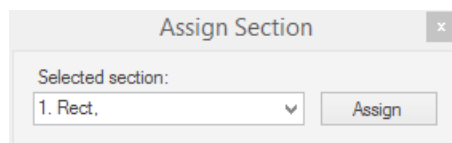

9. Assign the section using the *Assign>Section* command at the beams by selecting them and then click on *Assign*

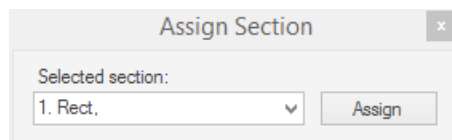

10. Assign the point load to the node number 2.
- o $P_x=10000$ N;
 - o $P_y=10000$ N;
 - o $P_z=-10000$ N.

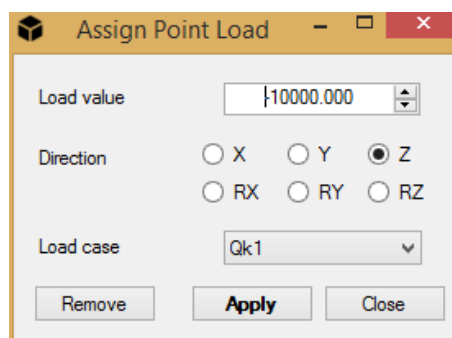

11. Run the analysis.

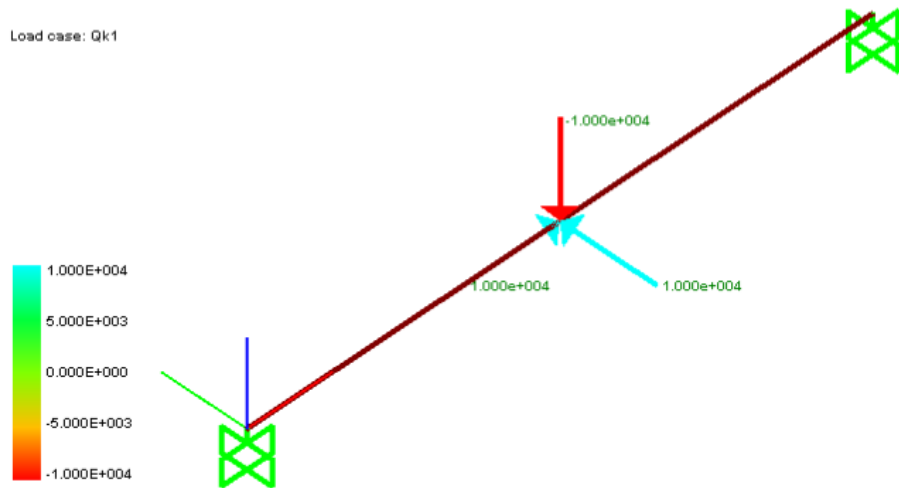

- NextFEM Designer's Results:

- o Displacement in x direction: Node 2= 0.002778mm

Node Displacements
Component: x

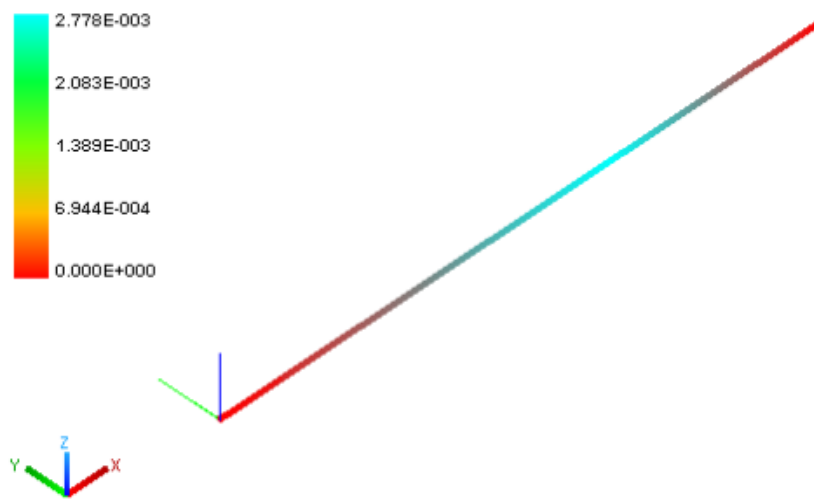

- o Displacement in y direction: Node 2= 0.2016mm

Node Displacements
Component: y

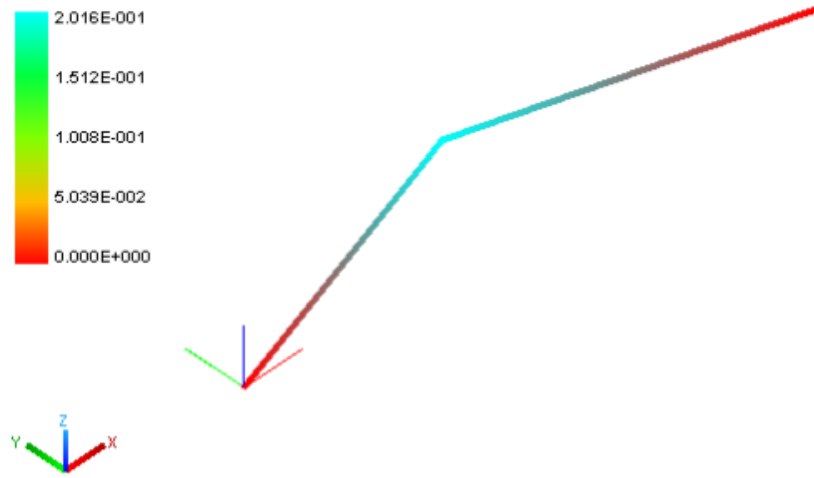

- Displacement in z direction: Node 2=-0.00781 mm

Node Displacements
Component: z

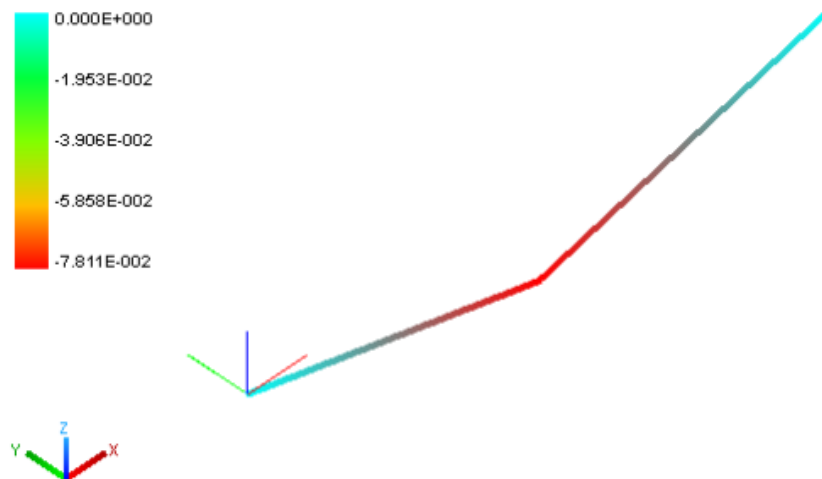

- Moment Diagram: Values from *Results>Extract Data*
 - Mzz

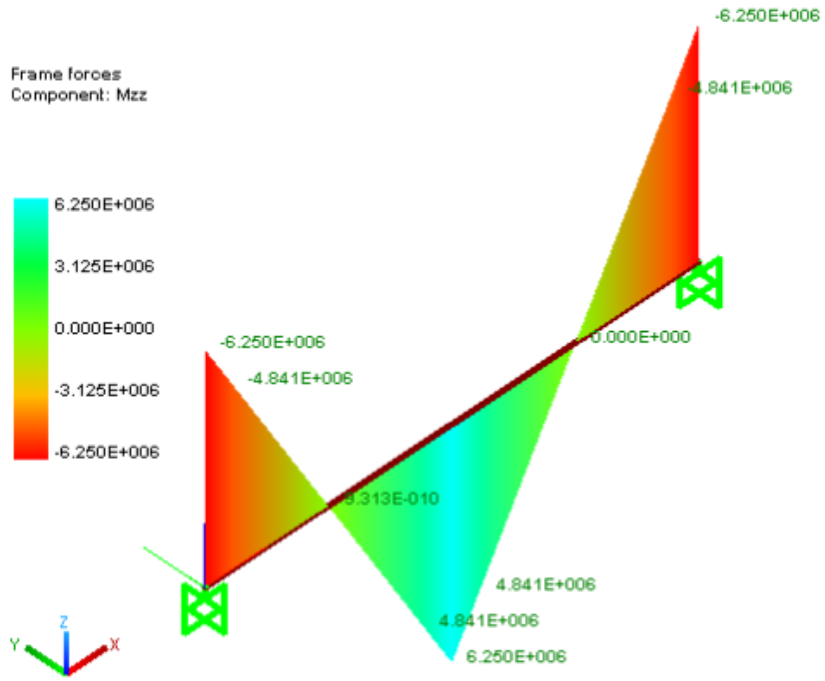

- Myy

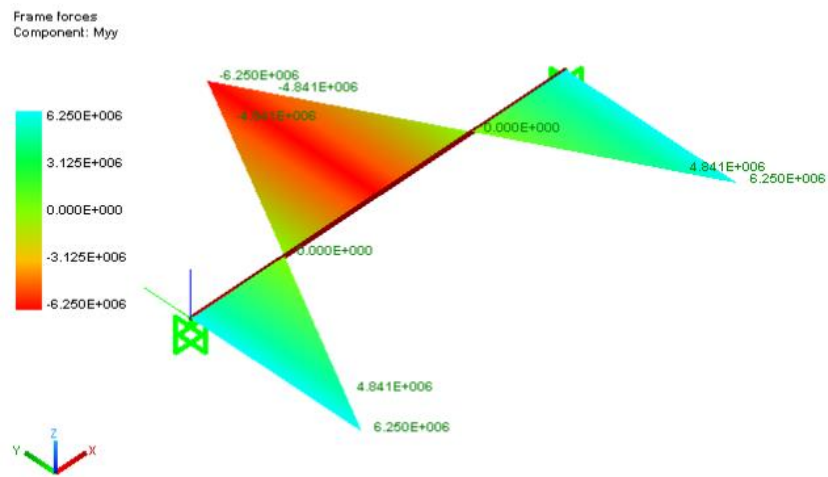

- Shear Diagram:

- Vy

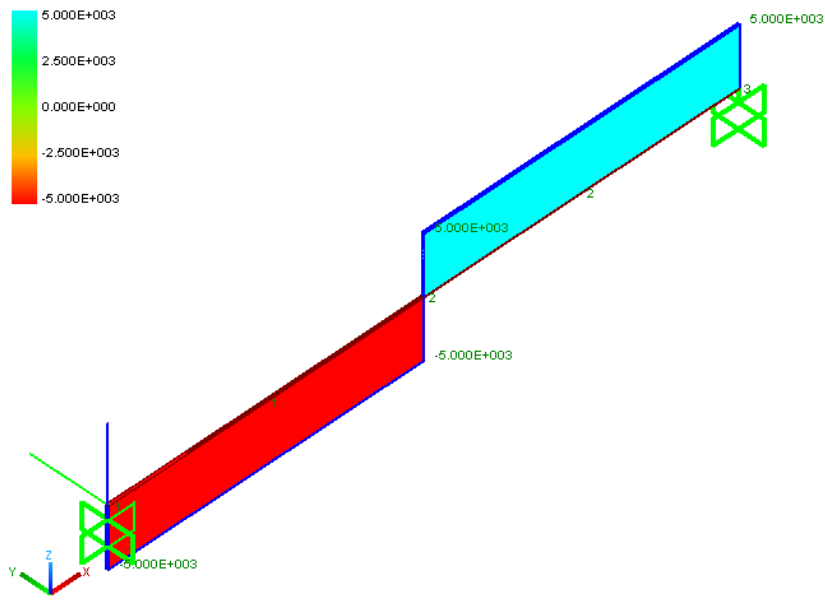

■ Vz

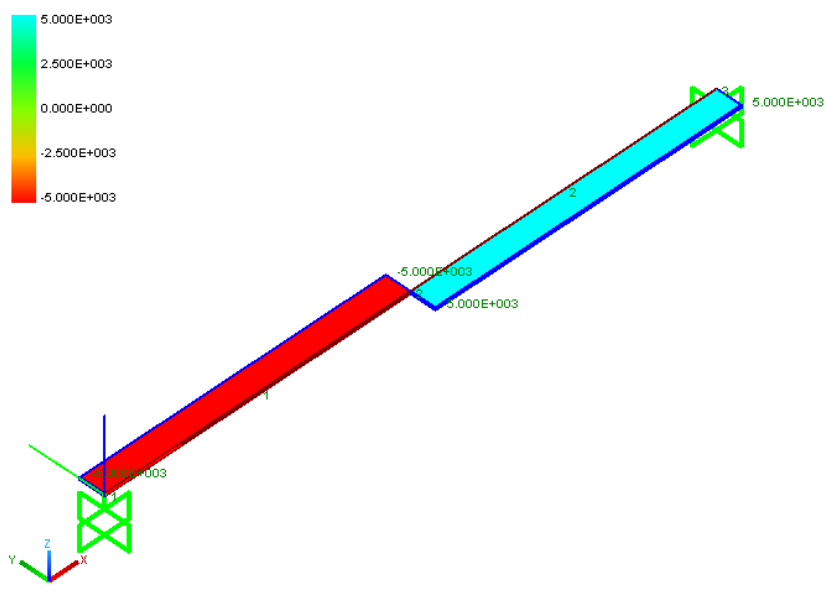

○ Normal forces Diagram:

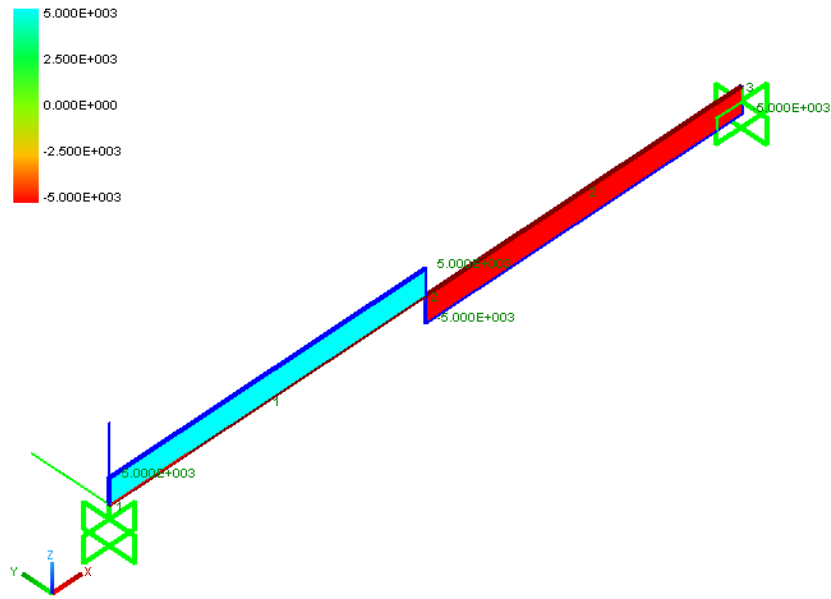

- o Internal displacements in y direction: values from *Results>Extract data*

Position [mm]	Displacement [mm]
0	0
281.8	0.00778
1250	0.1008
2218	0.1938
2500	0.2016
2500	0.2016
2781.8	0.1938
3750	0.1008
4718	0.00778
5000	0

- o Internal displacements in z direction: values from *Results>Extract data*

Position [mm]	Displacement [mm]
0	0
281.8	-0.003424
1250	-0.03906
2218	-0.07469
2500	-0.07811
2500	-0.07811
2781.8	-0.07469
3750	-0.03906
4718	-0.003424
5000	0

- Hand Calculations:

- o Section properties

$$A = b \cdot h = 150000 \text{mm}^2$$

$$J_y = \frac{bh^3}{12} = 3125e6 \text{mm}^4$$

$$J_z = \frac{hb^3}{12} = 1125e6 \text{mm}^4$$

- Moment diagram:

- M_{zz}

$$M_{\max} = \frac{P_z l}{8} = 6250000 \text{ Nmm}; M_{\min} = -\frac{P_z l}{8} = -6250000 \text{ Nmm}$$

- M_{yy}

$$M_{\max} = \frac{P_y l}{8} = 6250000 \text{ Nmm}; M_{\min} = -\frac{P_y l}{8} = -6250000 \text{ Nmm}$$

- Shear Diagram:

- V_y

$$V_{\max} = \frac{P_z}{2} = 5000 \text{ N}; V_{\min} = -\frac{P_z}{2} = -5000 \text{ N}$$

- V_z

$$V_{\max} = \frac{P_y}{2} = 5000 \text{ N}; V_{\min} = -\frac{P_y}{2} = -5000 \text{ N}$$

- Axial force Diagram:

$$N_{\max} = \frac{P_x}{2} = 5000 \text{ N}; N_{\min} = -\frac{P_x}{2} = -5000 \text{ N}$$

- Displacement in x direction: Node 2

$$u_{2,x} = \frac{N_{\max}(l/2)}{EA} = 0.00278 \text{ mm}$$

- Displacement in y direction: Node 2

$$u_{2,y} = \frac{1}{192} \frac{P_y l^3}{EJ_z} + \chi \frac{P_y l}{4GA} = 0.201568 \text{ mm}$$

- Displacement in z direction: Node 2

$$u_{2,z} = \frac{1}{192} \frac{P_z l^3}{EJ_y} + \chi \frac{P_z l}{4GA} = -0.07811 \text{ mm}$$

- Displacement in y direction: internal point at the coordinate x

$$u_{x,y} = \frac{1}{24} \frac{P_y x^2 \left(\frac{3}{2} l - 2x \right)}{EJ_z} + \chi \frac{P_y x}{2GA} \text{ for } 0 \leq x \leq L/2$$

$$u_{x,y} = \frac{1}{24} \frac{P_y (L-x)^2 \left(2x - \frac{L}{2} \right)}{EJ_z} + \chi \frac{P_y (L-x)}{2GA} \text{ for } L/2 \leq x \leq L$$

Position [mm]	Displacement [mm]
0	0
281.8	0.00778
1250	0.1008
2218	0.1938
2500	0.2016
2500	0.2016
2781.8	0.1938

3750	0.1008
4718	0.00779
5000	0

- o Displacement in z direction: internal point at the coordinate x

$$u_{x,z} = \frac{1}{24} \frac{P_z x^2 \left(\frac{3}{2}l - 2x \right)}{EJ_y} + \chi \frac{P_z x}{2GA} \text{ for } 0 \leq x \leq L/2$$

$$u_{x,z} = \frac{1}{24} \frac{P_z (L-x)^2 \left(2x - \frac{L}{2} \right)}{EJ_y} + \chi \frac{P_z (L-x)}{2GA} \text{ for } L/2 \leq x \leq L$$

Position [mm]	Displacement [mm]
0	0
281.8	-0.003425
1250	-0.03906
2218	-0.07468
2500	-0.07811
2500	-0.07811
2781.8	-0.07469
3750	-0.03906
4718	-0.003429
5000	0

Tutorial Two

The second tutorial consists in a cantilever beam loaded with points load in directions y and z. The output results of NextFEM Designer (Frame forces and displacement) are compared with hand calculations.

Case a

Only flexural deformations are considered.

- Units: N for forces and mm for lengths.
- Material Properties:
 - o Name: Concrete;
 - o E=30000 N/mm²;
 - o Nu=0.3
 - o Fk=25 N/mm
 - o Weight=2.5e-5 N/mm³;
 - o Mass=2.55e-9 N/mm²/g
- Section properties:
 - o B=300 mm (z direction);
 - o H=500mm (y direction);
- Geometric properties:
 - o L=2500 mm;
- Loads:
 - o Py=5000 N;
 - o Pz=-10000 N.

Load case: Qk1

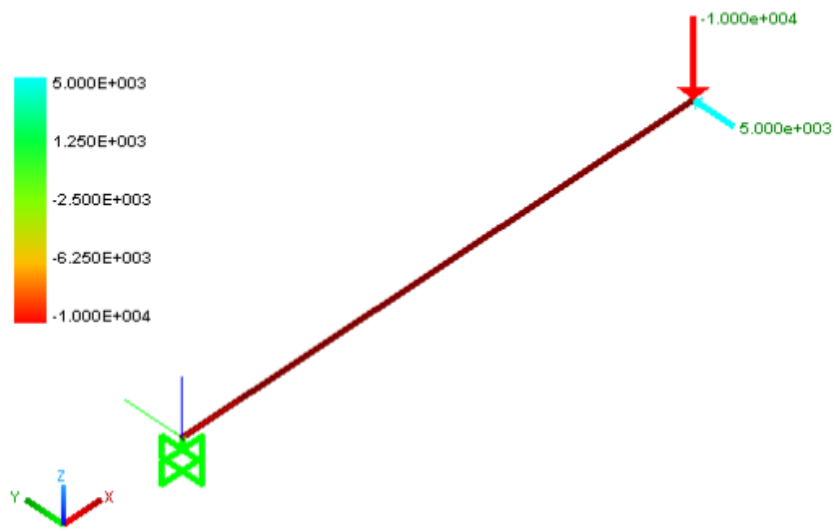

- NextFEM Designer's results:

- o Displacement in x direction: Node 2=0.00mm

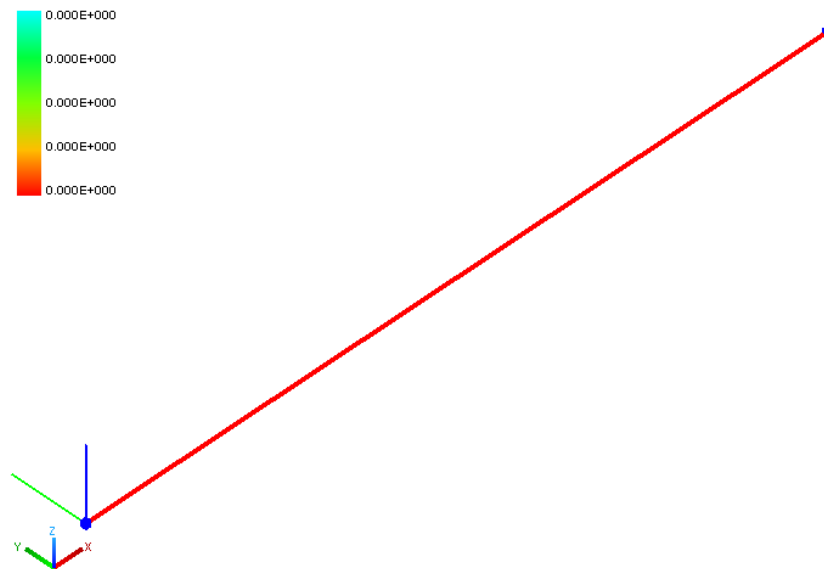

- o Displacement in y direction: Node 2=0.7716mm

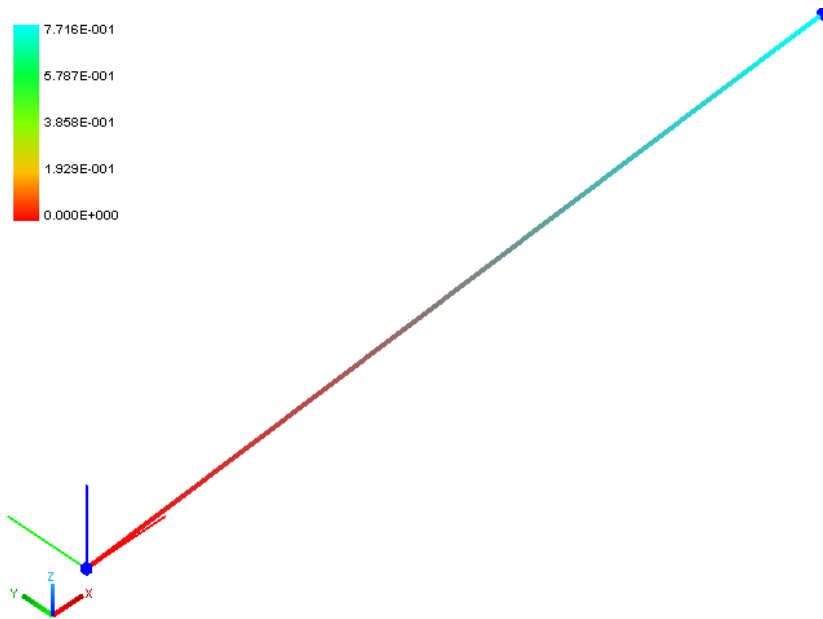

- o Displacement in z direction: Node 2=-0.5556mm

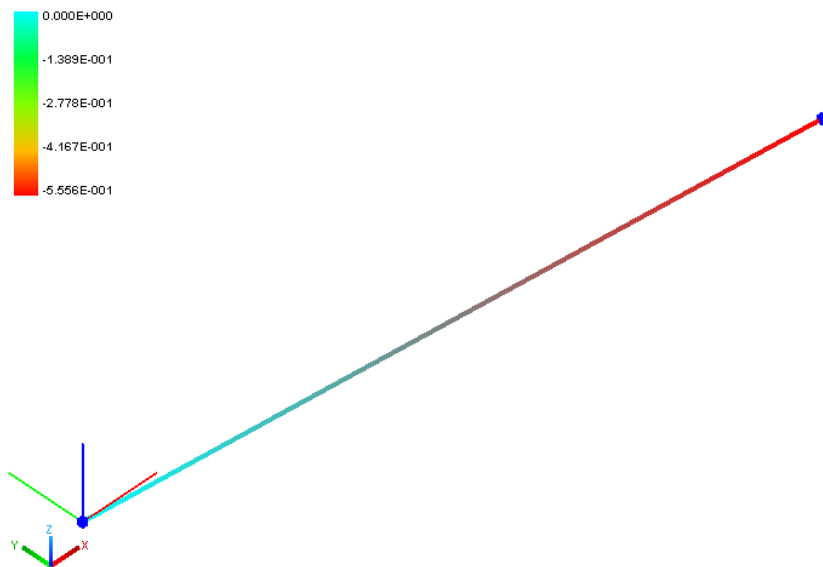

- o Moment Diagram: Values from *Results>Extract Data*
 - Mzz

Frame forces
Component: Mzz

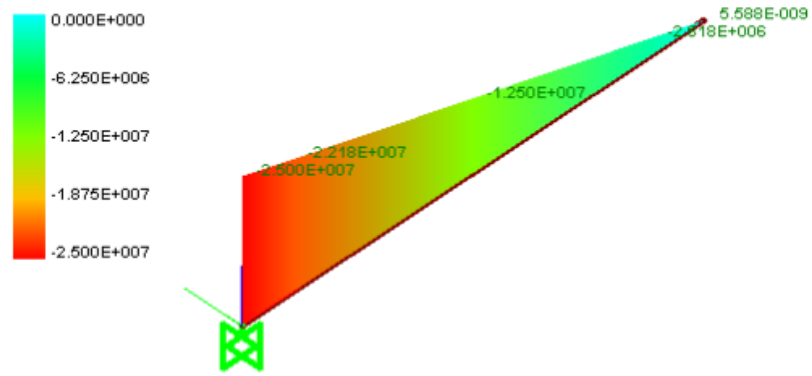

Y Z X
Myy

Frame forces
Component: Myy

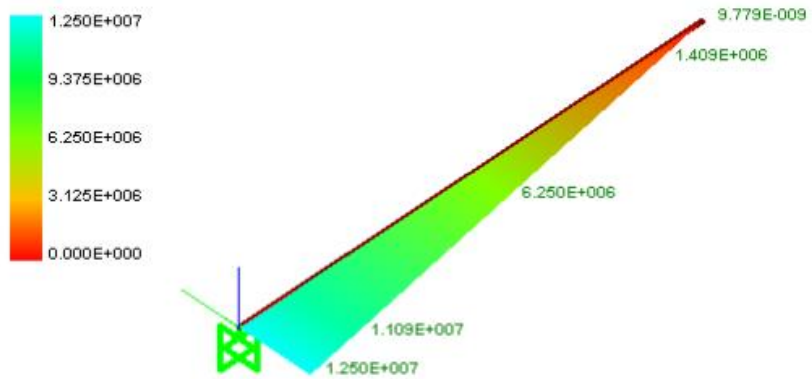

Y Z X

- o Shear Diagram:
 - V_y

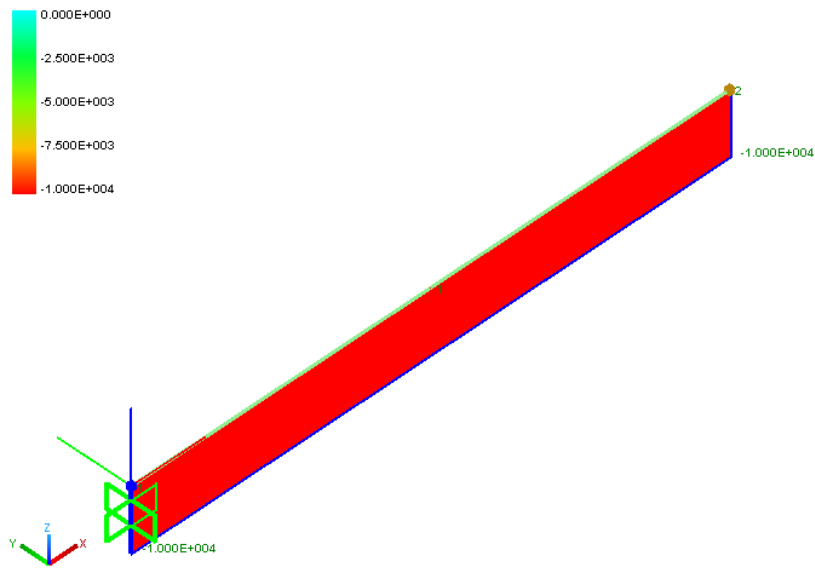

■ Vz

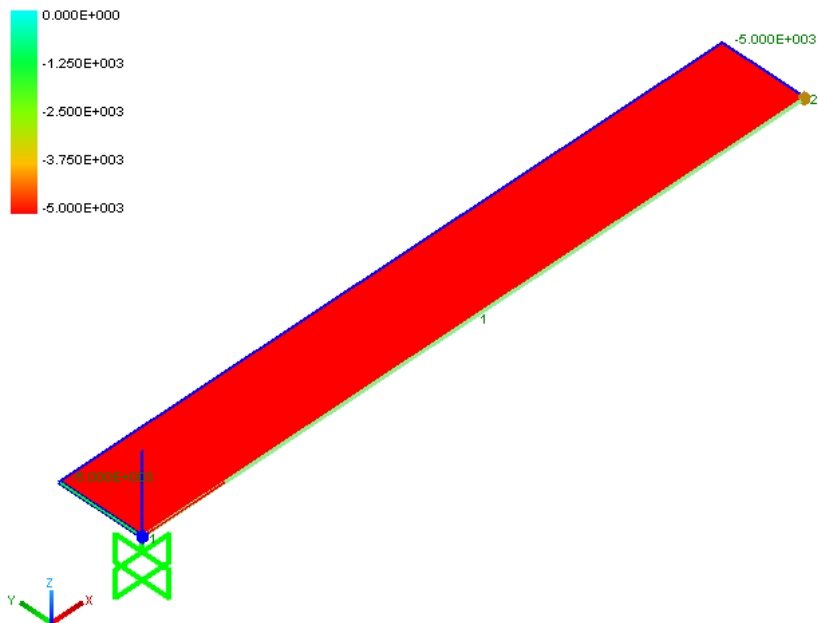

- o Internal displacement in y direction: values from *Results>Extract data*

Position [mm]	Displacement [mm]
0	0
281.8	0.01415
1250	0.2411
2218	0.6417
2500	0.7716

- o Internal displacement in z direction: values from *Results>Extract data*

Position [mm]	Displacement [mm]
0	0
281.8	-0.01019
1250	-0.1736

2218	-0.4620
2500	-0.5556

- Hand Calculations:

- o Moment diagram:

- Mzz

$$M_{\max} = P_z l = 25000000 \text{ Nmm} ;$$

- Myy

$$M_{\max} = P_y l = 12500000 \text{ Nmm}$$

- o Shear Diagram:

- Vy

$$V_{\max} = P_z = 10000 \text{ N} ;$$

- Vz

$$V_{\max} = P_y = 5000 \text{ N} ;$$

- o Axial force Diagram:

$$N_{\max} = 0 \text{ N} ;$$

- o Displacement in x direction: Node 2

$$u_{2,x} = 0$$

- o Displacement in y direction: Node 2

$$u_{2,y} = \frac{1}{3} \frac{P_y l^3}{E J_z} = 0.77160 \text{ mm}$$

- o Displacement in z direction: Node 2

$$u_{2,z} = \frac{1}{3} \frac{P_z l^3}{E J_y} = -0.0.5556 \text{ mm}$$

- o Displacement in y direction: point at coordinate x

$$u_{x,y} = \frac{1}{6} \frac{P_y x^2 (3l - x)}{E J_z}$$

Coordinate x [mm]	Displacement [mm]
0	0
281.8	0.01415
1250	0.2411
2218	0.6416
2500	0.7716

- o Displacement in z direction: point at coordinate x

$$u_{x,z} = \frac{1}{6} \frac{P_z x^2 (3l - x)}{E J_y}$$

Coordinate x [mm]	Displacement [mm]
0	0
281.8	-0.01019
1250	-0.1736
2218	-0.4620
2500	-0.5556

Case b

⚠ Both flexural and shear deformations are considered. To enable this option, click on *Tools>Option>Solver* and check the *Include shear deformations in beam elements* tick under the *OOFEM preferences box*

- Units: N for forces and mm for lengths.
- Material Properties:
 - o Name: Concrete;
 - o $E=30000 \text{ N/mm}^2$;
 - o $\nu=0.3$
 - o $F_k=25 \text{ N/mm}$
 - o $\text{Weight}=2.5e-5 \text{ N/mm}^3$;
 - o $\text{Mass}=2.55e-9 \text{ N/mm}^2/\text{g}$
- Section properties:
 - o $B=300 \text{ mm}$ (z direction);
 - o $H=500\text{mm}$ (y direction);
- Geometric properties:
 - o $L=2500 \text{ mm}$;
- Loads:
 - o $P_y=5000 \text{ N}$;
 - o $P_z=-10000 \text{ N}$.

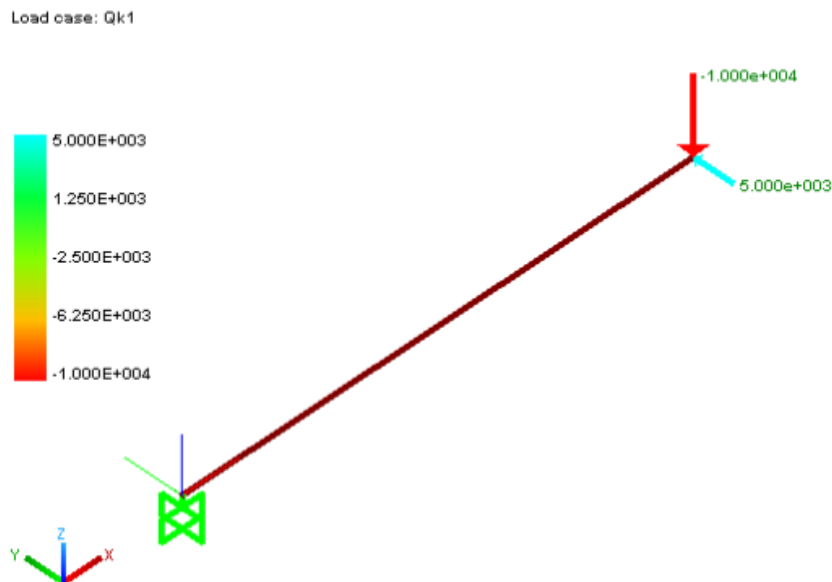

- NextFEM Designer's results:
 - o Displacement in x direction: Node 2=0.00mm

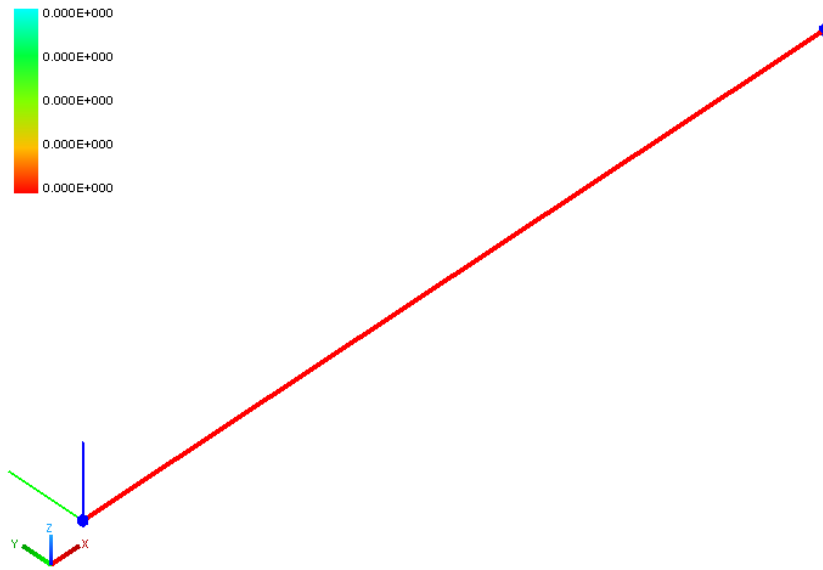

- o Displacement in y direction: Node 2=0.7803mm

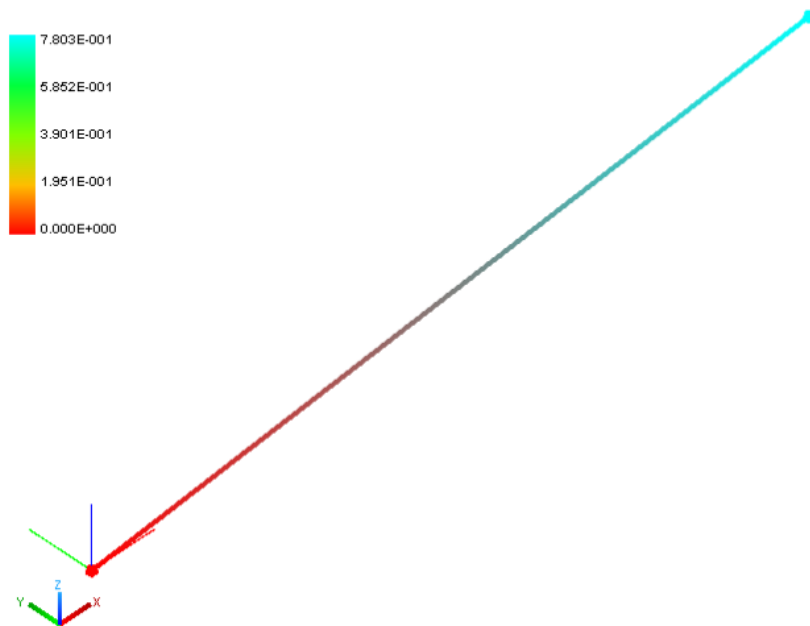

- o Displacement in z direction: Node 2=-0.5729mm

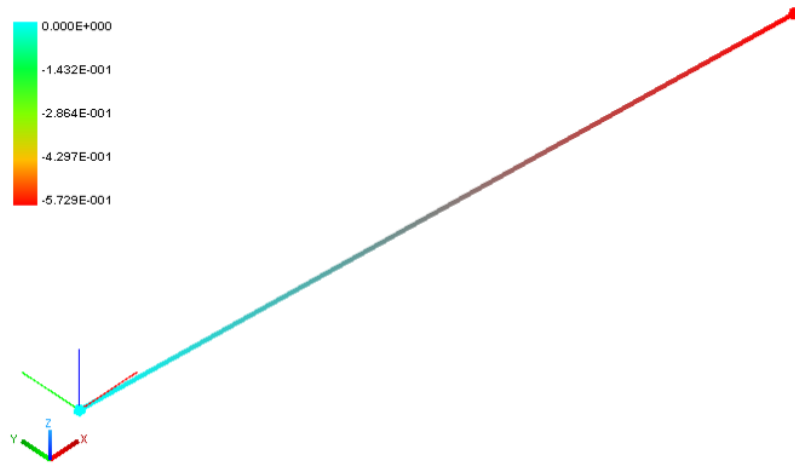

- Moment Diagram: Values from *Results>Extract Data*
 - Mzz

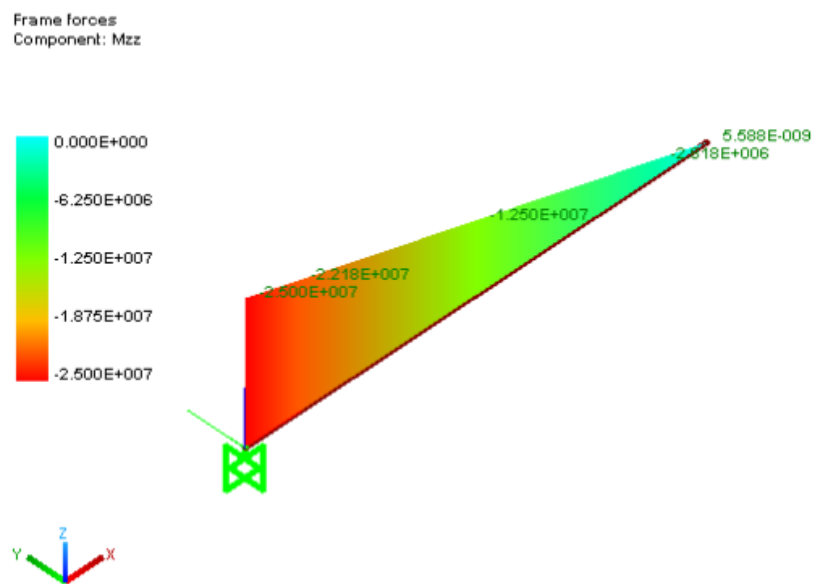

- Myy

Frame forces
Component: Myy

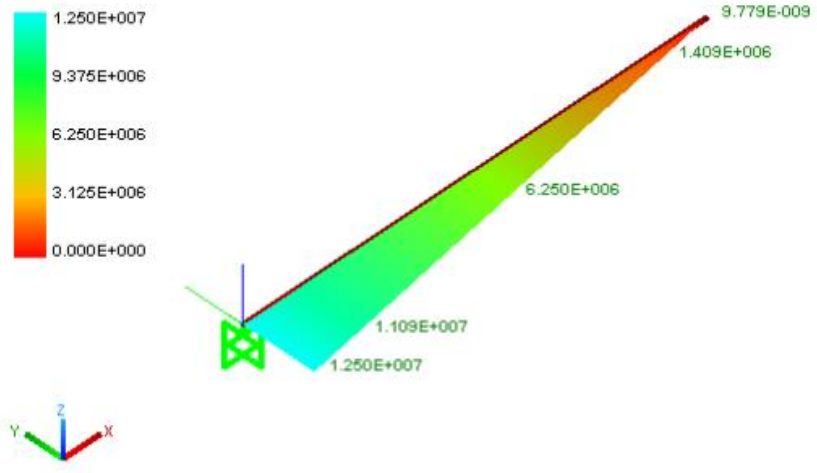

o Shear Diagram:

▪ Vy

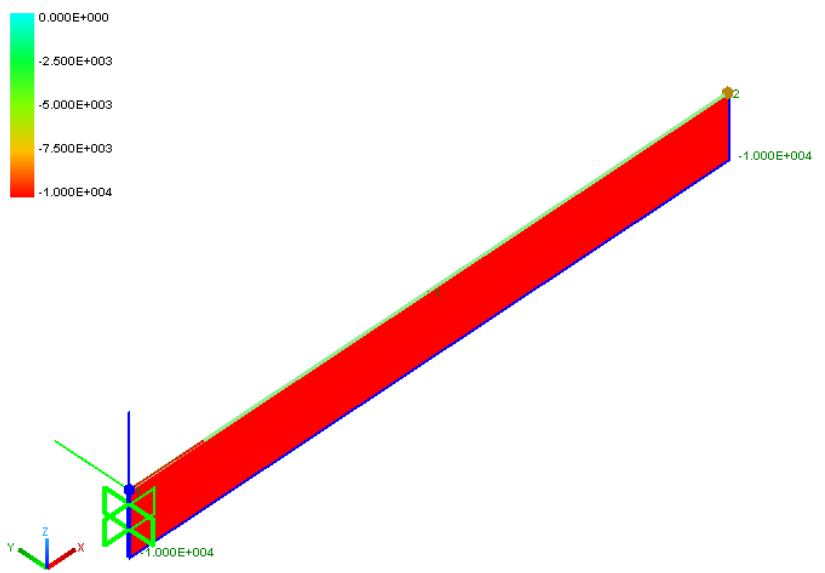

▪ Vz

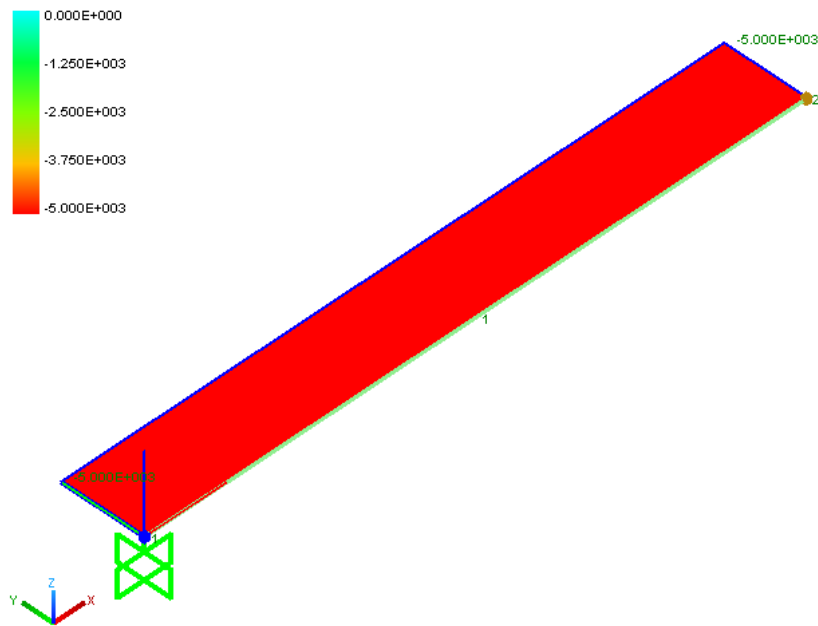

- Internal displacement in y direction: values from *Results>Extract data*

Position [mm]	Displacement [mm]
0	0
281.8	0.01513
1250	0.2455
2218	0.6494
2500	0.7803

- Internal displacement in z direction: values from *Results>Extract data*

Position [mm]	Displacement [mm]
0	0
281.8	-0.01214
1250	-0.1823
2218	-0.4774
2500	-0.5729

- Hand Calculations:

- Moment diagram:

- M_{zz}

$$M_{\max} = P_z l = 25000000 \text{ Nmm} ;$$

- M_{yy}

$$M_{\max} = P_y l = 12500000 \text{ Nmm}$$

- Shear Diagram:

- V_y

$$V_{\max} = P_z = 10000 \text{ N} ;$$

- V_z

$$V_{\max} = P_y = 5000N ;$$

- o Axial force Diagram:

$$N_{\max} = 0N ;$$

- o Displacement in x direction: Node 2

$$u_{2,x} = 0mm$$

- o Displacement in y direction: Node 2

$$u_{2,y} = \frac{1}{3} \frac{P_y l^3}{EJ_z} + \chi \frac{P_y l}{GA} = 0.7803mm$$

- o Displacement in y direction: point at coordinate x

$$u_{x,y} = \frac{1}{6} \frac{P_y x^2 (3l - x)}{EJ_z} + \chi \frac{P_y x}{GA}$$

Coordinate x [mm]	Displacement [mm]
0	0
281.8	0.01513
1250	0.2455
2218	0.6493
2500	0.7803

- o Displacement in z direction: Node 2

$$u_{2,z} = \frac{1}{3} \frac{P_z l^3}{EJ_y} + \chi \frac{P_z l}{GA} = -0.5729mm$$

- o displacement in z direction: point at coordinate x

$$u_{x,z} = \frac{1}{6} \frac{P_z x^2 (3l - x)}{EJ_y} + \chi \frac{P_z x}{GA}$$

Coordinate x [mm]	Displacement [mm]
0	0
281.8	-0.01214
1250	-0.1823
2218	-0.4773
2500	-0.5729

Tutorial Three

The third tutorial consists in a cantilever beam loaded with points load in direction y with modelled by shell elements (Mindlin-Reissner theory). The output results of NextFEM Designer (Frame forces and displacement) are compared with hand calculations.

⚠ Only flexural deformations are considered.

- Units: N for forces and mm for lengths.
- Material Properties:
 - o Name: Concrete;
 - o $E=30000 \text{ N/mm}^2$;
 - o $\nu=0.3$
 - o $F_k=25 \text{ N/mm}$
 - o $\text{Weight}=2.5e-5 \text{ N/mm}^3$;
 - o $\text{Mass}=2.55e-9 \text{ N/mm}^2/\text{g}$
- Section properties:
 - o $B=300 \text{ mm}$ (y direction); Planar section;
- Geometric properties:
 - o $L=5000 \text{ mm}$;
- Loads:
 - o $P_y=5000 \text{ N}$;
 - o $P_z=10000 \text{ N}$;
- Mesh size: $250 \times 250 \text{ mm}$

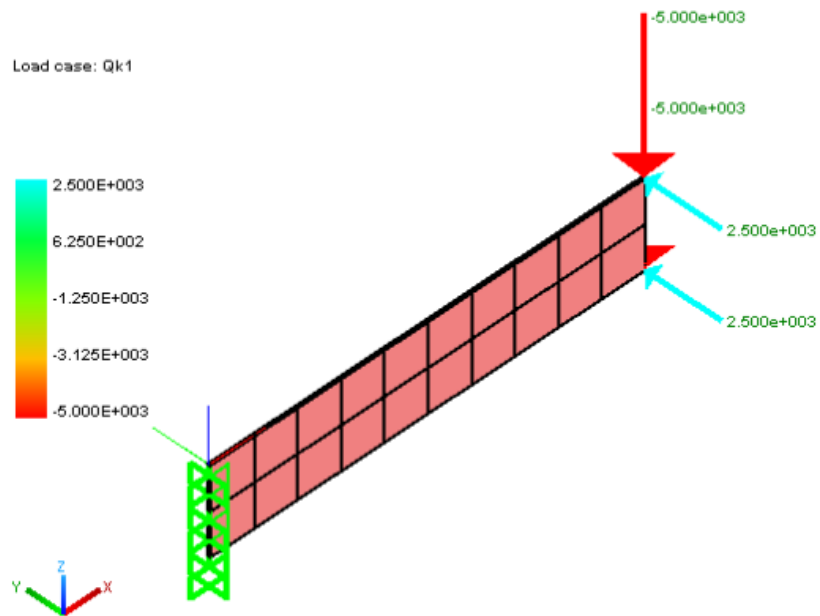

- NextFEM Designer's Results:
 - o Displacement in x direction: Node 2= 0.00 mm

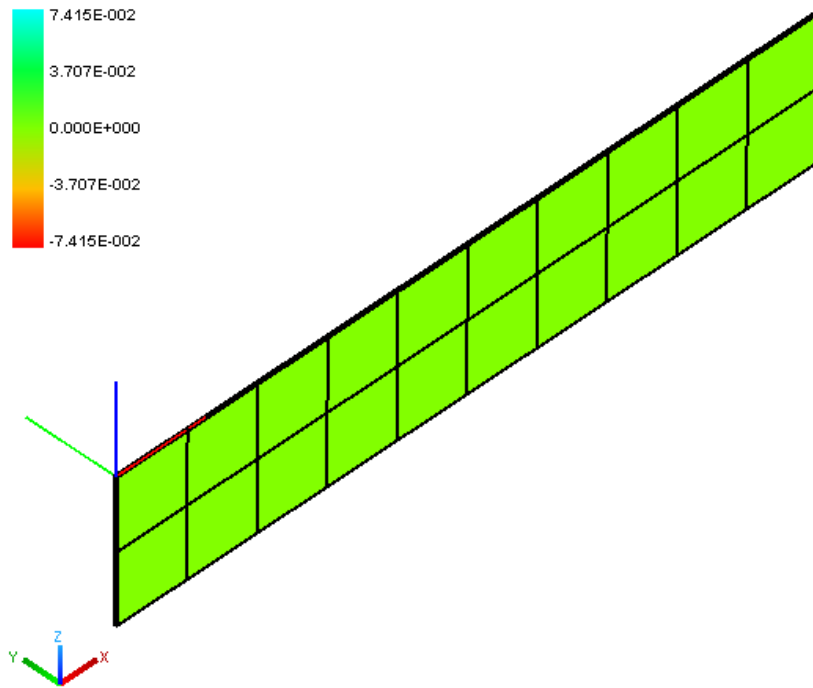

- o Displacement in y direction: Node 2=-0.6250 mm

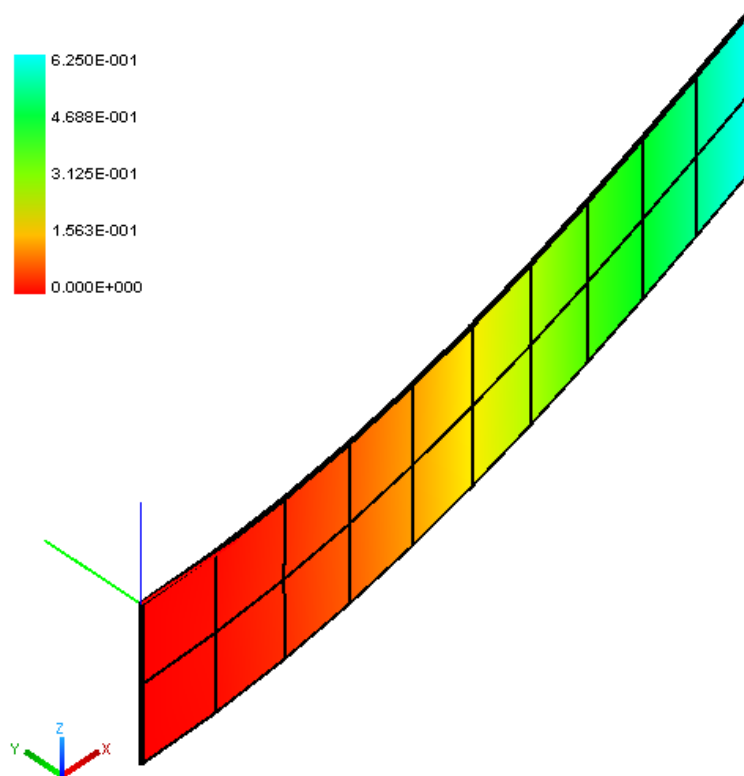

- o Displacement in z direction: Node 2=-0.5062mm

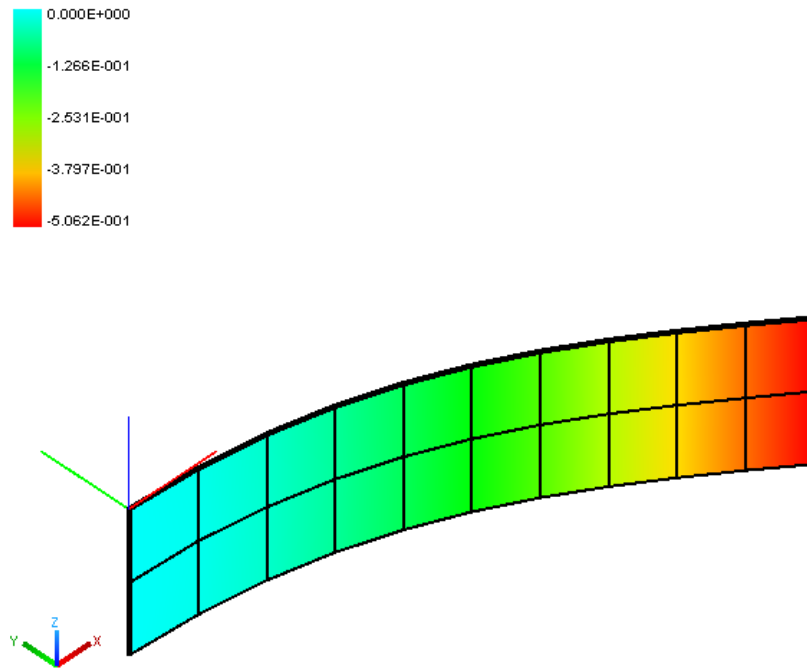

- Comparison with hand Calculations (see tutorial two):
 - o Displacement in y direction
 - Hand Calculation: 0.77160mm
 - NextFEM designer: 0.6250mm
 - Percent difference 19%
 - o Displacement in z direction:
 - Hand Calculation: -0.5556mm
 - NextFEM designer: -0.5062mm
 - Percent difference: 9%

Note that the difference is due to the choice of the mesh size.

Tutorial Four

The fourth tutorial consists in a cantilever beam loaded with distributed loads in directions x, y and z. The output of NextFEM Designer (Frame forces and displacement) is compared with hand calculations.

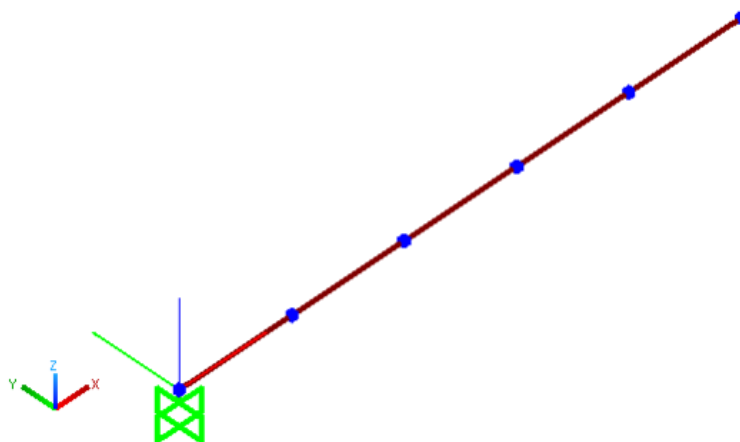

 Only flexural deformations are considered.

- Units: N for forces and mm for lengths.
- Material Properties:
 - o Name: Concrete;
 - o $E=30000 \text{ N/mm}^2$;
 - o $\nu=0.3$
 - o $F_k=25 \text{ N/mm}$
 - o $\text{Weight}=2.5e-5 \text{ N/mm}^3$;
 - o $\text{Mass}=2.55e-9 \text{ N/mm}^2/\text{g}$
- Section properties:
 - o $B=300 \text{ mm}$ (y direction);
 - o $H=500\text{mm}$ (z direction);
- Geometric properties:
 - o $L=5000 \text{ mm}$;
- Loads properties:
 - o $q_y=1 \text{ N/mm}$;
 - o $q_z=-1 \text{ N/mm}$;
 - o $q_x=-1 \text{ N/mm}$.

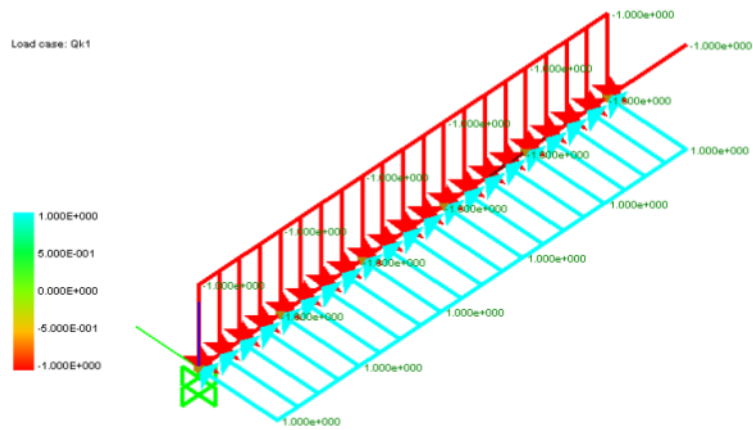

- NextFEM Designer's Results:
 - o Displacement in x direction: Node 6=-0.00278mm

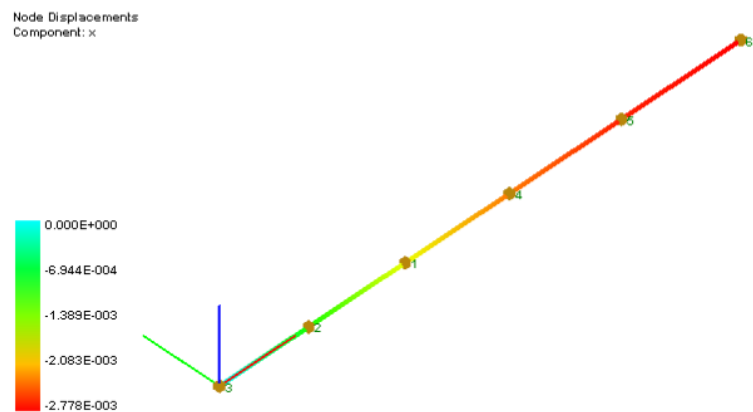

- o Displacement in y direction: Node 6=2.315mm

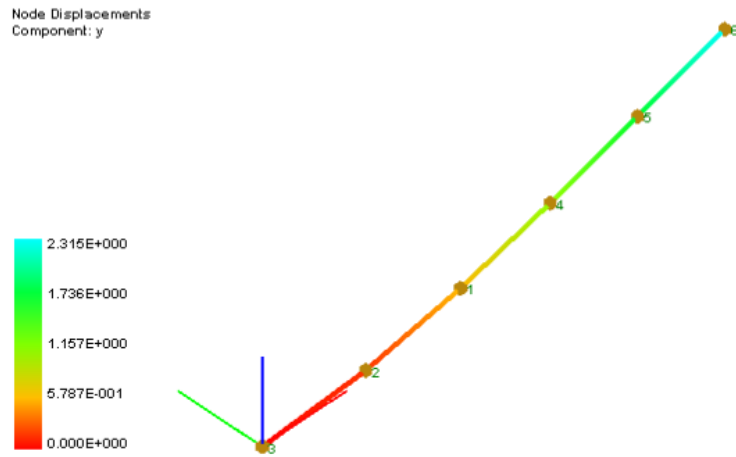

- o Displacement in z direction: Node 6=-0.8333mm

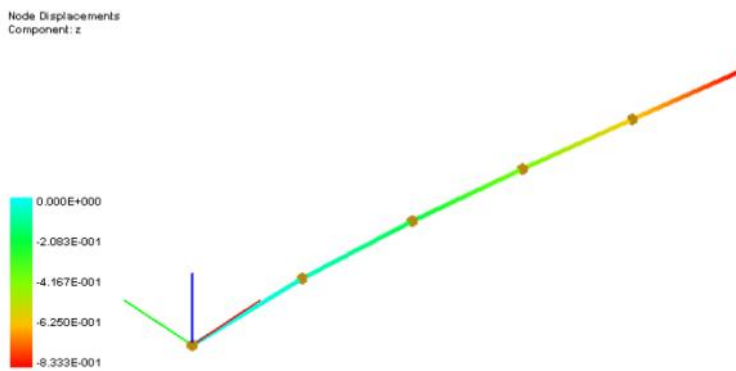

- o Moment Diagram: Values from *Results>Extract Data*
 - Mzz max: node 1: 125000000000 Nmm

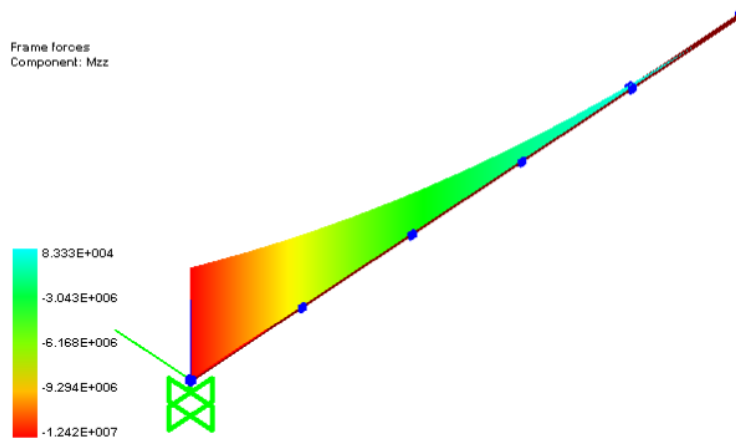

- Myy max: node 1: 125000000000 Nmm

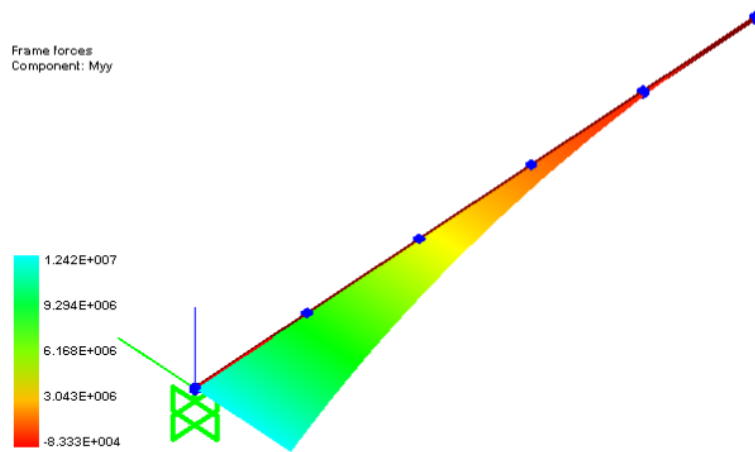

- Shear Diagram:
 - Vy

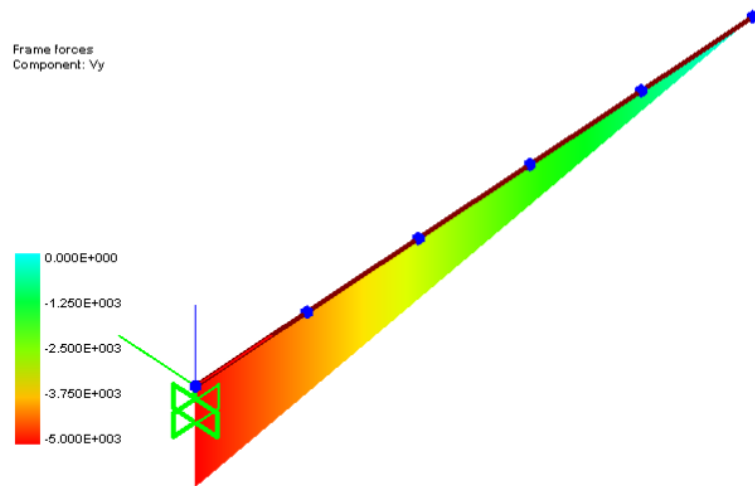

- Vz

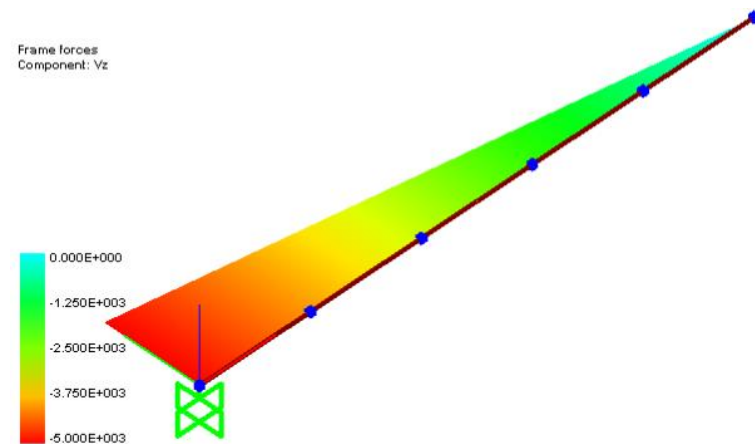

- Hand Calculations:
 - Moment diagram:
 - Mzz

$$M_{\max} = \frac{q_z l^2}{2} = 125000000000 \text{ Nmm} ;$$

- Myy

$$M_{\max} = \frac{q_y l^2}{2} = 125000000000 \text{ Nmm};$$

- Shear Diagram:

- Vy

$$V_{\max} = q_z l = 5000 \text{ N};$$

- Vz

$$V_{\max} = q_y l = 5000 \text{ N};$$

- Axial force diagram:

$$N_{\max} = q_x l = 5000 \text{ N};$$

- Max Displacement in x direction: Node 6

$$u_{6,x} = \frac{q_x l^2}{2EA} = 0.00278 \text{ mm}$$

- Max Displacement in y direction: Node 6

$$u_{6,y} = \frac{q_y l^4}{8EJ_y} = 2.315 \text{ mm}$$

- Max Displacement in z direction: Node 6

$$u_{6,z} = \frac{q_z l^4}{8EJ_z} = -0.8333 \text{ mm}$$

Tutorial Five

The fifth tutorial consists in a modal analysis of a 3D wooden frame-building . The output of NextFEM Designer (modes of vibration) is compared with the output of SAP2000®.

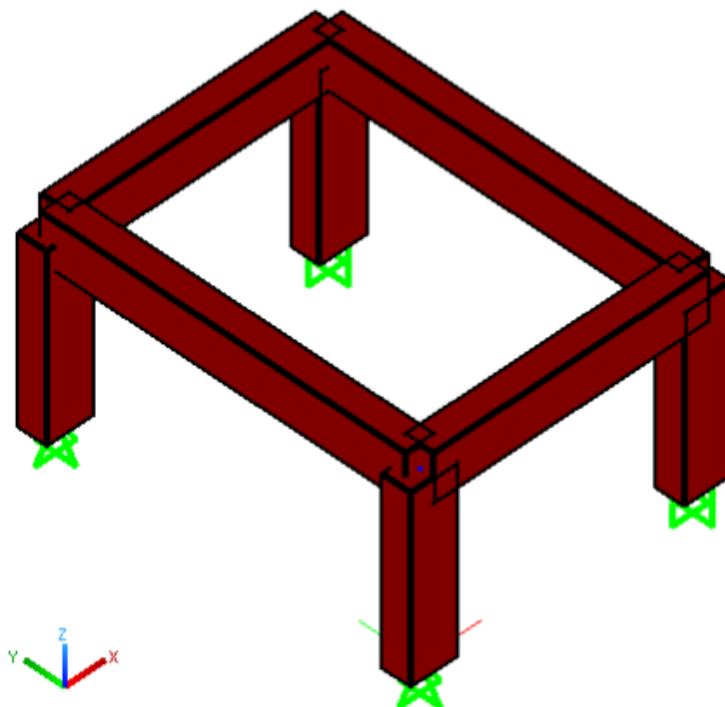

⚠️ Only flexural deformations are considered.

- Units: kN for forces and m for lengths.
- Material Properties:
 - o Name: GL24H;
 - o $E=9.40e+6$ kN/m²;
 - o $\nu=0.3$
 - o Weight=3.8 kN/m³;
 - o Mass=0 kN/m³/g
- Section properties:
 - o B=300 mm (y direction);
 - o H=500 mm (z direction);
- Geometric properties:
 - o $L_x=3$ m;
 - o $L_y=4$ m;
 - o $L_z=2$ m;
- Mass properties: at every nodes of the 1st storey
 - o $m_y=2.5$ kN/g;
 - o $m_z=-2.5$ kN/g;
 - o $m_x=-2.5$ kN/g

- NextFEM Designer's Results:

- o First mode:

Period:
1.481E-001s
Frequency:
6.750E+000s

Node Displacements
Component: xyz

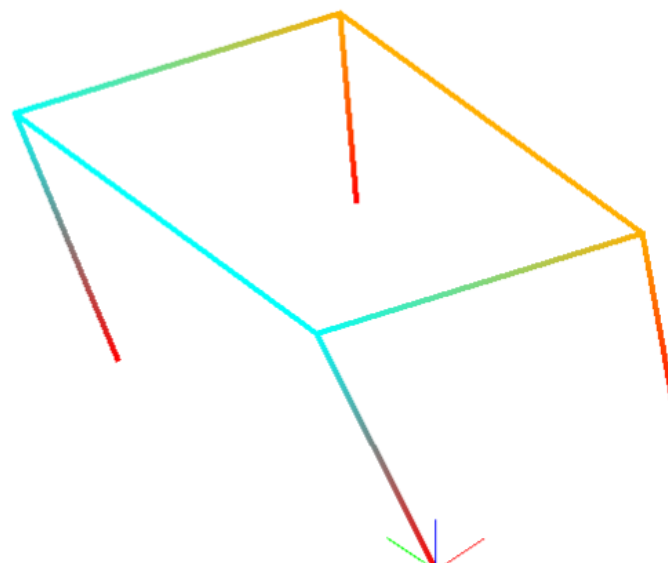
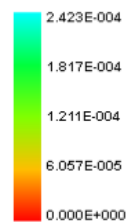

- o Second mode:

Period:
8.376E-002s
Frequency:
1.194E+001s

Node Displacements
Component: xyz

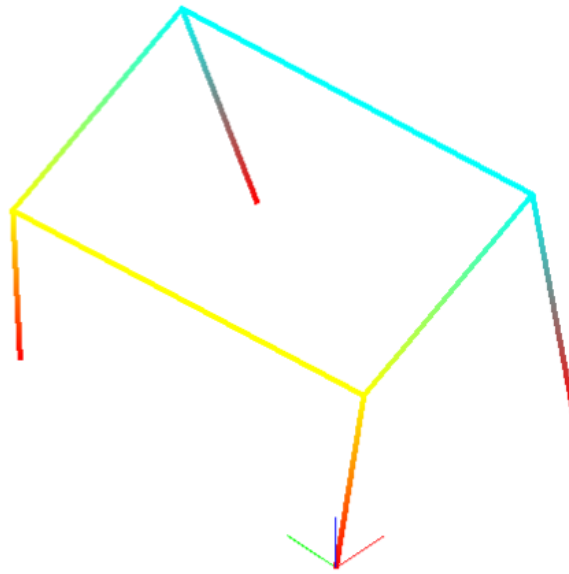
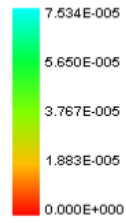

o Third mode:

Period:
7.794E-002s
Frequency:
1.283E+001s

Node Displacements
Component: xyz

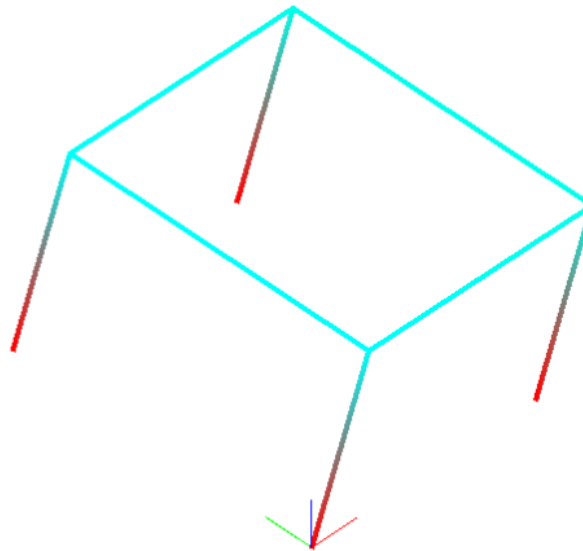
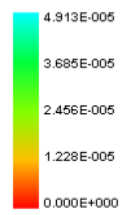

- SAP2000® results:

o First mode:

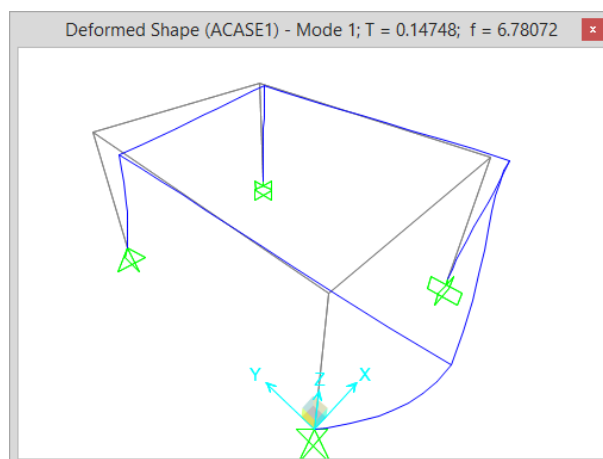

- o Second mode:

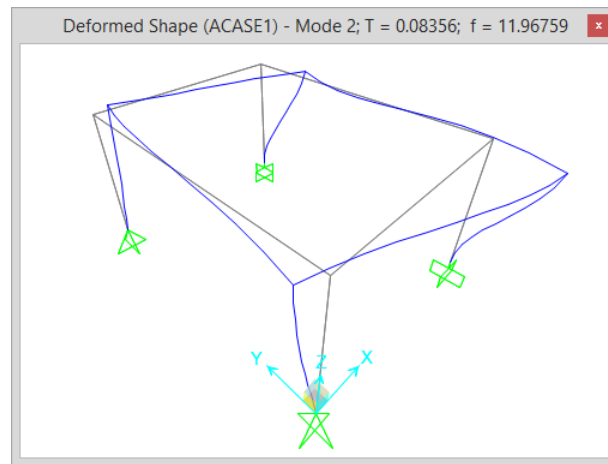

- o Third mode:

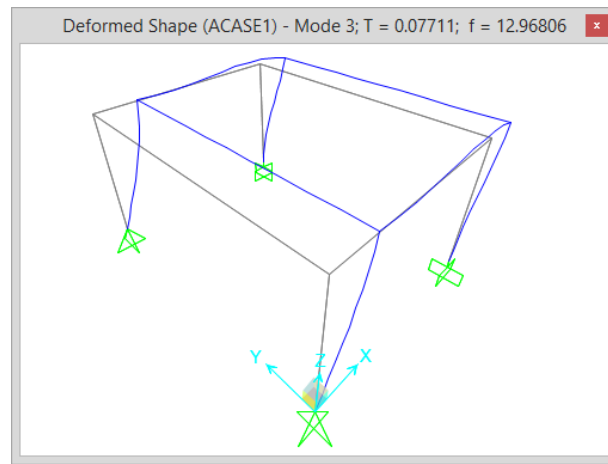

The test model, calculated with two different programs, shows the same results.

Tutorial Six

The sixth tutorial consists in a buckling analysis of a simply supported concrete column. The output of NextFEM Designer (i.e. the eigenvalues representing the load multipliers) is compared with the results computed by the Eulerian instability theory. The column is meshed into 5 elements of equal length.

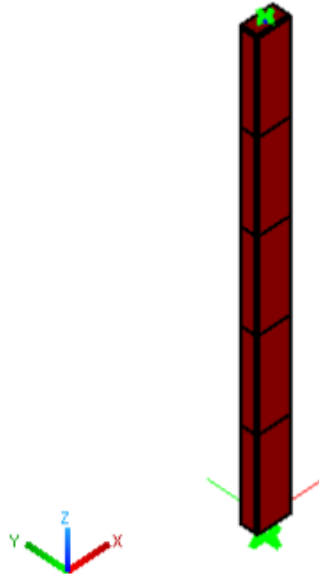

⚠ Only flexural deformations are considered.

- Units: kN for forces and m for lengths.
- Material Properties:
 - o Name: C25/30;
 - o $E=3.15e+6$ kN/m²;
 - o $\nu=0.2$
 - o Weight =25 kN/m³;
 - o Mass =2.5 kN/m³/g
- Section properties:
 - o B=100 mm (z);
 - o H=200 mm (y);
- Geometric properties:
 - o Ltot=3.0 m;
- Loads:
 - o Qz=-1 kN;

- NextFEM Designer's results:
 - o First mode:

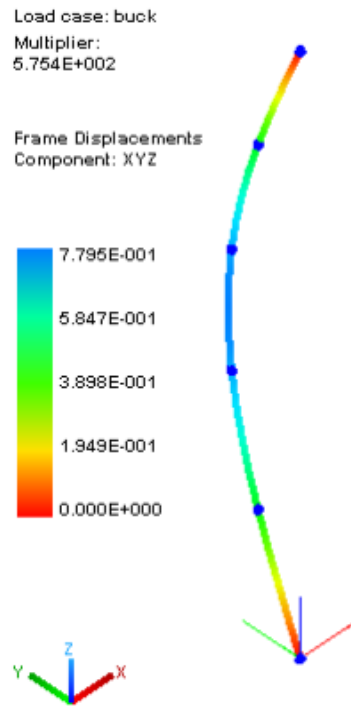

o Second mode:

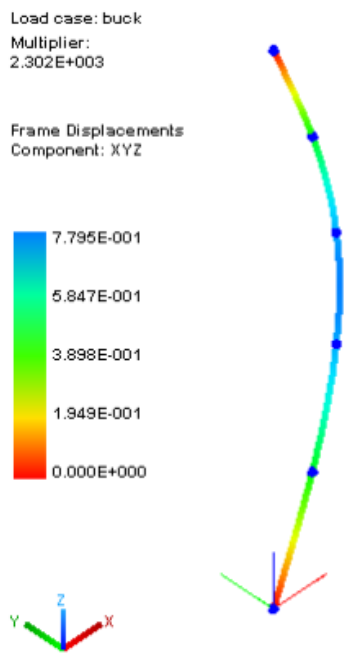

o Third mode:

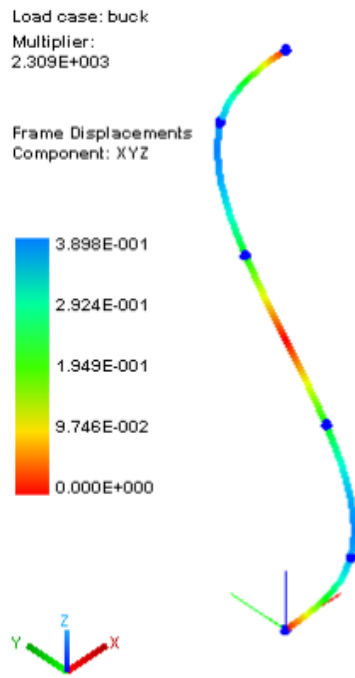

o Fourth mode:

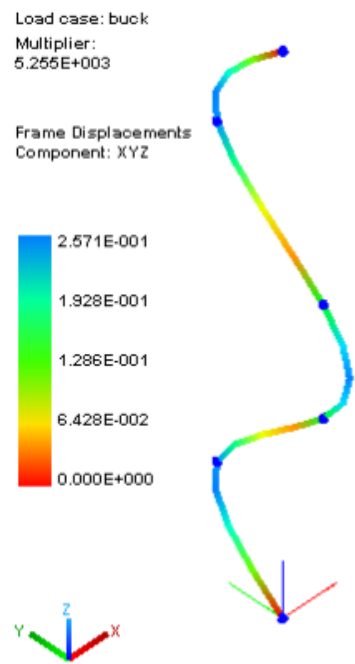

o Fifth mode:

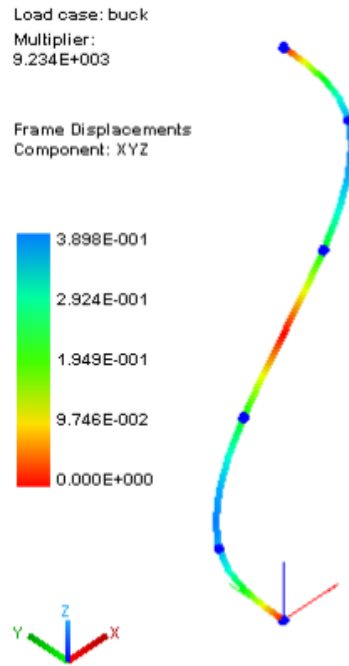

- Manual calculation:

- o The critical load is computed as come $P_{cr} = \pi^2 \frac{EJ}{(l/n)^2}$ with $n = 1, 2, 3, \dots$, and the inertia J of the direction of inflection.
- o Section inertia:

$$J_{yy} = \frac{1}{12} hb^3 = 16.7 \cdot 10^6 \text{ mm}^4$$

$$J_{zz} = \frac{1}{12} bh^3 = 66.7 \cdot 10^6 \text{ mm}^4$$

- o Theoretical results:

Bending around yy	Bending around zz
$\pi^2 \frac{EJ_{yy}}{l^2} = 575 \text{ kN}, \lambda = 575$	$\pi^2 \frac{EJ_{zz}}{l^2} = 2301 \text{ kN}, \lambda = 2301$
$\pi^2 \frac{EJ_{yy}}{(l/2)^2} = 2301 \text{ kN}, \lambda = 2301$	$\pi^2 \frac{EJ_{zz}}{(l/2)^2} = 9206 \text{ kN}, \lambda = 9206$
$\pi^2 \frac{EJ_{yy}}{(l/3)^2} = 5178 \text{ kN}, \lambda = 5178$	

NextFEM Designer's results are in agreement with the theoretical results.

Chapter 3

Verifications for steel scaffolds

In this chapter, all the verifications performed by *NextFEM Designer* for steel beams/trusses are described. Such verification are focused on scaffolds as per EN 12811-1.

Symbols

- A: Area
- J_z : Moment of inertia around x-axis
- J_y : Moment of inertia around y-axis
- J_{min} : Minimum moment of inertia
- J_t : Torsional Inertia
- D: Diameter of circular cross sections
- D_i : Inner diameter of pipe cross sections
- t_e : Thickness of pipe cross sections
- b: Base for any other cross sections
- h: Height for any other cross sections
- t_w : web thickness
- t_{f1} : thickness of bottom flange
- t_{f2} : thickness of upper flange
- t: thickness for planar sections
- N: Axial force
- V_y : Shear force along y direction
- V_z : Shear force along z direction
- M_t : Twisting moment
- M_{yy} : Moment around y local axis
- M_{zz} : Moment around z local axis
- E_m : material Young modulus
- G_m : material shear modulus
- ν_m : **material Poisson's ratio**
- f_k : material characteristic strength
- W_{elZ} : section modulus for Z axis
- W_{elY} : section modulus for Y axis
- W_{plZ} : plastic section modulus for Z axis
- W_{plY} : plastic section modulus for Y axis
- i_z : radius of inertia for Z axis
- i_y : radius of inertia for Y axis
- i_{min} : minimum radius of inertia
- SecType: 1=beam, 2=planar, 0=unknown
- SecBeamType: 0=unknown, 1=rectangular, 2=circular, 3=Cshape, 4=Tshape, 5=DoubleTshape, 6=Lspahe, 7=box, 8=pipe

- dx: axial relative displacement along beam axis
- dy: transversal deflection in local direction y
- dz: transversal deflection in local direction z.

Verification listing

Verifications performed by *NextFEM Designer* for steel beams/trusses are described afterwards. Each of them is expressed in terms of usage ratios of the checked section/element:

$$\rho = \frac{E_d}{R_d} = \frac{E_d}{\frac{R_k}{\gamma_M}}$$

with E_d design force

R_d is the design strength, equal to $\frac{R_k}{\gamma_M}$

R_k is the material characteristic strength

γ_M is the partial safety factor the material.

 WARNING: all the verifications listed do not support Class 4 transversal sections.

Estimation of section class

Conservatively, each section class is estimated as the maximum section class amongst the ones related to each part of the section, considered as fully in compression.

Section type	Parte	Ratio	Class 1	Class 2	Class 3
Rectangular		/			<i>always</i>
Double T, T, C	web	0.9(h-tf1)/tw	33ε	38ε	42ε
	flange	0.9(b/2-tw)/tf1	9ε	10ε	14ε
Angular	web	h _{max} /te			15ε
	flange	(b+h)/(2te)			11.5ε
Box	web	(h-2te)/te	9ε	10ε	14ε
	flange	(b-2te)/te	9ε	10ε	14ε
Pipe		D/te	50ε ²	70ε ²	90ε ²
Bar		/		<i>always</i>	
Generic		/			<i>always</i>

with $\varepsilon = \sqrt{\frac{235}{f_y}}$

The column name of the program output is reported between brackets (i.e. (*EulerBuckling*))

Tension/compression (Axial)

In tension:

$$\rho_N = \frac{N}{N_{Rd}} = \frac{N}{\frac{Af_{yk}}{\gamma_{M0}}}$$

In compression (Eulerian buckling):

$$\rho_{Nb} = \frac{N}{N_{b,Rd}} = \frac{N}{\frac{\chi_{\min} Af_{yk}}{\gamma_{M1}}}$$

with χ_{\min} calculated on the base of the following buckling coefficients, determined for rolled sections only:

Section type	α_y	α_z	α_{LT}
Rectangular	0.49	0.49	0.76
Double T, I	da 0.21 a 0.76	da 0.21 a 0.76	da 0.34 a 0.49
Angular, C, T	0.49	0.49	0.76
Box	0.49	0.49	0.76
Pipe	0.49	0.49	0.76
Bar	0.49	0.49	0.76
Generic	-	-	-

Shear (Shear)

$$\rho_V = \frac{V}{V_{Rd}} = \frac{V}{\frac{Af_{yk}}{\gamma_{M0} \sqrt{3}}}$$

Bending with shear interaction (Bending)

$$\rho_{Mrid} = \frac{M}{\alpha_{PL} \cdot W \cdot f_{yk} \cdot \cos(\rho_N)} = \frac{M}{M_{Rd} \cdot \cos(\rho_N)}$$

if the shear force does not exceed the 30% of plastic strength;

$$\rho_{Mrid} = \frac{M}{M_{Rd,red}}, \text{ with } M_{Rd,red} = M_{Rd} \left(1 - \min\left((2\rho_V - 1)^2, 1\right)\right)$$

if the shear force exceeds the 50% of plastic strength, $M_{Rd,red} = M_{Rd}$ otherwise.

Biaxial bending and axial load (TensBending_biAx and BuckBending_biAx)

If the element is compressed:

$$\rho_{MNb} = \frac{\rho_N}{\chi_{\min}} + \frac{\rho_{M_y}}{r_{ridN_{cr}}} + \frac{\rho_{M_z}}{r_{ridN_{cr}}} \text{ with } r_{ridN_{cr}} = 1 - \frac{\rho_N \bar{\lambda}^2}{\gamma_{M0}}$$

If the element is in tension:

$$\rho_{MNb} = \rho_N + \rho_{M_y} + \rho_{M_z}$$

Torsional buckling (TorsionBuckling)

⚠ WARNING: this checks is not performed for pipe sections in a scaffolding.

$$\rho_{MTb} = \frac{M}{M_{b,Rd}} = \frac{M}{\frac{\chi_{LT} A \cdot W_{pl} \cdot f_k}{\gamma_{M1}}}$$

For torsional buckling, the second-order twisting moment (Vlasov's contribution) is always neglected:

$$M_{cr} = \psi \frac{\pi}{L_0} \sqrt{EI_y \cdot GI_T} \sqrt{1 + \left(\frac{\pi}{L_0}\right)^2 \cdot \frac{EI_\omega}{GI_T}} \quad \text{con } I_\omega = 0$$

except for the following sections:

- double T, I: $I_\omega = \frac{(h-t_f)^2}{4} I_y$
- C-shaped: $I_\omega = \frac{(h-t_f)^2 \cdot b^3 \cdot t_f}{12} \cdot \frac{2F+3}{F+6}$ with $F = \frac{h-t_f}{b}$.

In evaluating the critical resisting moment, the coefficient ψ is forced to the value 1.127 if the beam has null moments at both ends. In any case, it is limited to 1.285.

Combined torsional buckling (TorsionBuck_comb)

$$\rho_{MNb} = \frac{\rho_N}{\chi_{\min}} + \frac{\rho_{M_y}}{\chi_{LT} \cdot r_{ridN_{cr}}} + \frac{\rho_{M_z}}{r_{ridN_{cr}}} \quad \text{and} \quad \rho_{MNb} = \frac{\rho_N}{\chi_{\min}} + \frac{\rho_{M_y}}{r_{ridN_{cr}}} + \frac{\rho_{M_z}}{\chi_{LT} \cdot r_{ridN_{cr}}} \quad (\text{for rotated sections})$$

Deflection checks

Deflection checks (Deflection)

$$\rho_f = \frac{\sqrt{f_y^2 + f_z^2}}{\frac{L}{100}}$$

⚠ WARNING: the code EN 12811-1 expects to check that the total deflection is less than 25mm. To satisfy such condition, the ratio ρ_f is calculated as the maximum value between the :

$$\frac{\sqrt{f_y^2 + f_z^2}}{25mm}$$

⚠ WARNING: this check is not performed for columns or standards.

Joint checks

Verifications on “joint elements” in the model are performed with:

$$\rho_{Sj} = \frac{F_{s1} + F_{s2}}{2F_{sd}} + \frac{F_p}{F_{pd}} + \frac{M_B}{2M_{Bd}}$$

with $F_{sd} = \frac{F_{sk}}{\gamma_{M0}}$ the joint strength, set by the user with Fsk

$F_{pd} = \frac{F_{pk}}{\gamma_{M0}}$ the joint pull-apart strength, set by the user with Fpk

$M_{Bd} = \frac{M_{Bk}}{\gamma_{M0}}$ the joint cruciform resisting moment, set by the user with MBx

$F_{s1} + F_{s2} = \sqrt{V_y^2 + V_z^2}$ and $F_p = N$ if $N > 0$ (tension).

Conservatively, the bending moment M_B is calculated as: $M_B = \sqrt{M_y^2 + M_z^2 + M_T^2}$ to represent both the flexure in clamps and the cruciform bending moment in right-angle couplers. To exclude a mechanism, set the corresponding strength to 0.

Verifications on “joint-nodes” in the model are performed in the same way but with:

$$F_{s1} + F_{s2} = \sqrt{V_y^2 + N^2} \text{ and } F_p = N$$

Conservatively, the bending moment M_B is calculated as: $M_B = \sqrt{M_y^2 + M_z^2 + M_T^2}$ to represent both the flexure in clamps and the cruciform bending moment in right-angle couplers. To exclude a mechanism, set the corresponding strength to 0.

Appendix 1 – Checking example

Steel properties

Steel code: $S = 355$

$$f_u := \begin{cases} (360\text{MPa}) & \text{if } S = 235 \\ (430\text{MPa}) & \text{if } S = 275 \\ (510\text{MPa}) & \text{if } S = 355 \end{cases} = 510\text{MPa}$$

$$f_y := \begin{cases} (235\text{MPa}) & \text{if } S = 235 \\ (275\text{MPa}) & \text{if } S = 275 \\ (355\text{MPa}) & \text{if } S = 355 \end{cases} = 355\text{MPa}$$

Partial safety factors:

$$\begin{aligned} \gamma_{M0} &:= 1.1 & \gamma_{Mb} &:= 1.35 & (\text{bolts}) \\ \gamma_{M1} &:= 1.1 & \gamma_{Ms_ult} &:= 1.25 & (\text{sliding}) \\ \gamma_{M2} &:= 1.25 & \gamma_{Mwca} &:= 1.35 & (\text{fillet welding}) \\ & & \gamma_{Mw1} &:= 1.05 & (\text{class 1 weldings}) \\ & & \gamma_{Mw2} &:= 1.2 & (\text{class 2 weldings}) \end{aligned}$$

Gamma_M0=1.1
Gamma_M1=1.1
Gamma_M2=1.25

Steel design strength:

$$f_d := \frac{f_y}{\gamma_{M0}} = 322.727\text{MPa}$$

Elastic modulus:

$$E_m := 210000\text{MPa}$$

Poisson's ratio:

$$\nu_m := 0.3$$

Shear modulus:

$$G_m := \frac{E_m}{2 \cdot (1 + \nu_m)} = 80769\text{MPa}$$

Steel weight density:

$$\rho_m := 7850 \frac{\text{kg}}{\text{m}^3}$$

MatID=1
fk=354999.951425536
Em=209999959.687168
Nlm=0.300000009519104
Gm=80768994.0631552
MatType=1
ftk=510
g_m=1.05
ServiceC=0
ServType=0

Section properties

Pipe 48.3x2.3mm $L := 1.91\text{m}$

$$t_e := 2.3\text{mm} \quad d_e := 48.3\text{mm} \quad d_i := d_e - 2 \cdot t_e = 43.7\text{mm}$$

$$A := \frac{\pi}{4} (d_e^2 - d_i^2) = 3.324 \times 10^{-4} \text{m}^2 \quad \text{per} := \pi \cdot d_e = 0.152\text{m}$$

$$I_{yy} := \frac{\pi}{4} \left[\left(\frac{d_e}{2} \right)^4 - \left(\frac{d_i}{2} \right)^4 \right] = 8.813 \times 10^{-8} \text{m}^4 \quad I_{zz} := I_{yy}$$

$$I_T := 2 \cdot I_{yy} = 1.763 \times 10^{-7} \text{m}^4$$

$$W_{ely} := \frac{I_{yy}}{\frac{d_e}{2}} = 3.649 \times 10^{-6} \text{m}^3 \quad W_{elz} := \frac{I_{zz}}{\frac{d_e}{2}} = 3.649 \times 10^{-6} \text{m}^3$$

$$W_{ply} := \frac{1}{6} (d_e^3 - d_i^3) = 4.871 \times 10^{-6} \text{m}^3 \quad W_{plz} := W_{ply}$$

$$i_z := \sqrt{\frac{I_{zz}}{A}} = 0.016\text{m} \quad i_y := \sqrt{\frac{I_{yy}}{A}} = 0.016\text{m}$$

$$i_{\min} := \min(i_z, i_y) = 0.016\text{m}$$

$$\epsilon := \sqrt{\frac{235}{\frac{f_y}{\text{MPa}}}} = 0.814$$

D=0.0483000043175936
Di=0.0437000037466112
te=0.00230000162766848
per=0.15171187020336667295744
A=0.000332143511207936

Jz=0.00000008800874528768
Jy=0.0000000880086580461568
Jt=0.000000176269031374848
Jmin=0.0000000880086580461568
WelZ=0.00000364425357819904
WelY=0.00000364424988721152
WplZ=0.0000048708603346944
Wply=0.0000048708603346944
iz=0.0162779612839936
iy=0.0162779545731072
imin=0.0162779545731072
SecType=1
SecBeamType=8
SectID=2

$$\text{Class} := \begin{cases} 1 & \text{if } \frac{d_e}{t_e} \leq 50 \cdot \epsilon^2 \\ \text{otherwise} & \end{cases} = 1 \quad \alpha_{pl} := \min\left(1.25, \frac{W_{ply}}{W_{ely}}\right) = 1.25$$

SectClass=1

Shear areas: $A_{vy} := 2 \cdot \frac{A}{\pi} = 2.116 \times 10^{-4} \text{ m}^2$ $A_{vz} := 2 \cdot \frac{A}{\pi}$

Buckling data: $L0 := 1.91 \text{ m} \leq 90 \cdot \frac{d_e}{t_e} \Rightarrow \alpha_y = 0.49$ $\alpha_{LT} = 0.76$

Design forces: Combination: ULS1

$N := -6.0608 \text{ kN}$ $M_t := 0.0011 \text{ kN}\cdot\text{m}$
 $V_y := 0.03395 \text{ kN}$ $M_{yy} := 0.0695 \text{ kN}\cdot\text{m}$
 $V_z := -0.079 \text{ kN}$ $M_{zz} := 0.0208 \text{ kN}\cdot\text{m}$
 $M_{yI} := 0.0695 \text{ kN}\cdot\text{m}$ $M_{zI} := 0.0208 \text{ kN}\cdot\text{m}$
 $M_{yJ} := -0.0815 \text{ kN}\cdot\text{m}$ $M_{zJ} := -0.02982 \text{ kN}\cdot\text{m}$

L0=1.91000014225408
 Avz=0.00021145
 Avy=0.00021145
 alphay=0.49
 alphaz=0.49
 alphaLT=0.76

N=-6.0608
 Vy=0.03395
 Vz=-0.079
 Mt=0.0011
 Myy=0.0695
 Mzz=0.0208

Deflections as per local axes:

$dx := -0.000165 \text{ m}$ $dy := 0.000215 \text{ m}$ $dz := 0.001825 \text{ m}$

MyI=0.0695
 MzI=0.0208
 MyJ=-0.0815
 MzJ=-0.02982
 rMyIJ=-0.8527654141384379766804472394
 rMzIJ=-0.696836425704292655772667979

Tension / compression

$N_{pId} := f_y \cdot \frac{A}{\gamma_{M0}} = 107.268 \text{ kN}$ $\rho_N := \frac{|N|}{N_{pId}} = 0.057$

Combined shear

$V_{Rd} := \sqrt{V_y^2 + V_z^2} = 0.086 \text{ kN}$ $V_{Rd} := \frac{A_{vy} \cdot f_y}{\sqrt{3} \cdot \gamma_{M0}} = 39.427 \text{ kN}$
 $\rho_V := \frac{V_{yz}}{V_{Rd}} = 2.181 \times 10^{-3}$

dx=-0.000165
 dy=0.000215
 dz=0.001825

NRd=107.19175485920386545137841245
 rN=0.0565419516465213973935335099
 @Axiat=0.0565419516465213973935335099

Bending

$M_{Rd} := \frac{\alpha_{pl} \cdot W_{ely} \cdot f_y}{\gamma_{M0}} = 1.472 \text{ kN}\cdot\text{m}$ $M_{yz} := \sqrt{M_{yy}^2 + M_{zz}^2} = 0.073 \text{ kN}\cdot\text{m}$

VRdy=39.398612334859818835365305306
 rVyz=0.0021828030808295912220727947
 @Shear=0.0021828030808295912220727947

$\rho_{pl03} := \begin{cases} \text{"simplified check"} & \text{if } \rho_V \leq 0.3 \\ \text{"complete check"} & \text{otherwise} \end{cases} = \text{"simplified check"}$

$\rho_{simplIM} := \frac{M_{yz}}{M_{Rd} \cdot \cos(\rho_N)} = 0.049$

W=0.0000364424988721152
 alphaPL=1.25
 Mplk=1.6171356661782558082999517184
 Mpld=1.4701233328893234620908651985
 MrdY=1.4701233328893234620908651985
 MrdZ=1.4701233328893234620908651985
 Myz=0.0725039066382336
 Mpl=1.4643288342528
 rM=0.0495134050100365716171254159
 @Bending=0.0495134050100365716171254155

Shear

$V_{Rdy} := \frac{A_{vy} \cdot f_y}{\sqrt{3} \cdot \gamma_{M0}} = 39.427 \text{ kN}$ $\rho_{Vy} := \frac{|V_y|}{V_{Rdy}} = 8.611 \times 10^{-4}$
 $V_{Rdz} := \frac{A_{vz} \cdot f_y}{\sqrt{3} \cdot \gamma_{M0}} = 39.427 \text{ kN}$ $\rho_{Vz} := \frac{|V_z|}{V_{Rdz}} = 2.004 \times 10^{-3}$

Bending-shear interaction

$\rho_{MVy} := \begin{cases} \min\left[2 \cdot \rho_{Vy} - 1, 1\right] & \text{if } \rho_{Vy} > 0.5 \\ 0 & \text{otherwise} \end{cases} = 0$ $f_{yRy} := \max\left[1 - \rho_{MVy}, 0\right] \cdot f_y = 355 \text{ MPa}$
 $\rho_{MVz} := \begin{cases} \min\left[2 \cdot \rho_{Vz} - 1, 1\right] & \text{if } \rho_{Vz} > 0.5 \\ 0 & \text{otherwise} \end{cases} = 0$ $f_{yRz} := \max\left[1 - \rho_{MVz}, 0\right] \cdot f_y = 355 \text{ MPa}$

VRdy=39.398612334859818835365305306
 rVyz=0.0021828030808295912220727947
 VRdz=39.398612334859818835365305306
 rVz=0.0020055141132288494673979674
 rV=0.0020055141132288494673979674
 @Shear=0.0020055141132288494673979674

$$M_{rdY} := M_{Rd} \frac{f_y R_y}{f_y} = 1.472 \text{ kN}\cdot\text{m}$$

$$M_{rdZ} := M_{Rd} \frac{f_y R_z}{f_y} = 1.472 \text{ kN}\cdot\text{m}$$

$$\rho_{Myy} := \frac{|M_{yy}|}{M_{rdY}} = 0.047$$

$$\rho_{Mzz} := \frac{|M_{zz}|}{M_{rdZ}} = 0.014$$

Simplified compression/bending check

$$\rho_{MN} := \rho_N + \rho_{Myy} + \rho_{Mzz} = 0.118$$

Axial buckling

$$\lambda_1 := \pi \sqrt{\frac{E_m}{f_y}} = 76.409 \quad \lambda_{aZ} := \frac{L_0}{i_z} = 1.535 \quad \lambda_z := \frac{L_0}{i_z} = 117.295$$

$$\varphi_z := \frac{1}{2} [1 + \alpha_z (\lambda_{aZ} - 0.2) + \lambda_{aZ}^2] = 2.005 \quad \chi_z := \frac{1}{\varphi_z + \sqrt{\varphi_z^2 - \lambda_{aZ}^2}} = 0.303$$

$$N_{bRdz} := \frac{\chi_z \cdot A \cdot f_y}{\gamma_{M1}} = 32.548 \text{ kN}$$

$$\rho_{NEz} := \frac{|N|}{N_{bRdz}} = 0.186$$

Y axis:

$$\lambda_{aY} := \frac{L_0}{i_y} = 1.535 \quad \lambda_y := \frac{L_0}{i_z} = 117.295$$

$$\varphi_y := \frac{1}{2} [1 + \alpha_y (\lambda_{aY} - 0.2) + \lambda_{aY}^2] = 2.005$$

$$\chi_y := \frac{1}{\varphi_y + \sqrt{\varphi_y^2 - \lambda_{aY}^2}} = 0.303$$

$$N_{bRdy} := \frac{\chi_y \cdot A \cdot f_y}{\gamma_{M1}} = 32.548 \text{ kN}$$

$$\rho_{NEy} := \frac{|N|}{N_{bRdy}} = 0.18621$$

Combined axial buckling check

$$\chi_{\min} := \min(\chi_y, \chi_z) = 0.303$$

$$N_{cr} := \frac{\pi^2 \cdot E_m \cdot A}{\lambda_z^2} = 50.072 \text{ kN}$$

$$\rho_{Ncry} := \begin{cases} 1 - \frac{N}{N_{cr}} & \text{if } N \leq 0 \\ 1 & \text{otherwise} \end{cases} = 1.121 \quad \rho_{Ncrz} := \begin{cases} 1 - \frac{N \cdot \lambda_{aZ}^2}{\gamma_{M0} \cdot N_{cr}} & \text{if } N \leq 0 \\ 1 & \text{otherwise} \end{cases} = 0.879$$

$$\rho_{MNb_semp1} := \frac{\rho_N}{\chi_{\min}} \frac{\gamma_{M1}}{\gamma_{M0}} + \frac{\rho_{Myy}}{\rho_{Ncry}} \frac{\gamma_{M1}}{\gamma_{M0}} + \frac{\rho_{Mzz}}{\rho_{Ncrz}} \frac{\gamma_{M1}}{\gamma_{M0}} = 0.244 \quad \text{C4.2.32}$$

ELASTIC CHECK: for pipe sections
only

$$r_e := \frac{d_e}{2} = 24.15 \text{ mm} \quad r_i := \frac{d_i}{2} = 21.85 \text{ mm}$$

$$\sigma_n := \frac{N}{A} - \frac{M_{yy}}{W_{ely}} + \frac{M_{zz}}{W_{elz}} = -31.579 \text{ MPa}$$

$$\tau_{\max} := \frac{2 \cdot r_e \cdot M_t}{\pi \cdot (r_e^4 - r_i^4)} + \frac{4 \cdot V_{yz}}{3 \cdot A} \frac{(r_e^2 + r_e \cdot r_i + r_i^2)}{(r_e^2 + r_i^2)} = 0.667 \text{ MPa}$$

$$\sigma_{id} := \sqrt{\sigma_n^2 + 3 \tau_{\max}^2} = 31.6 \text{ MPa}$$

$$\rho_{id} := \frac{\sigma_{id}}{f_y} = 0.098$$

Torsional stability check for general steel members

NOTE: second order torsional contribution is always neglected.

$$\beta_{LT} := 1 \quad \lambda_{LT0} := 0.2$$

$$\begin{aligned} \psi_{CL} &= -0.897196452549140159939968945 \\ \text{Eps} &= 0.813616525737984 \\ \text{flim} &= 0.0250000030302208 \end{aligned}$$

$$\begin{aligned} V_{yz} &= 0.085999405236224 \\ \text{Fsk} &= 15.0000004759552 \\ \text{Fpk} &= 30.0000009519104 \\ \text{MBx} &= 0.800000003014656 \end{aligned}$$

$$\begin{aligned} \lambda_{bcl1} &= 76.409143437973796214953476096 \\ \lambda_{bclAdimz} &= 1.5356351954015641080277912517 \end{aligned}$$

$$\begin{aligned} \phi_{iz} &= 2.00631830708224 \\ \chi_{iz} &= 0.3032604869983414317755489643 \end{aligned}$$

$$\begin{aligned} N_{bRdz} &= 32.507023780808995830534864999 \\ \rho_{NEz} &= 0.1864468141107701649076616236 \end{aligned}$$

$$\begin{aligned} \lambda_{bclAdimy} &= 1.5356358284954397481138061191 \\ \phi_{iy} &= 2.00631948148736 \\ \chi_{iy} &= 0.3032602787003787379926746472 \\ N_{bRdy} &= 32.507001452984841086968965466 \\ \rho_{NEy} &= 0.1864469421740025026657545038 \end{aligned}$$

$$\begin{aligned} \rho_{Ne} &= 0.1864469421740025026657545038 \\ @\text{EulerBuckling} &= 0.1864469421740025026657545038 \end{aligned}$$

$$\begin{aligned} \chi_{imin} &= 0.3032602787003787379926746472 \\ \text{redNcry} &= 0.878785473806336 \\ \text{redNcrz} &= 0.878785608024064 \\ \rho_{MNb_semplicata} &= 0.2458936831647663570537406675 \\ @\text{BuckBending_biax} &= 0.2458936831647663570537406675 \end{aligned}$$

$$\begin{aligned} J_w &= 0 \\ S_n &= -31606.232302629741956156611185 \\ r_e &= 0.0241500021587968 \end{aligned}$$

$$M_{BAy} := \begin{cases} -\psi_y & \text{if } |M_{yJ}| < |M_{yI}| \\ -1 & \text{otherwise} \end{cases} = 0.853$$

$$\psi_y := \frac{M_{yJ}}{M_{yI}} = -1.173$$

$$I_w := 0$$

ri=0.0218500018733056
TauMax=663.302266945536

Sid=31618.9217652736
roID=0.0979741371854708722442710053
@_Sigmaid=0.097974137185470872244271005

$$\psi_{Ty} := 1.75 - 1.05 \cdot M_{BAy} + 0.3 \cdot M_{BAy}^2 = 1.073 \quad \text{C4.2.31}$$

$$M_{crY} := \frac{\psi_{Ty} \cdot \pi}{L0} \cdot \sqrt{E_m \cdot I_{zz} \cdot G_m \cdot I_T} \cdot \sqrt{1 + \left(\frac{\pi}{L0}\right)^2 \cdot \frac{E_m \cdot I_w}{G_m \cdot I_T}} = 28.643 \text{ kN}\cdot\text{m} \quad \text{C4.2.30}$$

$$\lambda_{LTy} := \sqrt{\frac{W_{ply} \cdot f_y}{M_{crY}}} = 0.246$$

$$\varphi_{LTy} := 0.5 \cdot \left[1 + \alpha_{LT} \cdot (\lambda_{LTy} - \lambda_{LT0}) + \beta_{LT} \cdot \lambda_{LTy}^2 \right] = 0.548$$

$$k_{cy} := \begin{cases} 1 & \text{if } \psi_y = 1 \\ \text{otherwise} \\ \frac{1}{1.33 - 0.33 \cdot \psi_y} & \text{if } \psi_y < 1 \wedge \psi_y \geq -1 \\ 0.94 & \text{otherwise} \end{cases} = 0.94$$

betaLT=1

lambdaLT0=0.2

psiY=-1.1726551249506386420361108475

MBAy=0.8527656415965381723754051919

psiTy=1.07275876302848

McrY=28.622274734914192988226987340

$$f_{ty} := 1 - 0.5 \cdot (1 - k_{cy}) \cdot \left[1 - 2 \cdot (\lambda_{LTy} - 0.8)^2 \right] = 0.988 \quad \text{4.2.53}$$

$$\chi_{LTy} := \min \left[1, \frac{1}{\lambda_{LTy}^2 \cdot f_{ty}}, \frac{1}{f_{ty} \cdot (\varphi_{LTy} + \sqrt{\varphi_{LTy}^2 - \beta_{LT} \cdot \lambda_{LTy}^2})} \right] = 0.976 \quad \text{4.2.51}$$

lambdaLTy=0.245790408704

$$M_{bRdy} := \frac{\chi_{LTy} \cdot W_{ply} \cdot f_y}{\gamma_{M1}} = 1.534 \text{ kN}\cdot\text{m} \quad \text{4.2.50}$$

phiLTy=0.54760682029056

kcY=0.94

$$\rho_{MbRdy} := \frac{|M_{yy}|}{M_{bRdy}} = 0.04531 \quad \text{4.2.49}$$

$$\psi_z := \frac{M_{zJ}}{M_{zI}} = -1.434$$

$$M_{BAz} := \begin{cases} -\psi_z & \text{if } |M_{zJ}| < |M_{zI}| \\ -1 & \text{otherwise} \end{cases} = 0.698$$

fty=0.988428942442496

$$\psi_{Tz} := 1.75 - 1.05 \cdot M_{BAz} + 0.3 \cdot M_{BAz}^2 = 1.164 \quad \text{C4.2.31}$$

chiLTy=0.9756526208655689509338037528

$$M_{crz} := \frac{\psi_{Tz} \cdot \pi}{L0} \cdot \sqrt{E_m \cdot I_{yy} \cdot G_m \cdot I_T} \cdot \sqrt{1 + \left(\frac{\pi}{L0}\right)^2 \cdot \frac{E_m \cdot I_w}{G_m \cdot I_T}} = 31.067 \text{ kN}\cdot\text{m} \quad \text{C4.2.30}$$

MbRdy=1.5336862960456021156266142187

roFTy=0.045291029274346618564415259

$$\lambda_{LTz} := \sqrt{\frac{W_{plz} \cdot f_y}{M_{crz}}} = 0.236$$

$$\varphi_{LTz} := 0.5 \cdot \left[1 + \alpha_{LT} \cdot (\lambda_{LTz} - \lambda_{LT0}) + \beta_{LT} \cdot \lambda_{LTz}^2 \right] = 0.541$$

psiZ=-1.4350570135441755713986665158

MBAz=0.696836425704292655772667979

$$k_{cz} := \begin{cases} 1 & \text{if } \psi_z = 1 \\ \text{otherwise} \\ \frac{1}{1.33 - 0.33 \cdot \psi_z} & \text{if } \psi_z < 1 \wedge \psi_z \geq -1 \\ 0.94 & \text{otherwise} \end{cases} = 0.94$$

psiTz=1.16399594799104

McrZ=31.056561063623696200580648598

$$f_{tz} := 1 - 0.5 \cdot (1 - k_{cz}) \cdot \left[1 - 2 \cdot (\lambda_{LTz} - 0.8)^2 \right] = 0.989 \quad \text{4.2.53}$$

$$\chi_{LTz} := \min \left[1, \frac{1}{\lambda_{LTz}^2 \cdot f_{tz}}, \frac{1}{f_{tz} \cdot \left(\varphi_{LTz} + \sqrt{\varphi_{LTz}^2 - \beta_{LT} \cdot \lambda_{LTz}^2} \right)} \right] = 0.983 \quad 4.2.51$$

lambdaLIZ=0.23596105728

phiLTz=0.541504040861696

$$M_{bRdz} := \frac{\chi_{LTz} \cdot W_{plz} \cdot f_y}{\gamma_{M1}} = 1.545 \text{ kN}\cdot\text{m} \quad 4.2.50$$

kcZ=0.94

$$\rho_{MbRdz} := \frac{|M_{zz}|}{M_{bRdz}} = 0.01347 \quad 4.2.49$$

$$\rho_{MbRd} := \max(\rho_{MbRdz}, \rho_{MbRdy}) = 0.045$$

$$M_{Ay} := \begin{cases} -M_{yI} & \text{if } |M_{yI}| > |M_{yJ}| \\ M_{yJ} & \text{otherwise} \end{cases} = -0.082 \text{ kN}\cdot\text{m}$$

ftz=0.989088421249024

$$M_{By} := \begin{cases} M_{yJ} & \text{if } |M_{yI}| > |M_{yJ}| \\ -M_{yI} & \text{otherwise} \end{cases} = -0.07 \text{ kN}\cdot\text{m}$$

chiLTz=0.9826395572317815134462442436

$$M_{yEqEd} := \max(|0.6 \cdot M_{Ay} - 0.4 \cdot M_{By}|, |0.4 \cdot M_{By}|) = 0.0278 \text{ kN}\cdot\text{m} \quad C4.2.35$$

MbRdz=1.5446694762544516176728628594

$$\rho_{NFty} := \frac{\rho_N \cdot \gamma_{M1}}{\chi_{min} \cdot \gamma_{M0}} + \frac{M_{yEqEd}}{M_{bRdy}} \cdot \frac{1}{\rho_{Ncry}} + \frac{\rho_{Mzz} \cdot \gamma_{M1}}{\rho_{Ncrz} \cdot \gamma_{M0}} = 0.218 \quad C4.2.36$$

roFTz=0.0134528136958361892255342507

@TorsionBuckling=0.0452910292743466185644

$$M_{Az} := \begin{cases} -M_{zI} & \text{if } |M_{zI}| > |M_{zJ}| \\ M_{zJ} & \text{otherwise} \end{cases} = -0.03 \text{ kN}\cdot\text{m}$$

MaY=-0.0814552358846464

MbY=-0.0694622309318656

$$M_{Bz} := \begin{cases} M_{zJ} & \text{if } |M_{zI}| > |M_{zJ}| \\ -M_{zI} & \text{otherwise} \end{cases} = -0.021 \text{ kN}\cdot\text{m}$$

MyeqEd=0.03258209435385856

$$M_{zEqEd} := \max(|0.6 \cdot M_{Az} - 0.4 \cdot M_{Bz}|, |0.4 \cdot M_{Bz}|) = 0.00957 \text{ kN}\cdot\text{m} \quad C4.2.35$$

roNFty=0.2243103707116388153051998723

$$\rho_{NFtz} := \frac{\rho_N \cdot \gamma_{M1}}{\chi_{min} \cdot \gamma_{M0}} + \frac{\rho_{Myy} \cdot \gamma_{M1}}{\rho_{Ncry} \cdot \gamma_{M0}} + \frac{M_{zEqEd}}{M_{bRdz}} \cdot \frac{1}{\rho_{Ncrz}} = 0.235 \quad C4.2.36$$

Slenderness limit $s_L := \frac{L_0}{200 \cdot i_{min}} = 0.586$

MaZ=-0.0298207028445184

MbZ=-0.020780150685696

Deflections

$$d_{tot} := \sqrt{dy^2 + dz^2} = 1.838 \text{ mm} \quad \rho_{def} := \max \left(\frac{d_{tot}}{L}, \frac{d_{tot}}{25 \text{ mm}} \right) = 0.096$$

MzeqEd=0.01192828113780736

roNFtz=0.2409922346361507476401954453

roNFT=0.2409922346361507476401954453

@TorsionBuck_comb=0.24099223463615

@_SlendLimit=0.586830914399989198567738327

defl=0.00183748582703104

roDef=0.0962034392763205512623843953

Chapter 4

Verifications for aluminium scaffolds

In this chapter, all the verifications performed by *NextFEM Designer* for aluminium beams/trusses are described. Such verification is performed on scaffolds as per EN 12811-1 and contains references to EN 1999-1-1 (Eurocode 9).

Symbols

- A: Area
- J_z : Moment of inertia around x-axis
- J_y : Moment of inertia around y-axis
- J_{min} : Minimum moment of inertia
- J_t : Torsional Inertia
- D: Diameter of circular cross sections
- D_i : Inner diameter of pipe cross sections
- t_e : Thickness of pipe cross sections
- b: Base for any other cross sections
- h: Height for any other cross sections
- t_w : web thickness
- t_{f1} : thickness of bottom flange
- t_{f2} : thickness of upper flange
- t: thickness for planar sections
- N: Axial force
- V_y : Shear force along y direction
- V_z : Shear force along z direction
- M_t : Twisting moment
- M_{yy} : Moment around y local axis
- M_{zz} : Moment around z local axis
- E_m : material Young modulus
- G_m : material shear modulus
- ν_m : **material Poisson's ratio**
- f_k : material characteristic strength
- W_{elZ} : section modulus for Z axis
- W_{elY} : section modulus for Y axis
- W_{plZ} : plastic section modulus for Z axis
- W_{plY} : plastic section modulus for Y axis
- i_z : radius of inertia for Z axis
- i_y : radius of inertia for Y axis
- i_{min} : minimum radius of inertia
- SecType: 1=beam, 2=planar, 0=unknown
- SecBeamType: 0=unknown, 1=rectangular, 2=circular, 3=Cshape, 4=Tshape, 5=DoubleTshape, 6=Lspahe, 7=box, 8=pipe

- dx: axial relative displacement along beam axis
- dy: transversal deflection in local direction y
- dz: transversal deflection in local direction z.

Verification listing

Verifications performed by *NextFEM Designer* for aluminium beams/trusses are described afterwards. Each of them is expressed in terms of usage ratios of the checked section/element:

$$\rho = \frac{E_d}{R_d} = \frac{E_d}{\frac{R_k}{\gamma_M}}$$

with E_d design force

R_d is the design strength, equal to $\frac{R_k}{\gamma_M}$

R_k is the material characteristic strength

γ_M is the partial safety factor the material.

 WARNING: all the verifications listed do not support Class 4 transversal sections.

 WARNING: Inside the program, the material library *Alloy* lists the most spread aluminium alloys. Pay attention to the material names, which may include some limitations for particular section shapes:

SH - Sheet (EN 485)

ST - Strip (EN 485)

PL - Plate (EN 485)

ET - Extruded Tube (EN 755)

EP - Extruded Profiles (EN 755)

ER/B - Extruded Rod and Bar (EN 755)

DT - Drawn Tube (EN 754)

FO - Forgings (EN 586)

Estimation of section class

Conservatively, each section class is estimated as the maximum section class amongst the ones related to each part of the section, considered as fully in compression (t_e signifies section thickness).

Section type	Part	Ratio	Class 1	Class 2	Class 3
Rectangular		/			<i>always</i>
Double T, T, C	web	$0.9(h-tf1)/t_w$	β_1	β_2	β_3
	flange	$0.9(b/2-t_w)/t_{f1}$	β_1	β_2	β_3
Angular	web	h_{max}/t_e			β_3
	flange	$(b+h)/(2t_e)$			β_3
Box	web	$(h-2t_e)/t_e$	β_1	β_2	β_3
	flange	$(b-2t_e)/t_e$	β_1	β_2	β_3
Pipe		$3\sqrt{D/t_e}$	β_1	β_2	β_3
Bar		/		<i>always</i>	
Generic		/			<i>always</i>

The values β_1 , β_2 , β_3 are computed automatically by considering the ratios β/ϵ reported on the following table and multiplied by the parameter ϵ defined as follows:

$$\varepsilon = \sqrt{\frac{250}{f_0}}$$

For the flanges in a section, the coefficients for the outstand parts are used; for webs and sides of a section, the coefficients for the internal parts are employed.

The design codes provide different coefficients for welded and non-welded sections. Coefficients for non-welded sections are taken by default, but it is possible to enforce the variable *welded=1* before to start the checking, to force the procedure to assume all the sections as welded. To force the checking for welded material ONLY at beam ends, set the variable *weldedEnds=1*.

⚠ WARNING: for the welded section checking, the verification procedure uses the value of *f0HAZ* from the *Alloy material library*. In the case a custom material is used, please add the line "*f0HAZ=xxx*" in the textbox inside the *Verification* mask, with *f0HAZ* in MPa.

	Durability class	Internal part			Outstand part		
		$\beta_{1/\varepsilon}$	$\beta_{2/\varepsilon}$	$\beta_{3/\varepsilon}$	$\beta_{1/\varepsilon}$	$\beta_{2/\varepsilon}$	$\beta_{3/\varepsilon}$
w/o welds	A	11	16	22	3	4.5	6
	B	13	16.5	18	3.5	4.5	5
with welds	A	9	13	18	2.5	4	5
	B	10	13.5	15	3	3.5	4

The column name of the program output is reported between brackets (i.e. (*EulerBuckling*)). In the following formula, *f0* (or *f0HAZ*) is written as *fyk*.

Tension/compression (Axial)

In tension:

$$\rho_N = \frac{N}{N_{Rd}} = \frac{N}{\frac{A f_{yk}}{\gamma_{M0}}}$$

In compression:

$$\rho_{Nb} = \frac{N}{N_{b,Rd}} = \frac{N}{\frac{\chi_{\min} A f_{yk}}{\gamma_{M1}}}$$

with χ_{\min} calculated on the base of the buckling coefficients, determined from Table 6.5 in Eurocode 9. The *k* parameter is always taken as 1.

Shear (Shear)

$$\rho_V = \frac{V}{V_{Rd}} = \frac{V}{\frac{A f_{yk}}{\gamma_{M0} \sqrt{3}}}$$

Bending with shear interaction (Bending)

$\rho_{Mrid} = \frac{M}{\alpha_{PL} \cdot W \cdot f_{yk} \cdot \cos(\rho_N)} = \frac{M}{M_{Rd} \cdot \cos(\rho_N)}$ if the shear force does not exceed the 30% of plastic strength;

$\rho_{Mrid} = \frac{M}{M_{Rd,red}}$, with $M_{Rd,red} = M_{Rd} \left(1 - \min\left((2\rho_V - 1)^2, 1\right)\right)$ if the shear force exceeds the 50% of plastic strength, $M_{Rd,red} = M_{Rd}$ otherwise.

Biaxial bending and axial load (BuckBending_biAx and TensBending_biAx)

If the element is compressed:

$$\rho_{MNb} = \frac{\rho_N}{\chi_{min}} + \frac{\rho_{M_y}}{r_{ridN_{cr}}} + \frac{\rho_{M_z}}{r_{ridN_{cr}}} \text{ with } r_{ridN_{cr}} = 1 - \frac{\rho_N \bar{\lambda}^2}{\gamma_{M0}}$$

If the element is in tension:

$$\rho_{MNb} = \rho_N + \rho_{M_y} + \rho_{M_z}$$

Torsional buckling (TorsionBuckling)

⚠ WARNING: this checks is not performed for pipe sections in a scaffolding.

$$\rho_{MTb} = \frac{M}{M_{b,Rd}} = \frac{M}{\frac{\chi_{LT} A \cdot W_{pl} \cdot f_k}{\gamma_{M1}}}$$

For torsional buckling, the second-order twisting moment (Vlasov's contribution) is always neglected:

$$M_{cr} = \psi \frac{\pi}{L_0} \sqrt{EI_y \cdot GI_T} \sqrt{1 + \left(\frac{\pi}{L_0}\right)^2 \cdot \frac{EI_\omega}{GI_T}} \quad \text{con } I_\omega = 0$$

except for the following sections:

- double T, I: $I_\omega = \frac{(h - t_f)^2}{4} I_y$
- C-shaped: $I_\omega = \frac{(h - t_f)^2 \cdot b^3 \cdot t_f}{12} \cdot \frac{2F + 3}{F + 6}$ with $F = \frac{h - t_f}{b}$.

In evaluating the critical resisting moment, the coefficient ψ is forced to the value 1.127 if the beam has null moments at both ends. In any case, it is limited to 1.285. The values for the proper instability curves are taken from 6.3.2.2 of Eurocode 9.

Combined torsional buckling (TorsionBuck_comb)

$$\rho_{MNB} = \frac{\rho_N}{\chi_{\min}} + \frac{\rho_{M_y}}{\chi_{LT} \cdot r_{ridN_{cr}}} + \frac{\rho_{M_z}}{r_{ridN_{cr}}} \quad \text{and} \quad \rho_{MNB} = \frac{\rho_N}{\chi_{\min}} + \frac{\rho_{M_y}}{r_{ridN_{cr}}} + \frac{\rho_{M_z}}{\chi_{LT} \cdot r_{ridN_{cr}}} \quad (\text{for rotated sections})$$

Deflection checks

Deflection checks (Deflection)

$$\rho_f = \frac{\sqrt{f_y^2 + f_z^2}}{\frac{L}{100}}$$

⚠ WARNING: the code EN 12811-1 expects to check that the total deflection is less than 25mm. To satisfy such condition, the ratio ρ_f is calculated as the maximum value between the :

$$\frac{\sqrt{f_y^2 + f_z^2}}{25mm}$$

⚠ WARNING: this check is not performed for columns or standards.

Joint checks

Verifications on "joint elements" in the model are performed with:

$$\rho_{Sj} = \frac{F_{s1} + F_{s2}}{2F_{sd}} + \frac{F_p}{F_{pd}} + \frac{M_B}{2M_{Bd}}$$

with $F_{sd} = \frac{F_{sk}}{\gamma_{M0}}$ the joint strength, set by the user with Fsk

$F_{pd} = \frac{F_{pk}}{\gamma_{M0}}$ the joint pull-apart strength, set by the user with Fpk

$M_{Bd} = \frac{M_{Bk}}{\gamma_{M0}}$ the joint cruciform resisting moment, set by the user with MBx

$F_{s1} + F_{s2} = \sqrt{V_y^2 + V_z^2}$ and $F_p = N$ if $N > 0$ (tension).

Conservatively, the bending moment M_B is calculated as: $M_B = \sqrt{M_y^2 + M_z^2 + M_T^2}$ to represent both the flexure in clamps and the cruciform bending moment in right-angle couplers.
To exclude a mechanism, set the corresponding strength to 0.

Verifications on "joint-nodes" in the model are performed in the same way but with:

$$F_{s1} + F_{s2} = \sqrt{V_y^2 + N^2} \quad \text{and} \quad F_p = N$$

Conservatively, the bending moment M_B is calculated as: $M_B = \sqrt{M_y^2 + M_z^2 + M_T^2}$ to represent both the flexure in clamps and the cruciform bending moment in right-angle couplers. To exclude a mechanism, set the corresponding strength to 0.

Appendix 2 – Checking example

Data for alloy

Classification from EN 755-2

Partial safety factors:

$$\gamma_{M0} := 1.1$$

$$\gamma_{M1} := 1.1$$

$$\gamma_{M2} := 1.25$$

Design strength for $t < 5$:

$$f_o := 250 \text{ MPa} \quad f_u := 290 \text{ MPa}$$

Elastic modulus:

$$E_m := 70000 \text{ MPa}$$

Poisson's ratio:

$$\nu_m := 0.3$$

Shear modulus:

$$G_m := \frac{E_m}{2 \cdot (1 + \nu_m)} = 26923 \text{ MPa}$$

Density:

$$\rho_m := 2700 \frac{\text{kg}}{\text{m}^3}$$

Section properties

Pipe 48.3x2.3mm

$$t_e := 2.3 \text{ mm} \quad d_e := 48.3 \text{ mm} \quad d_i := d_e - 2 \cdot t_e = 43.7 \text{ mm}$$

$$A := \frac{\pi}{4} \cdot (d_e^2 - d_i^2) = 3.324 \times 10^{-4} \cdot \text{m}^2$$

$$I_{yy} := \frac{\pi}{4} \cdot \left[\left(\frac{d_e}{2} \right)^4 - \left(\frac{d_i}{2} \right)^4 \right] = 8.813 \times 10^{-8} \text{ m}^4 \quad I_{zz} := I_{yy}$$

$$I_T := 2 \cdot I_{yy} = 1.763 \times 10^{-7} \text{ m}^4$$

$$W_{ely} := \frac{I_{yy}}{\frac{d_e}{2}} = 3.649 \times 10^{-6} \cdot \text{m}^3 \quad W_{elz} := \frac{I_{zz}}{\frac{d_e}{2}} = 3.649 \times 10^{-6} \cdot \text{m}^3$$

$$W_{ply} := \frac{1}{6} \cdot (d_e^3 - d_i^3) = 4.871 \times 10^{-6} \cdot \text{m}^3 \quad W_{plz} := W_{ply}$$

$$i_z := \sqrt{\frac{I_{zz}}{A}} = 16.284 \text{ mm} \quad i_y := \sqrt{\frac{I_{yy}}{A}} = 16.284 \text{ mm}$$

$$\epsilon := \sqrt{\frac{250}{\frac{f_o}{\text{MPa}}}} = 1 \quad \beta_\epsilon := 3 \cdot \sqrt{\frac{d_e}{t_e}} = 13.748$$

$$\text{Class} := \begin{cases} 1 & \text{if } \beta_\epsilon \leq 13 \\ \text{otherwise} \\ 2 & \text{if } \beta_\epsilon \leq 16.5 \\ \text{otherwise} \\ 3 & \text{if } \beta_\epsilon \leq 18 \\ \text{otherwise} \\ 4 & \text{otherwise} \end{cases} = 2$$

$$\alpha_{pl} := \min \left(1.25, \frac{W_{ply}}{W_{ely}} \right) = 1.25$$

Shear areas: $A_{vy} := 2 \cdot \frac{A}{\pi} = 2.116 \times 10^{-4} \text{ m}^2$ $A_{vz} := 2 \cdot \frac{A}{\pi}$

Buckling data: $L_0 := 2.5 \text{ m}$ $\alpha_z := 0.2$ $\alpha_y := 0.2$ $\alpha_{LT} := 0.6$

Forces Combination: SLU1

$N := 0.05378 \text{ kN}$ $M_t := 0.04 \text{ kN}\cdot\text{m}$
 $V_y := -0.00466 \text{ kN}$ $M_{yy} := -0.07221 \text{ kN}\cdot\text{m}$
 $V_z := 0.06910 \text{ kN}$ $M_{zz} := 0.01081 \text{ kN}\cdot\text{m}$
 $M_{y1} := -0.07222 \text{ kN}\cdot\text{m}$ $M_{z1} := 0.01081 \text{ kN}\cdot\text{m}$
 $M_{yJ} := 0.07337 \text{ kN}\cdot\text{m}$ $M_{zJ} := -0.0195 \text{ kN}\cdot\text{m}$

$dx := -8.97329330651136 \text{ E-06 m}$ $dy := 0.00329626123501568 \text{ m}$ $dz := 0.000794948316168192 \text{ m}$

Compression / tension 6.17, 6.20 - EC9

$N_{p1d} := f_o \cdot \frac{A}{\gamma_{M0}} = 75.541 \text{ kN}$ $\rho_N := \frac{|N|}{N_{p1d}} = 7.119 \times 10^{-4}$

Combined shear 6.2.6 - EC9

$V_{yz} := \sqrt{V_y^2 + V_z^2} = 0.069 \text{ kN}$ $V_{Rd} := \frac{A_{vy} \cdot f_o}{\sqrt{3} \cdot \gamma_{M0}} = 27.765 \text{ kN}$
 $\rho_V := \frac{V_{yz}}{V_{Rd}} = 2.494 \times 10^{-3}$

Bending

$M_{Rd} := \frac{\alpha_{pl} \cdot W_{ely} \cdot f_o}{\gamma_{M0}} = 1.037 \text{ kN}\cdot\text{m}$ $M_{yz} := \sqrt{M_{yy}^2 + M_{zz}^2} = 0.073 \text{ kN}\cdot\text{m}$

$V_{pl03} := \begin{cases} \text{"simplified check"} & \text{if } \rho_V \leq 0.3 \\ \text{"COMPLETE check"} & \text{otherwise} \end{cases} = \text{"simplified check"}$

$\rho_{sempM} := \frac{M_{yz}}{M_{Rd} \cdot \cos(\rho_N)} = 0.07$

Shear strength

$V_{Rdy} := \frac{A_{vy} \cdot f_o}{\sqrt{3} \cdot \gamma_{M0}} = 27.765 \text{ kN}$ $\rho_{Vy} := \frac{|V_y|}{V_{Rdy}} = 1.678 \times 10^{-4}$

$V_{Rdz} := \frac{A_{vz} \cdot f_o}{\sqrt{3} \cdot \gamma_{M0}} = 27.765 \text{ kN}$ $\rho_{Vz} := \frac{|V_z|}{V_{Rdz}} = 2.489 \times 10^{-3}$

M-V interaction 6.2.8 - EC9

$\rho_{MVy} := \begin{cases} \min\left[2 \cdot \rho_{Vy} - 1, 1\right] & \text{if } \rho_{Vy} > 0.5 \\ 0 & \text{otherwise} \end{cases} = 0$ $f_{oRy} := \max\left[(1 - \rho_{MVy}) \cdot f_o, 0\right] = 250 \text{ MPa}$

$\rho_{MVz} := \begin{cases} \min\left[2 \cdot \rho_{Vz} - 1, 1\right] & \text{if } \rho_{Vz} > 0.5 \\ 0 & \text{otherwise} \end{cases} = 0$ $f_{oRz} := \max\left[(1 - \rho_{MVz}) \cdot f_o, 0\right] = 250 \text{ MPa}$

$M_{rdY} := M_{Rd} \cdot \frac{f_{oRy}}{f_o} = 1.037 \text{ kN}\cdot\text{m}$ $M_{rdZ} := M_{Rd} \cdot \frac{f_{oRz}}{f_o} = 1.037 \text{ kN}\cdot\text{m}$

$\rho_{Myy} := \frac{|M_{yy}|}{M_{rdY}} = 0.07$ $\rho_{Mzz} := \frac{|M_{zz}|}{M_{rdZ}} = 0.01$

Combined axial-bending strength

$$\rho_{MN} := \rho_N + \rho_{Myy} + \rho_{Mzz} = 0.081$$

Eulerian buckling

6.3.1 - EC9

$$\lambda_1 := \pi \cdot \sqrt{\frac{E_m}{f_o}} = 52.569 \quad \lambda_{aZ} := \frac{L_0}{i_z} = 2.92 \quad \lambda_z := \frac{L_0}{i_z} = 153.527$$

$$\varphi_z := \frac{1}{2} \left[1 + \alpha_z (\lambda_{aZ} - 0) + \lambda_{aZ}^2 \right] = 5.057 \quad \chi_z := \min \left(\frac{1}{\varphi_z + \sqrt{\varphi_z^2 - \lambda_{aZ}^2}}, 1 \right) = 0.109$$

$$\kappa := 1 \quad \omega_z := 1 \quad \omega_y := 1$$

$$N_{bRdz} := \frac{\kappa \cdot \chi_z \cdot \omega_z \cdot A \cdot f_o}{\gamma_{M1}} = 8.225 \text{ kN} \quad \rho_{NEz} := \frac{|N|}{N_{bRdz}} = 6.539 \times 10^{-3}$$

Y axis:

$$\lambda_{aY} := \frac{L_0}{i_y} = 2.92 \quad \lambda_y := \frac{L_0}{i_z} = 153.527$$

$$\varphi_y := \frac{1}{2} \left[1 + \alpha_y (\lambda_{aY} - 0.2) + \lambda_{aY}^2 \right] = 5.037$$

$$\chi_y := \min \left(\frac{1}{\varphi_y + \sqrt{\varphi_y^2 - \lambda_{aY}^2}}, 1 \right) = 0.109$$

$$N_{bRdy} := \frac{\kappa \cdot \chi_y \cdot \omega_y \cdot A \cdot f_o}{\gamma_{M1}} = 8.265 \text{ kN} \quad \rho_{NEy} := \frac{|N|}{N_{bRdy}} = 0.00651$$

Combined Euler buckling and bending

$$\chi_{\min} := \min(\chi_y, \chi_z) = 0.109 \quad N_{cr} := \frac{\pi^2 \cdot E_m \cdot A}{\lambda_z^2} = 9.742 \text{ kN}$$

$$\rho_{Ncry} := \begin{cases} 1 - \frac{\rho_N \cdot \lambda_{aY}^2}{\gamma_{M0}} & \text{if } N \leq 0 \\ 1 & \text{otherwise} \end{cases} \quad \rho_{Ncrz} := \begin{cases} 1 - \frac{\rho_N \cdot \lambda_{aZ}^2}{\gamma_{M0}} & \text{if } N \leq 0 \\ 1 & \text{otherwise} \end{cases}$$

$$\rho_{MNb_semp1} := \frac{\rho_N \cdot \gamma_{M1}}{\chi_{\min} \cdot \gamma_{M0}} + \frac{\rho_{Myy} \cdot \gamma_{M1}}{\rho_{Ncry} \cdot \gamma_{M0}} + \frac{\rho_{Mzz} \cdot \gamma_{M1}}{\rho_{Ncrz} \cdot \gamma_{M0}} = 0.087$$

ELASTIC CHECK only for pipes

$$r_e := \frac{d_e}{2} = 24.15 \text{ mm} \quad r_i := \frac{d_i}{2} = 21.85 \text{ mm}$$

$$\sigma_n := \frac{N}{A} - \frac{M_{yy}}{W_{ely}} + \frac{M_{zz}}{W_{elz}} = 22.91 \text{ MPa}$$

$$\tau_{\max} := \frac{2 \cdot r_e \cdot M_t}{\pi \cdot (r_e^4 - r_i^4)} + \frac{4 \cdot V_{yz} \cdot (r_e^2 + r_e \cdot r_i + r_i^2)}{3 \cdot A \cdot (r_e^2 + r_i^2)} = 5.896 \text{ MPa}$$

$$\sigma_{id} := \sqrt{\sigma_n^2 + 3 \tau_{\max}^2} = 25.084 \text{ MPa}$$

$$\rho_{id} := \frac{\sigma_{id}}{f_o} = 0.11$$

Torsional buckling

Warning: Vlasov's contribution is always neglected.

$$\lambda_{LT0} := 0.4$$

$$\psi_y := \frac{M_{yJ}}{M_{yI}} = -1.016$$

$$M_{BAy} := \begin{cases} -\psi_y & \text{if } |M_{yJ}| < |M_{yI}| \\ -1 & \text{otherwise} \end{cases} = 0.984$$

$$I_w := 0$$

$$\psi_{Ty} := \min(1.75 - 1.05 \cdot M_{BAy} + 0.3 \cdot M_{BAy}^2, 1.285) = 1.007$$

$$M_{crY} := \frac{\psi_{Ty} \cdot \pi}{L0} \cdot \sqrt{E_m \cdot I_{zz} \cdot G_m \cdot I_T} \cdot \sqrt{1 + \left(\frac{\pi}{L0}\right)^2 \cdot \frac{E_m \cdot I_w}{G_m \cdot I_T}} = 6.849 \text{ kN}\cdot\text{m}$$

$$\lambda_{LTy} := \sqrt{\frac{W_{ply} \cdot f_o}{M_{crY}}} = 0.422$$

$$\varphi_{LTy} := 0.5 \left[1 + \alpha_{LT} (\lambda_{LTy} - \lambda_{LT0}) + \lambda_{LTy}^2 \right] = 0.595$$

$$k_{cy} := \begin{cases} 1 & \text{if } \psi_y = 1 \\ \text{otherwise} \\ \frac{1}{1.33 - 0.33 \cdot \psi_y} & \text{if } \psi_y < 1 \wedge \psi_y \geq -1 \\ 0.94 & \text{otherwise} \end{cases} = 0.94$$

$$f_{ty} := 1 - 0.5(1 - k_{cy}) \left[1 - 2(\lambda_{LTy} - 0.8)^2 \right] = 0.979$$

$$\chi_{LTy} := \min \left[1, \frac{1}{\lambda_{LTy}^2 \cdot f_{ty}}, \frac{1}{f_{ty} \left(\varphi_{LTy} + \sqrt{\varphi_{LTy}^2 - \lambda_{LTy}^2} \right)} \right] = 1$$

$$M_{bRdy} := \frac{\chi_{LTy} \cdot W_{ply} \cdot f_o}{\gamma_{M1}} = 1.107 \text{ kN}\cdot\text{m}$$

$$\rho_{MbRdy} := \frac{|M_{yy}|}{M_{bRdy}} = 0.06523$$

$$\psi_z := \frac{M_{zI}}{M_{zI}} = -1.804$$

$$M_{BAz} := \begin{cases} -\psi_z & \text{if } |M_{zI}| < |M_{zI}| \\ \frac{-1}{\psi_z} & \text{otherwise} \end{cases} = 0.554$$

$$\psi_{Tz} := \min(1.75 - 1.05 \cdot M_{BAz} + 0.3 \cdot M_{BAz}^2, 1.285) = 1.26$$

$$M_{crz} := \frac{\psi_{Tz} \cdot \pi}{L0} \cdot \sqrt{E_m \cdot I_{yy} \cdot G_m \cdot I_T} \cdot \sqrt{1 + \left(\frac{\pi}{L0}\right)^2 \cdot \frac{E_m \cdot I_w}{G_m \cdot I_T}} = 8.568 \text{ kN}\cdot\text{m}$$

$$\lambda_{LTz} := \sqrt{\frac{W_{plz} \cdot f_o}{M_{crz}}} = 0.377$$

$$\varphi_{LTz} := 0.5 \left[1 + \alpha_{LT} (\lambda_{LTz} - \lambda_{LT0}) + \lambda_{LTz}^2 \right] = 0.564$$

$$k_{cz} := \begin{cases} 1 & \text{if } \psi_z = 1 \\ \text{otherwise} \\ \frac{1}{1.33 - 0.33 \cdot \psi_z} & \text{if } \psi_z < 1 \wedge \psi_z \geq -1 \\ 0.94 & \text{otherwise} \end{cases} = 0.94$$

$$f_{tz} := 1 - 0.5(1 - k_{cz}) \left[1 - 2(\lambda_{LTz} - 0.8)^2 \right] = 0.981$$

$$\chi_{LTz} := \min \left[1, \frac{1}{\lambda_{LTz}^2 \cdot f_{tz}}, \frac{1}{f_{tz} \left(\varphi_{LTz} + \sqrt{\varphi_{LTz}^2 - \lambda_{LTz}^2} \right)} \right] = 1$$

$$M_{bRdz} := \frac{\chi_{LTz} \cdot W_{plz} \cdot f_o}{\gamma_{M1}} = 1.107 \text{ kN}\cdot\text{m}$$

$$\rho_{MbRdz} := \frac{|M_{zz}|}{M_{bRdz}} = 0.00977$$

$$M_{crY} := \frac{\psi_{Ty} \cdot \pi}{L_0} \cdot \sqrt{E_m \cdot I_{zz} \cdot G_m \cdot I_T} \cdot \sqrt{1 + \left(\frac{\pi}{L_0}\right)^2 \cdot \frac{E_m \cdot I_w}{G_m \cdot I_T}} = 6.849 \text{ kN}\cdot\text{m}$$

$$\lambda_{LTy} := \sqrt{\frac{W_{ply} \cdot f_o}{M_{crY}}} = 0.422$$

$$\varphi_{LTy} := 0.5 \left[1 + \alpha_{LT} (\lambda_{LTy} - \lambda_{LT0}) + \lambda_{LTy}^2 \right] = 0.595$$

$$k_{cy} := \begin{cases} 1 & \text{if } \psi_y = 1 \\ \text{otherwise} \\ \frac{1}{1.33 - 0.33 \cdot \psi_y} & \text{if } \psi_y < 1 \wedge \psi_y \geq -1 \\ 0.94 & \text{otherwise} \end{cases} = 0.94$$

$$f_{ty} := 1 - 0.5(1 - k_{cy}) \left[1 - 2(\lambda_{LTy} - 0.8)^2 \right] = 0.979$$

$$\chi_{LTy} := \min \left[1, \frac{1}{\lambda_{LTy}^2 \cdot f_{ty}}, \frac{1}{f_{ty} \left(\varphi_{LTy} + \sqrt{\varphi_{LTy}^2 - \lambda_{LTy}^2} \right)} \right] = 1$$

$$M_{bRdy} := \frac{\chi_{LTy} \cdot W_{ply} \cdot f_o}{\gamma_{M1}} = 1.107 \text{ kN}\cdot\text{m}$$

$$\rho_{MbRdy} := \frac{|M_{yy}|}{M_{bRdy}} = 0.06523$$

$$\psi_z := \frac{M_{zI}}{M_{zI}} = -1.804$$

$$M_{BAz} := \begin{cases} -\psi_z & \text{if } |M_{zI}| < |M_{zI}| \\ \frac{-1}{\psi_z} & \text{otherwise} \end{cases} = 0.554$$

$$\psi_{Tz} := \min(1.75 - 1.05 \cdot M_{BAz} + 0.3 \cdot M_{BAz}^2, 1.285) = 1.26$$

$$M_{crz} := \frac{\psi_{Tz} \cdot \pi}{L_0} \cdot \sqrt{E_m \cdot I_{yy} \cdot G_m \cdot I_T} \cdot \sqrt{1 + \left(\frac{\pi}{L_0}\right)^2 \cdot \frac{E_m \cdot I_w}{G_m \cdot I_T}} = 8.568 \text{ kN}\cdot\text{m}$$

$$\lambda_{LTz} := \sqrt{\frac{W_{plz} \cdot f_o}{M_{crz}}} = 0.377$$

$$\varphi_{LTz} := 0.5 \left[1 + \alpha_{LT} (\lambda_{LTz} - \lambda_{LT0}) + \lambda_{LTz}^2 \right] = 0.564$$

$$k_{cz} := \begin{cases} 1 & \text{if } \psi_z = 1 \\ \text{otherwise} \\ \frac{1}{1.33 - 0.33 \cdot \psi_z} & \text{if } \psi_z < 1 \wedge \psi_z \geq -1 \\ 0.94 & \text{otherwise} \end{cases} = 0.94$$

$$f_{tz} := 1 - 0.5(1 - k_{cz}) \left[1 - 2(\lambda_{LTz} - 0.8)^2 \right] = 0.981$$

$$\chi_{LTz} := \min \left[1, \frac{1}{\lambda_{LTz}^2 \cdot f_{tz}}, \frac{1}{f_{tz} \left(\varphi_{LTz} + \sqrt{\varphi_{LTz}^2 - \lambda_{LTz}^2} \right)} \right] = 1$$

$$M_{bRdz} := \frac{\chi_{LTz} \cdot W_{plz} \cdot f_o}{\gamma_{M1}} = 1.107 \text{ kN}\cdot\text{m}$$

$$\rho_{MbRdz} := \frac{|M_{zz}|}{M_{bRdz}} = 0.00977$$

$$M_{Ay} := \begin{cases} -M_{yI} & \text{if } |M_{yI}| > |M_{yJ}| \\ M_{yJ} & \text{otherwise} \end{cases} = 0.073 \text{ kN}\cdot\text{m}$$

$$M_{By} := \begin{cases} M_{yJ} & \text{if } |M_{yI}| > |M_{yJ}| \\ -M_{yI} & \text{otherwise} \end{cases} = 0.072 \text{ kN}\cdot\text{m}$$

$$M_{yEqEd} := \max(|0.6 \cdot M_{Ay} - 0.4 \cdot M_{By}|, |0.4 \cdot M_{By}|) = 0.02888 \text{ kN}\cdot\text{m}$$

$$\rho_{NFTy} := \frac{\rho_N}{\chi_{\min}} \cdot \frac{\gamma_{M1}}{\gamma_{M0}} + \frac{M_{yEqEd}}{M_{bRdy}} \cdot \frac{1}{\rho_{Ncry}} + \frac{\rho_{Mzz}}{\rho_{Ncrz}} \cdot \frac{\gamma_{M1}}{\gamma_{M0}} = 0.043$$

$$M_{Az} := \begin{cases} -M_{zI} & \text{if } |M_{zI}| > |M_{zJ}| \\ M_{zJ} & \text{otherwise} \end{cases} = -0.02 \text{ kN}\cdot\text{m}$$

$$M_{Bz} := \begin{cases} M_{zJ} & \text{if } |M_{zI}| > |M_{zJ}| \\ -M_{zI} & \text{otherwise} \end{cases} = -0.011 \text{ kN}\cdot\text{m}$$

$$M_{zEqEd} := \max(|0.6 \cdot M_{Az} - 0.4 \cdot M_{Bz}|, |0.4 \cdot M_{Bz}|) = 0.00738 \text{ kN}\cdot\text{m}$$

$$\rho_{NFTz} := \frac{\rho_N}{\chi_{\min}} \cdot \frac{\gamma_{M1}}{\gamma_{M0}} + \frac{\rho_{Myy}}{\rho_{Ncry}} \cdot \frac{\gamma_{M1}}{\gamma_{M0}} + \frac{M_{zEqEd}}{M_{bRdz}} \cdot \frac{1}{\rho_{Ncrz}} = 0.083$$

Slenderness limit $s_L := \frac{L_0}{200 \cdot \min(i_z, i_y)} = 0.768$

Deflections $L := L_0$

$$d_{\text{tot}} := \sqrt{d_y^2 + d_z^2} = 3.391 \text{ mm} \quad \rho_{\text{def}} := \max\left(\frac{d_{\text{tot}}}{L}, \frac{d_{\text{tot}}}{25 \text{ mm}}\right) = 0.136$$