



NextFEM Designer
Validation of verifications

Version 2.5 and above

© NextFEM 2015-2026

Summary

Chapter 1 Introduction	5
Supported design codes	5
Chapter 2 Analysis validation	6
Types of analysis	6
Static analysis	6
Origin and features of the program	6
Reliability of the program	7
Tutorial One	7
Tutorial Two	17
Case a	17
Case b	23
Tutorial Three	28
Tutorial Four	30
Tutorial Five	34
Tutorial Six	38
Chapter 3 Verifications for steel members	42
Symbols	42
Verification listing	42
Estimation of section class	43
Tension/compression (Axial)	43
Shear (Shear)	44
Bending with shear interaction (Bending)	44
Biaxial bending and axial load (BuckBending_biax and TensBending_biax)	44
Torsional buckling (TorsionBuckling)	44
Combined torsional buckling (TorsionBuck_comb)	45
Deflection checks	45
Checking from pushover analysis	46
Chapter 4 Verifications for aluminium members	48
Symbols	48
Verification listing	49
Estimation of section class	49
Tension/compression (Axial)	50
Shear (Shear)	50
Bending with shear interaction (Bending)	51
Biaxial bending and axial load (BuckBending_biax and TensBending_biax)	51
Torsional buckling (TorsionBuckling)	51
Combined torsional buckling (TorsionBuck_comb)	51
Deflection checks	52

Chapter 5 Verifications for reinforced concrete members	53
Symbols	53
Verification listing	54
Ultimate Limit States	54
Serviceability Limit States	55
Seismic design	58
Geometric checks	58
Ductility checks	59
Shear	59
Column compression ratio	59
Beam-column joints	59
Capacity design	60
Detailing for beams	61
Detailing for columns	62
Shear verification in the plane for sliding walls (Sliding)	62
Checking FRP reinforcements	63
Checking from pushover analysis	64
Error codes	65
Chapter 6 Verifications for timber members	66
Symbols	66
Verification listing	67
Ultimate Limit States	67
Ultimate Limit States for CLT panels	69
Serviceability Limit States	70
Macroelement for CLT and fastener checks	71
Chapter 7 Verifications for thin steel profiles	74
Symbols	74
Verification listing	74
Base assumptions	75
Estimation of section class	76
Tension/compression (Axial)	76
Shear (Shear)	77
Bending with shear interaction (Bending)	77
Biaxial bending and axial load (BuckBending_biax and TensBending_biax)	77
Torsional buckling (TorsionBuckling)	77
Combined torsional buckling (TorsionBuck_comb)	78
Deflection checks	78
Chapter 8 Verifications for thin aluminium alloy profiles	79
Symbols	79

Verification listing	79
Base assumptions.....	80
Estimation of section class.....	81
Tension/compression (Axial)	81
Shear (Shear)	82
Bending with shear interaction (Bending)	82
Biaxial bending and axial load (BuckBending_biax and TensBending_biax).....	82
Torsional buckling (TorsionBuckling).....	82
Combined torsional buckling (TorsionBuck_comb).....	83
Deflection checks.....	83
Chapter 9 Verifications for masonry structures.....	84
Symbols	84
Verification listing	84
Tensile failure (TensileFailure).....	85
Vertical load stability (Axial).....	85
In-plane bending (InPlaneBending)	85
Out-of-plane bending (OutOfPlaneBending)	85
Sliding shear (Shear)	85
Reinforced masonry	86
Bending.....	86
Shear	86
Checking from pushover analysis.....	86

Chapter 1

Introduction

In this manual, analysis and verifications conducted with NextFEM Designer are showed and validated.

In the second paragraph, the program validation will be presented against some cases having easy analytical solution.

In the third paragraph, relationships used for steel member checking will be presented.

Such manual applies to the linear (static and dynamic) analyses only carried out with *NextFEM Designer* and with its default solver (*OOFEM*).

Supported design codes

The following references have been used:

1. EN 1993-1-1: Eurocode 3 - Design of steel structures - Part 1-1: General rules and rules for buildings
2. Italian Ministry of Infrastructures, D.M. 17-01-2018 (in the following, NTC2018) and Annex no. 617, 02/02/2009
3. EN 1999-1-1 (Eurocode 9)
4. EN 1992-1-1 (Eurocode 2)
5. EN 1995-1-1 (Eurocode 5)
6. EN 1993-1-3 (Eurocode 3 - cold-formed design)

Chapter 2

Analysis validation

In the following paragraph, a validation for structural analysis conducted with *NextFEM Designer* will be presented.

Types of analysis

Static analysis

The analysis performed is a structural static analysis. The solution of linear system of equations in the form $Ax=b$, produced by the Finite Elements Method, is obtained with linear systems solvers.

Load combinations are consistent with the ones proposed by Eurocode 3, and are written in the following form:

$$\gamma_{G1} \cdot G_1 + \gamma_{G2} \cdot G_2 + \gamma_{Q1} \cdot Q_{k1} + \gamma_{Q2} \cdot \psi_{02} \cdot Q_{k2} + \gamma_{Q3} \cdot \psi_{03} \cdot Q_{k3} + \dots$$

Partial safety factors:

- γ_{G1} : for self-weight loads, set as default to 1.5
- γ_{G2} : for permanent loads, set as default to 1.5
- γ_{Qi} : for variable loading, set as default to 1.5

Combination factors:

- ψ_{0i} : as default to 0.7 for variable loading
- ψ_{0i} : as default to 0.6 for wind loads
- ψ_{0i} : as default to 0.5 for snow loads (on the base of the height of the building site, < 1000m above sea level)

Such ULS (Ultimate Limit State) combinations are automatically generated by the program through the command **Assign/Load combinations.../Generate combos**. Please refer to the program users' manual for further information.

Origin and features of the program

The program is composed by 2 parts:

- Pre- and post-processor, NextFEM Designer (the program seen by the user), which handles input phase and results visualization, and also load combinations generation and verifications. This program is licensed to final user with the included license, that can be obtained with the command *?!About.../Product license*. *NextFEM Designer* is made by NextFEM, except for the packages listed in *?!About...*
- The default solver, *OOFEM*, is employed to perform the Finite Elements calculations. Other types of solvers can be set and used in the program, by they are not supported for this validation. *OOFEM* is licensed under LGPL conditions, reported in *?!About...* and included in the software package. This solver is developed by Prof. Borek Patzak (University of Prague) and by the *oofem.org* community.

Reliability of the program

This validation, including the hand calculation presented, is reported at Chapter 5 of the users' manual of NextFEM Designer. In the following, a reduced version with a particular focus on frame structures is reported.

Tutorial One

This tutorial will show how to model a 5 metres long fixed-ended beam, loaded with concentrated loads of 10kN in directions x, y and z in the middle of its span. The results from NextFEM Designer (Frame forces and displacement) are compared with hand calculations.

⚠ WARNING: Both flexural and shear deformations are considered. To enable this option, click on *Tools>Option>Solver* and check the *Include shear deformations in beam elements* tick under the *OOFEM preferences* box

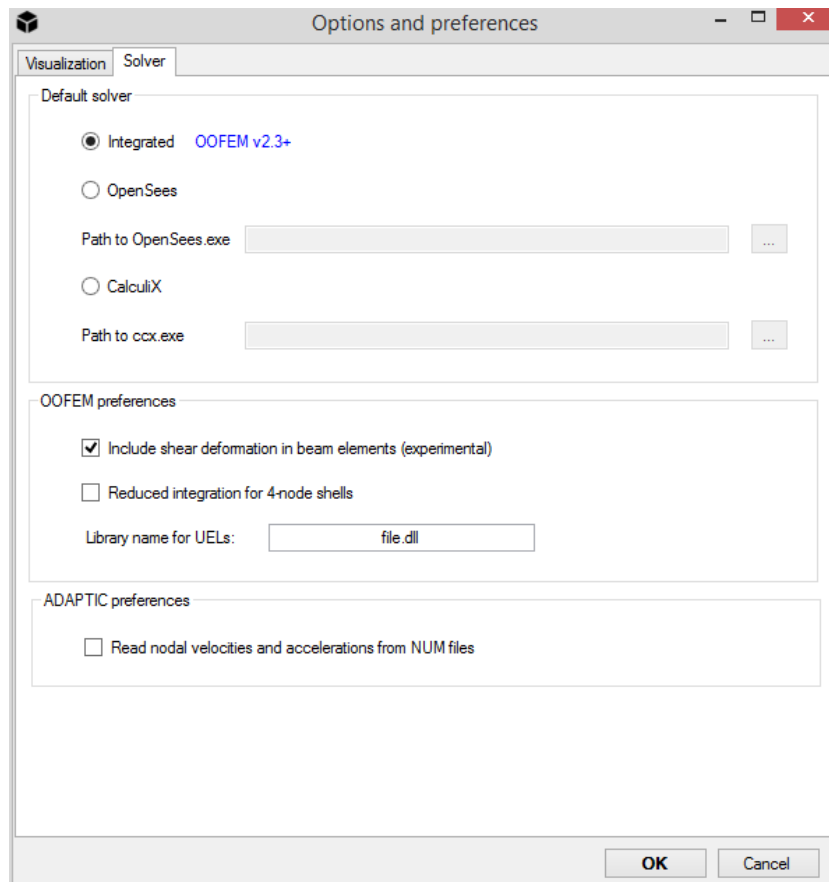

The following sequence of operations are needed to create the model:

1. Set the Units: *N* for force and *mm* for length.

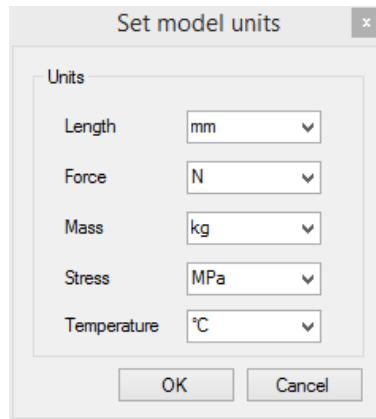

2. Define the Material properties:
 - o Name: Concrete;
 - o $E=30000 \text{ N/mm}^2$;
 - o $\nu=0.3$
 - o $f_k=25 \text{ N/mm}$
 - o $\text{Weight}=2.5e-5 \text{ N/mm}^3$;
 - o $\text{Mass}=2.55e-9 \text{ N/mm}^2/\text{g}$

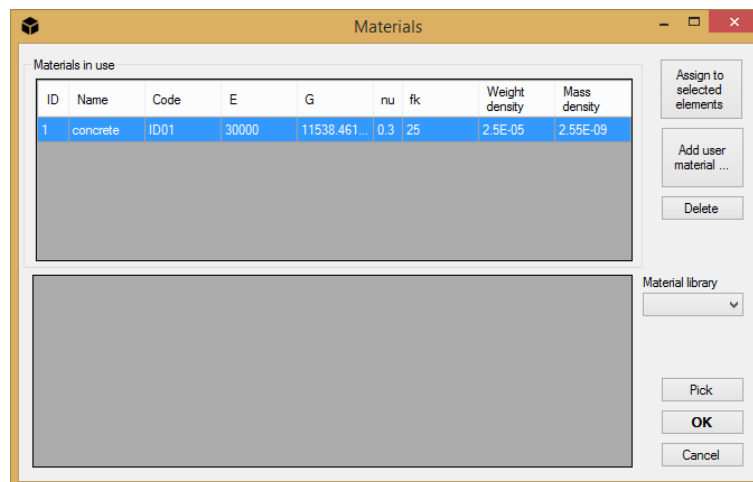

3. Define the Section properties:
 - o $b=300 \text{ mm}$ (z direction);
 - o $h=500\text{mm}$ (y direction);

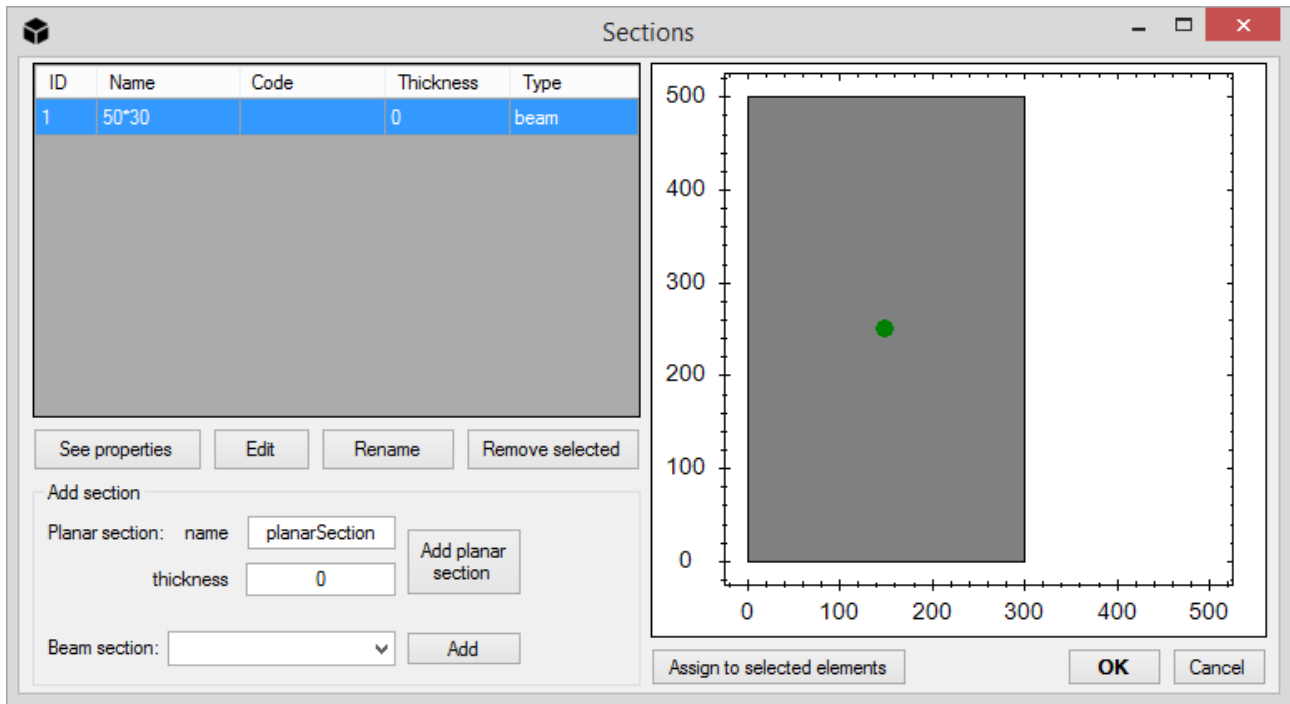

4. Define the Loads cases: Only one load case called *Qk1* is considered

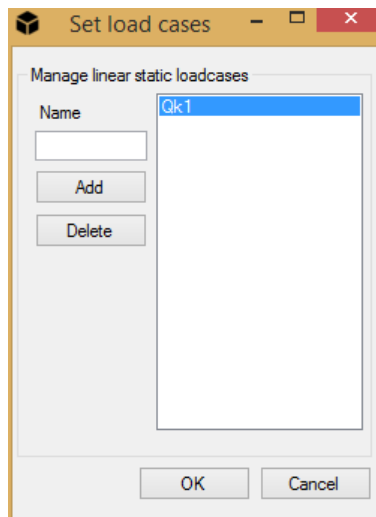

5. Insert the Geometric properties using *Node by Coordinates*:

- o L=5000 mm;
- o Distance from fixed end to loads=2500 mm;

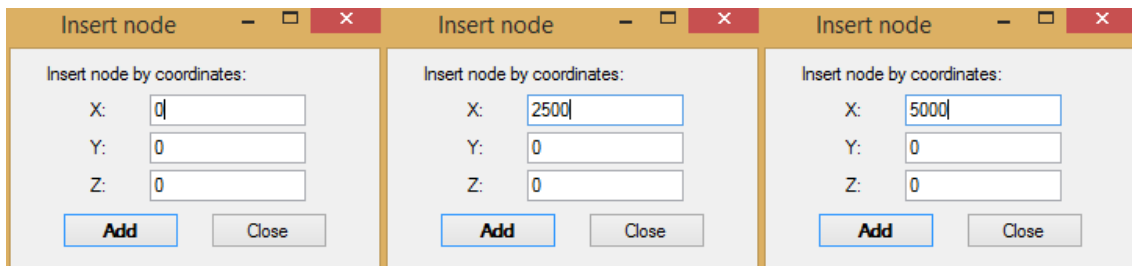

6. Insert the beams using the *Beam* command.

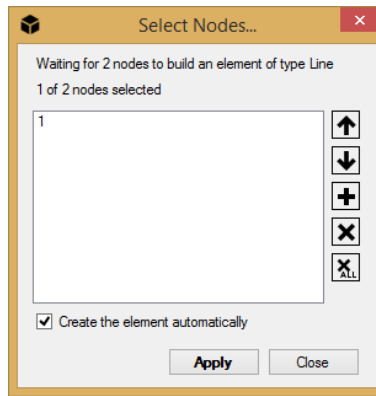

7. Assign the boundary conditions using the *Restraints* command: fix all DoFs for nodes 1 and 3.

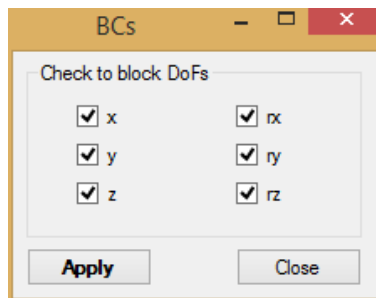

8. Assign the material using the *Assign>Material* command at the beams by selecting them and then click on *Assign to selected elements*

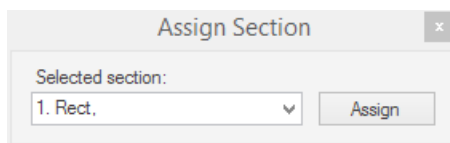

9. Assign the section using the *Assign>Section* command at the beams by selecting them and then click on *Assign*

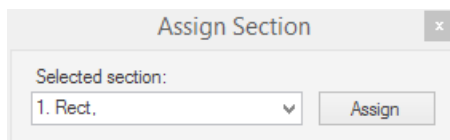

10. Assign the point load to the node number 2.
 - o $P_x=10000$ N;
 - o $P_y=10000$ N;
 - o $P_z=-10000$ N.

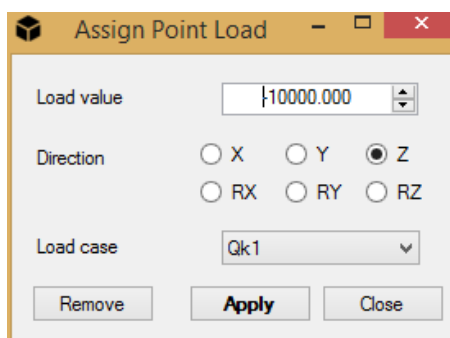

11. Run the analysis.

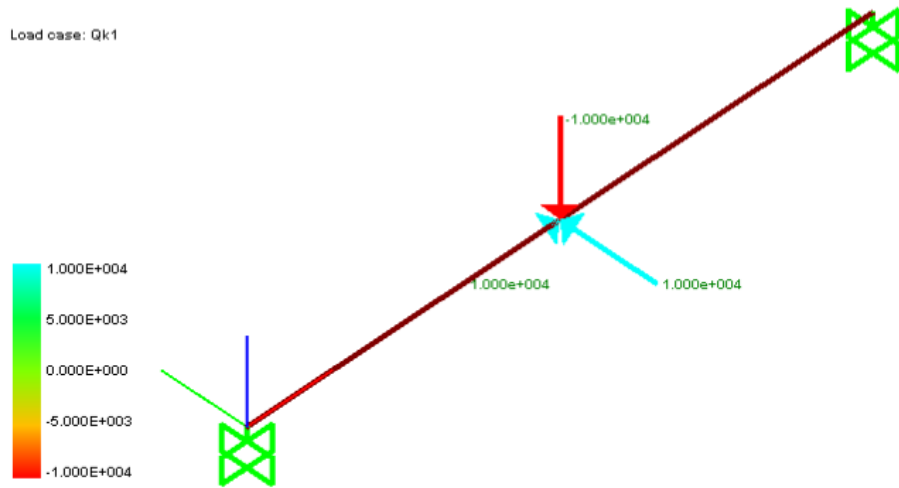

- NextFEM Designer's Results:

- o Displacement in x direction: Node 2= 0.002778mm

Node Displacements
Component: x

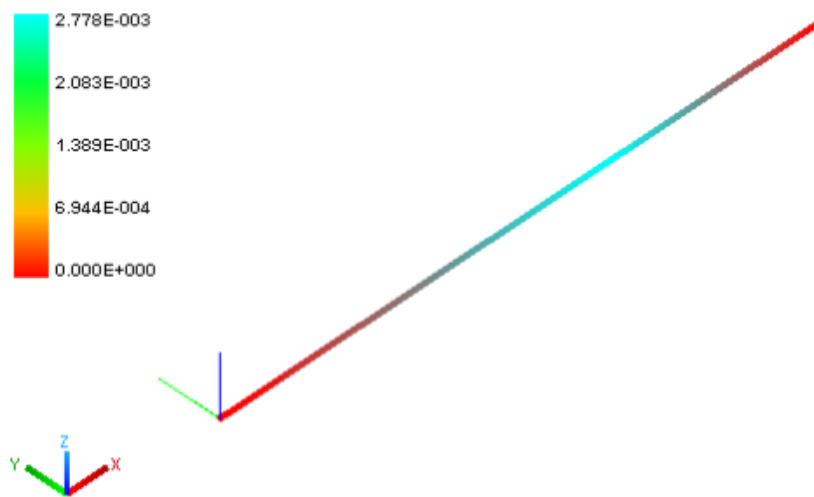

- o Displacement in y direction: Node 2= 0.2016mm

Node Displacements
Component: y

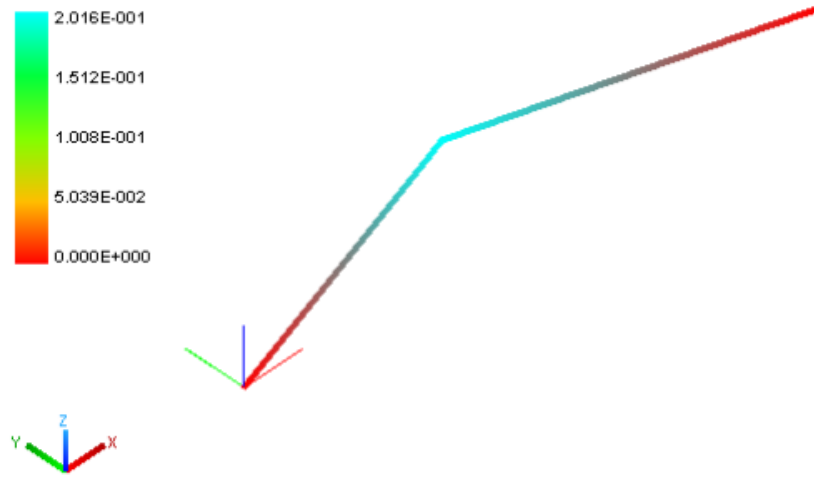

- o Displacement in z direction: Node 2=-0.00781 mm

Node Displacements
Component: z

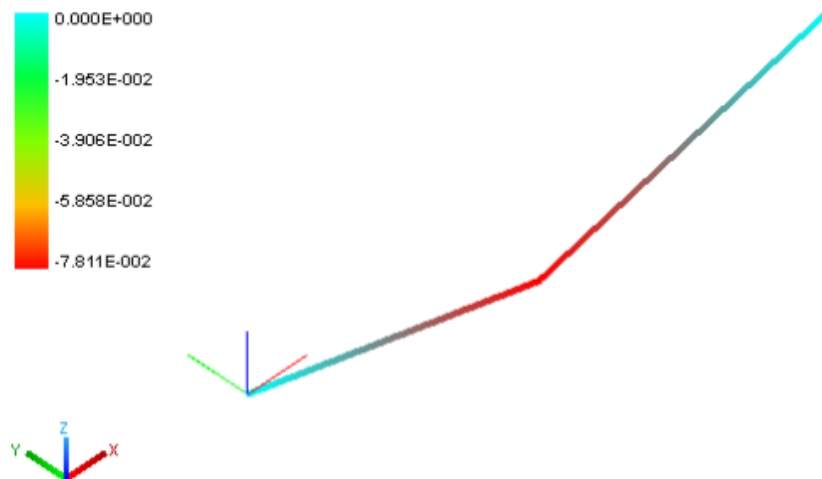

- o Moment Diagram: Values from *Results>Extract Data*
 - Mzz

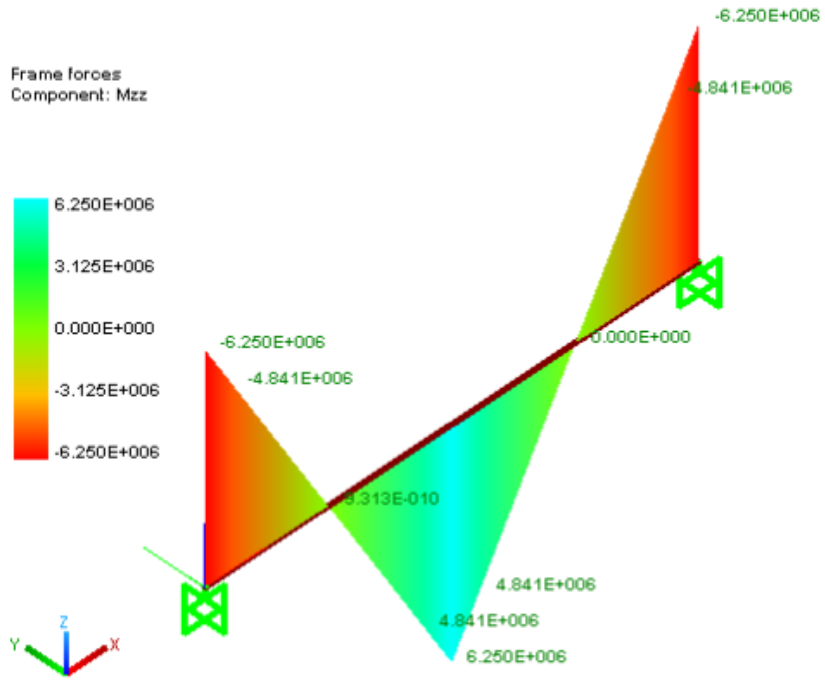

- Myy

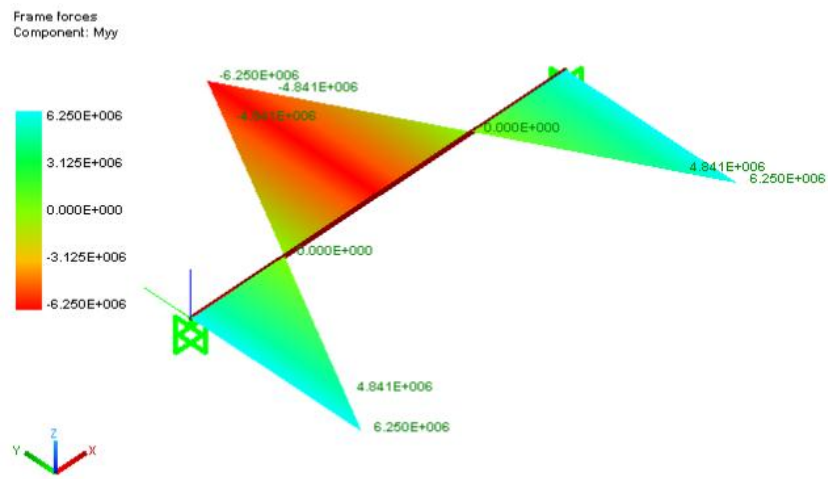

- Shear Diagram:

- Vy

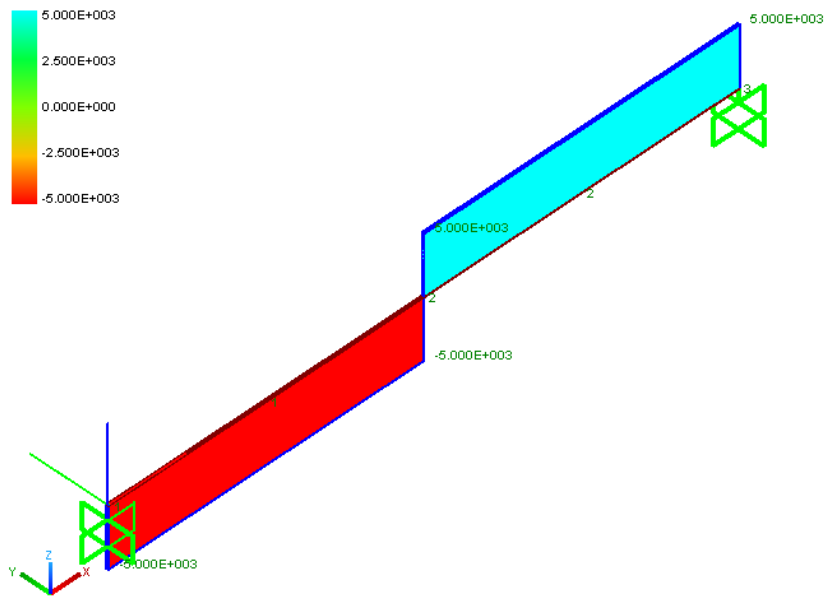

■ Vz

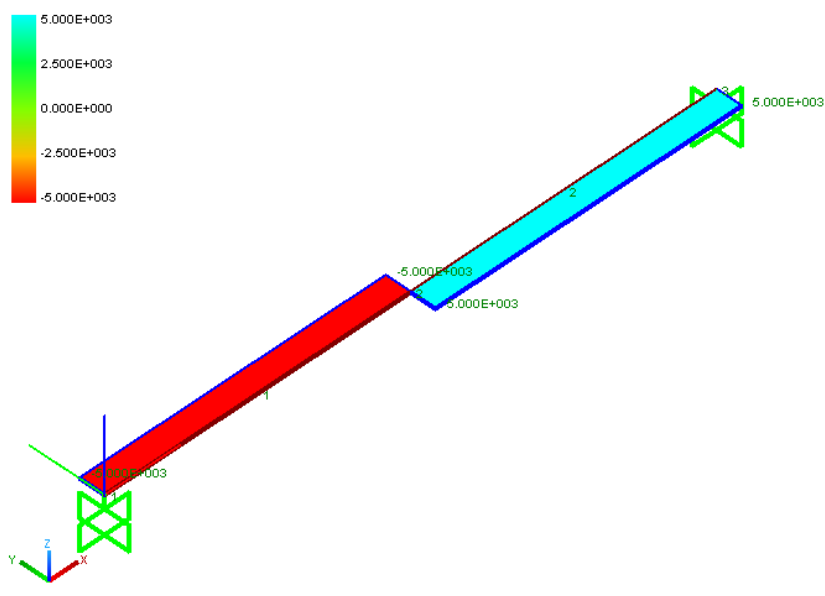

○ Normal forces Diagram:

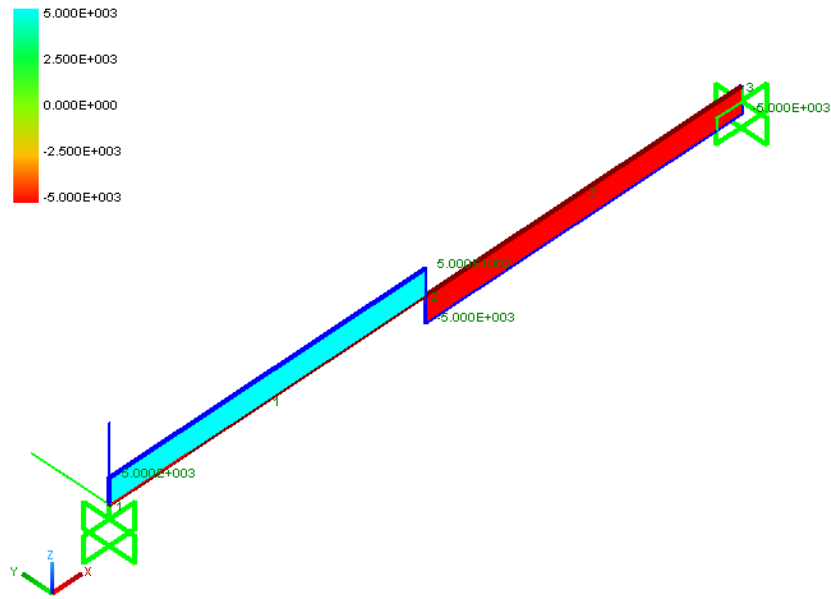

- Internal displacements in y direction: values from *Results>Extract data*

Position [mm]	Displacement [mm]
0	0
281.8	0.00778
1250	0.1008
2218	0.1938
2500	0.2016
2500	0.2016
2781.8	0.1938
3750	0.1008
4718	0.00778
5000	0

- Internal displacements in z direction: values from *Results>Extract data*

Position [mm]	Displacement [mm]
0	0
281.8	-0.003424
1250	-0.03906
2218	-0.07469
2500	-0.07811
2500	-0.07811
2781.8	-0.07469
3750	-0.03906
4718	-0.003424
5000	0

- Hand Calculations:

- Section properties

$$A = b \cdot h = 150000 \text{mm}^2$$

$$J_y = \frac{bh^3}{12} = 3125e6 \text{mm}^4$$

$$J_z = \frac{hb^3}{12} = 1125e6 \text{mm}^4$$

- Moment diagram:

- Mzz

$$M_{\max} = \frac{Pl}{8} = 6250000 \text{ Nmm} ; M_{\min} = -\frac{Pl}{8} = -6250000 \text{ Nmm}$$

▪ Myy

$$M_{\max} = \frac{Pl}{8} = 6250000 \text{ Nmm} ; M_{\min} = -\frac{Pl}{8} = -6250000 \text{ Nmm}$$

○ Shear Diagram:

▪ Vy

$$V_{\max} = \frac{P_z}{2} = 5000 \text{ N} ; V_{\min} = -\frac{P_z}{2} = -5000 \text{ N}$$

▪ Vz

$$V_{\max} = \frac{P_y}{2} = 5000 \text{ N} ; V_{\min} = -\frac{P_y}{2} = -5000 \text{ N}$$

○ Axial force Diagram:

$$N_{\max} = \frac{P_x}{2} = 5000 \text{ N} ; N_{\min} = -\frac{P_x}{2} = -5000 \text{ N}$$

○ Displacement in x direction: Node2

$$u_{2,x} = \frac{N_{\max}(l/2)}{EA} = 0.00278 \text{ mm}$$

○ Displacement in y direction: Node 2

$$u_{2,y} = \frac{1}{192} \frac{P_y l^3}{EJ_z} + \chi \frac{P_y l}{4GA} = 0.201568 \text{ mm}$$

○ Displacement in z direction: Node 2

$$u_{2,z} = \frac{1}{192} \frac{P_z l^3}{EJ_y} + \chi \frac{P_z l}{4GA} = -0.07811 \text{ mm}$$

○ Displacement in y direction: internal point at the coordinate x

$$u_{x,y} = \frac{1}{24} \frac{P_y x^2 \left(\frac{3}{2} l - 2x \right)}{EJ_z} + \chi \frac{P_y x}{2GA} \text{ for } 0 \leq x \leq L/2$$

$$u_{x,y} = \frac{1}{24} \frac{P_y (L-x)^2 \left(2x - \frac{L}{2} \right)}{EJ_z} + \chi \frac{P_y (L-x)}{2GA} \text{ for } L/2 \leq x \leq L$$

Position [mm]	Displacement [mm]
0	0
281.8	0.00778
1250	0.1008
2218	0.1938
2500	0.2016
2500	0.2016
2781.8	0.1938
3750	0.1008
4718	0.00779
5000	0

- Displacement in z direction: internal point at the coordinate x

$$u_{x,z} = \frac{1}{24} \frac{P_z x^2 \left(\frac{3}{2} l - 2x \right)}{EJ_y} + \chi \frac{P_z x}{2GA} \text{ for } 0 \leq x \leq L/2$$

$$u_{x,z} = \frac{1}{24} \frac{P_z (L-x)^2 \left(2x - \frac{L}{2} \right)}{EJ_y} + \chi \frac{P_z (L-x)}{2GA} \text{ for } L/2 \leq x \leq L$$

Position [mm]	Displacement [mm]
0	0
281.8	-0.003425
1250	-0.03906
2218	-0.07468
2500	-0.07811
2500	-0.07811
2781.8	-0.07469
3750	-0.03906
4718	-0.003429
5000	0

Tutorial Two

The second tutorial consists in a cantilever beam loaded with points load in directions y and z. The output results of NextFEM Designer (Frame forces and displacement) are compared with hand calculations.

Case a

 Only flexural deformations are considered.

- Units: N for forces and mm for lengths.
- Material Properties:
 - Name: Concrete;
 - E=30000 N/mm²;
 - Nu=0.3
 - Fk=25 N/mm
 - Weight=2.5e-5 N/mm³;
 - Mass=2.55e-9 N/mm²/g
- Section properties:
 - B=300 mm (z direction);
 - H=500mm (y direction);
- Geometric properties:
 - L=2500 mm;
- Loads:
 - Py=5000 N;
 - Pz=-10000 N.

Load case: Qk1

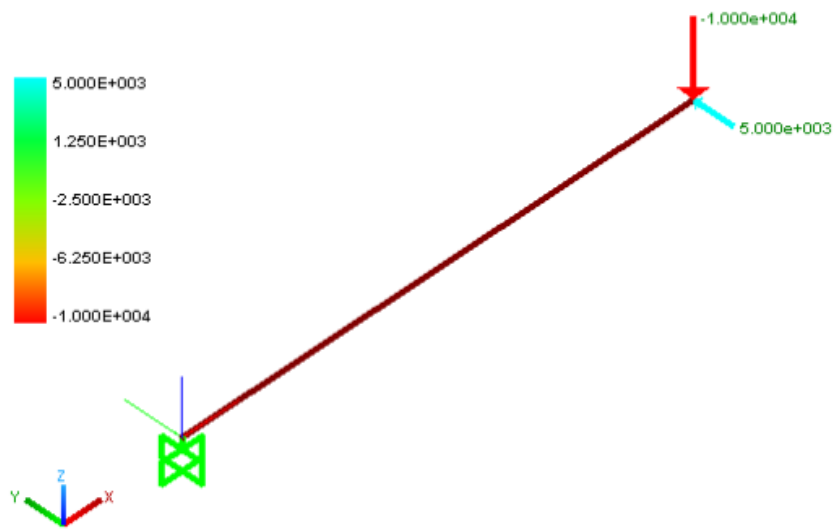

- NextFEM Designer's results:

- o Displacement in x direction: Node 2=0.00mm

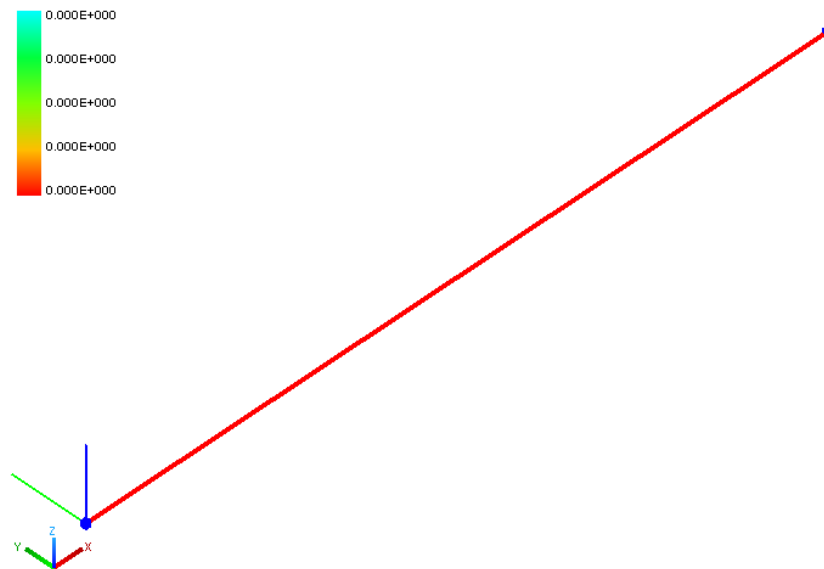

- o Displacement in y direction: Node 2=0.7716mm

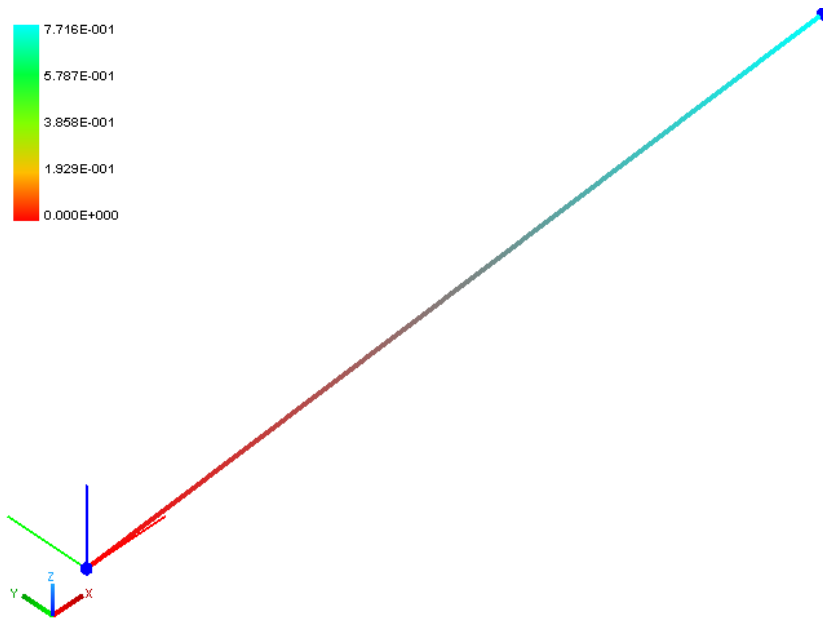

- o Displacement in z direction: Node 2=-0.5556mm

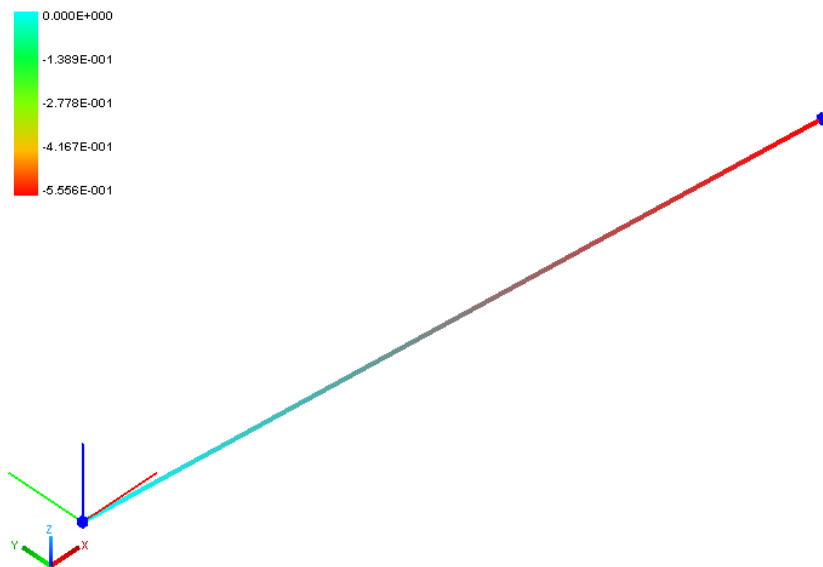

- o Moment Diagram: Values from *Results>Extract Data*
 - Mzz

Frame forces
Component: Mzz

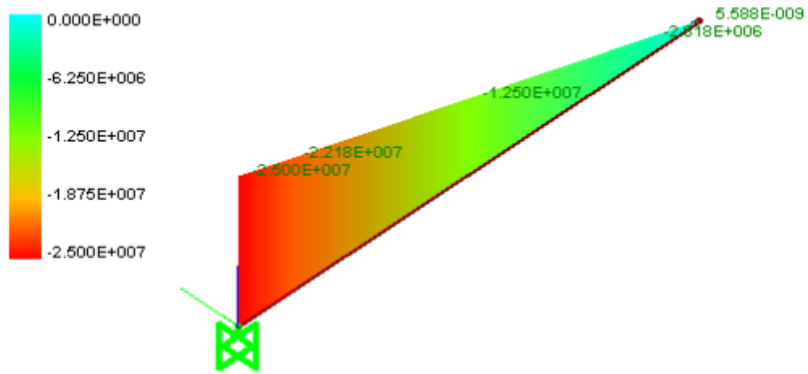

Y Z X
■ Myy

Frame forces
Component: Myy

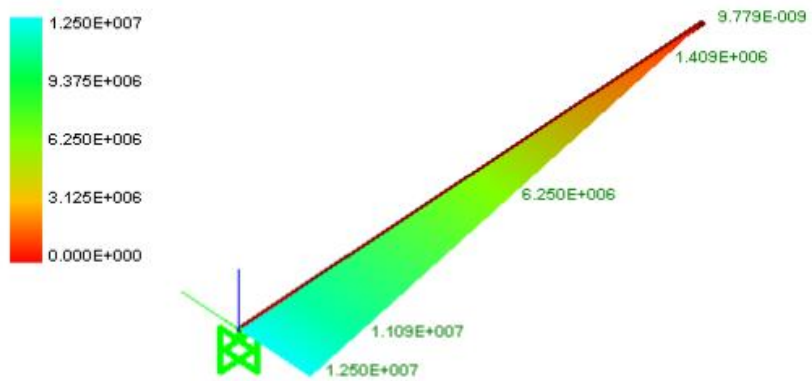

Y Z X

- Shear Diagram:
 - Vy

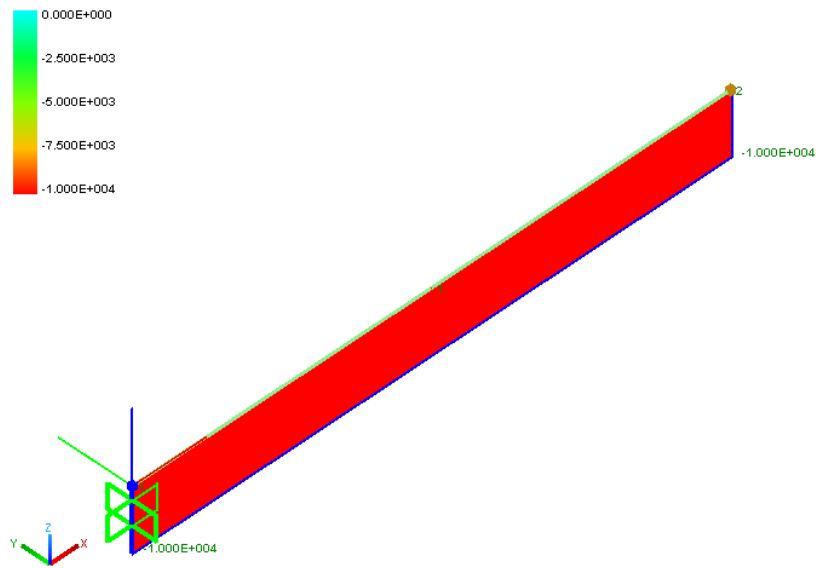

■ Vz

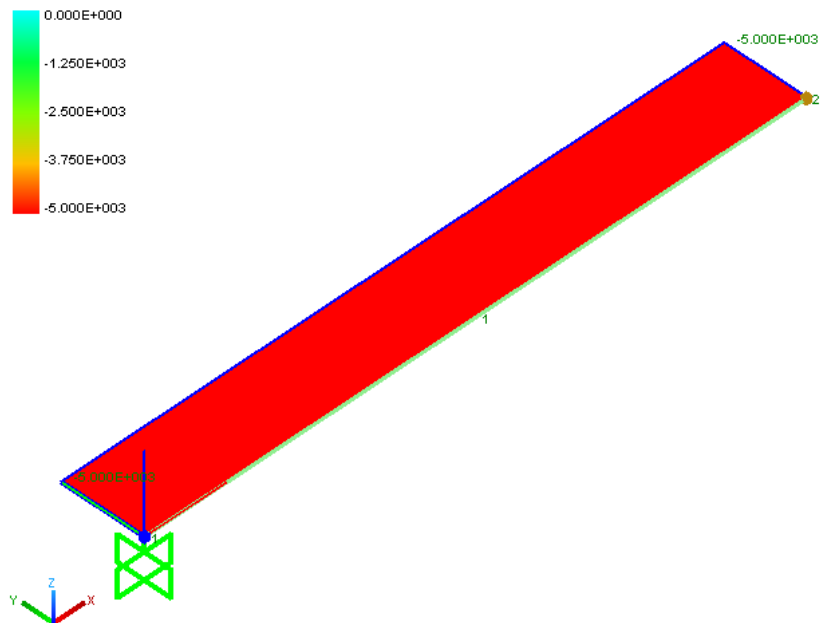

- o Internal displacement in y direction: values from *Results>Extract data*

Position [mm]	Displacement [mm]
0	0
281.8	0.01415
1250	0.2411
2218	0.6417
2500	0.7716

- o Internal displacement in z direction: values from *Results>Extract data*

Position [mm]	Displacement [mm]
0	0
281.8	-0.01019
1250	-0.1736
2218	-0.4620
2500	-0.5556

- Hand Calculations:

- o Moment diagram:

- Mzz

$$M_{\max} = P_z l = 25000000 \text{ Nmm} ;$$

- Myy

$$M_{\max} = P_y l = 12500000 \text{ Nmm}$$

- o Shear Diagram:

- Vy

$$V_{\max} = P_z = 10000 \text{ N} ;$$

- Vz

$$V_{\max} = P_y = 5000 \text{ N} ;$$

- o Axial force Diagram:

$$N_{\max} = 0 \text{ N} ;$$

- o Displacement in x direction: Node 2

$$u_{2,x} = 0$$

- o Displacement in y direction: Node 2

$$u_{2,y} = \frac{1}{3} \frac{P_y l^3}{EJ_z} = 0.77160 \text{ mm}$$

- o Displacement in z direction: Node 2

$$u_{2,z} = \frac{1}{3} \frac{P_z l^3}{EJ_y} = -0.5556 \text{ mm}$$

- o Displacement in y direction: point at coordinate x

$$u_{x,y} = \frac{1}{6} \frac{P_y x^2 (3l - x)}{EJ_z}$$

Coordinate x [mm]	Displacement [mm]
0	0
281.8	0.01415
1250	0.2411
2218	0.6416
2500	0.7716

- o Displacement in z direction: point at coordinate x

$$u_{x,z} = \frac{1}{6} \frac{P_z x^2 (3l - x)}{EJ_y}$$

Coordinate x [mm]	Displacement [mm]
0	0
281.8	-0.01019
1250	-0.1736
2218	-0.4620
2500	-0.5556

Case b

⚠ Both flexural and shear deformations are considered. To enable this option, click on Tools>Option>Solver and check the Include shear deformations in beam elements tick under the OOFEM preferences box

- Units: N for forces and mm for lengths.
- Material Properties:
 - o Name: Concrete;
 - o $E=30000 \text{ N/mm}^2$;
 - o $\nu=0.3$
 - o $F_k=25 \text{ N/mm}$
 - o $\text{Weight}=2.5\text{e-}5 \text{ N/mm}^3$;
 - o $\text{Mass}=2.55\text{e-}9 \text{ N/mm}^2/\text{g}$
- Section properties:
 - o $B=300 \text{ mm}$ (z direction);
 - o $H=500\text{mm}$ (y direction);
- Geometric properties:
 - o $L=2500 \text{ mm}$;
- Loads:
 - o $P_y=5000 \text{ N}$;
 - o $P_z=-10000 \text{ N}$.

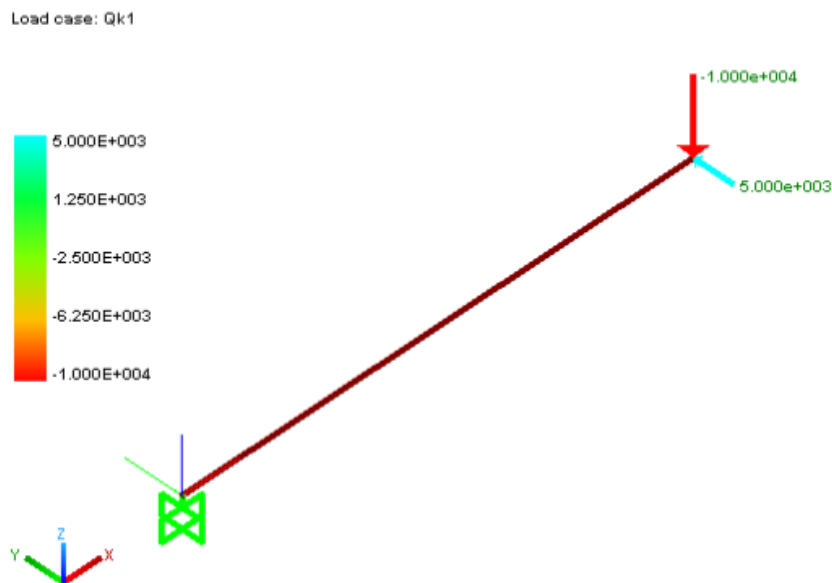

- NextFEM Designer's results:
 - o Displacement in x direction: Node 2=0.00mm

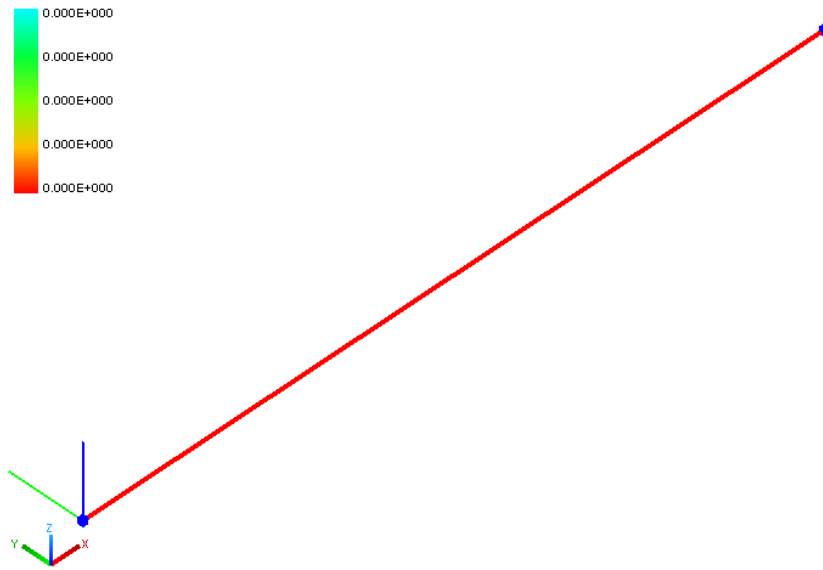

- Displacement in y direction: Node 2=0.7803mm

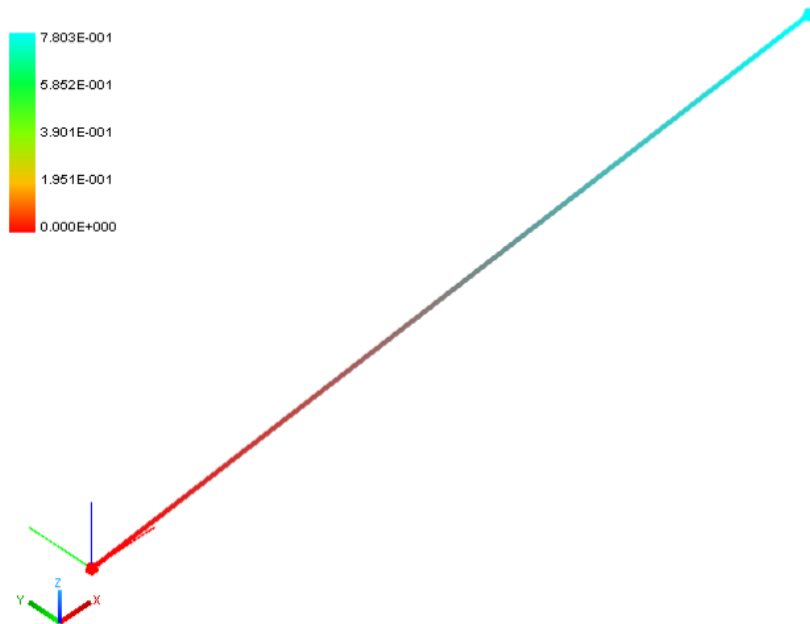

- Displacement in z direction: Node 2=-0.5729mm

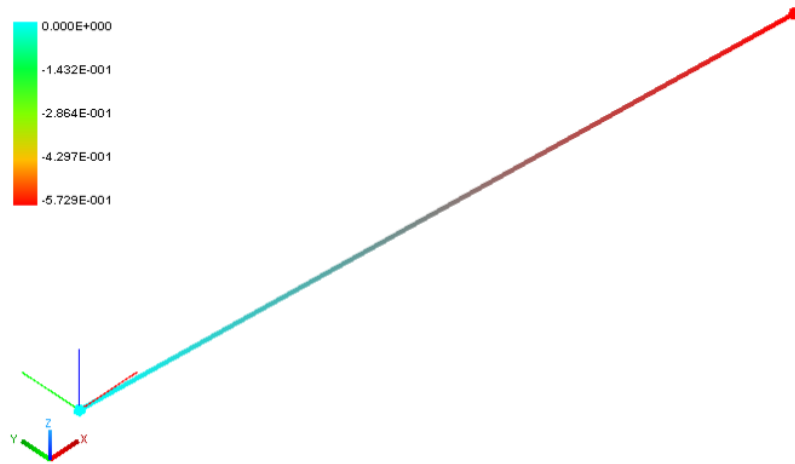

- o Moment Diagram: Values from *Results>Extract Data*
 - Mzz

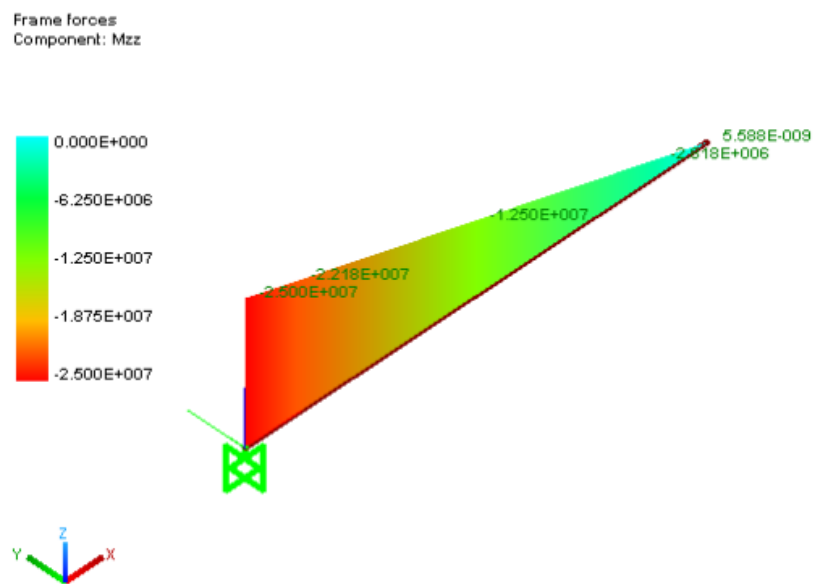

- Myy

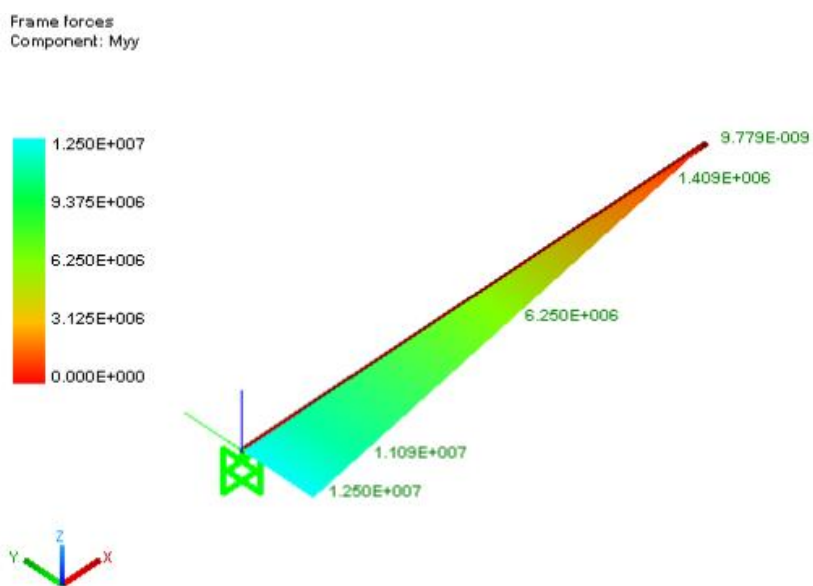

○ Shear Diagram:

▪ V_y

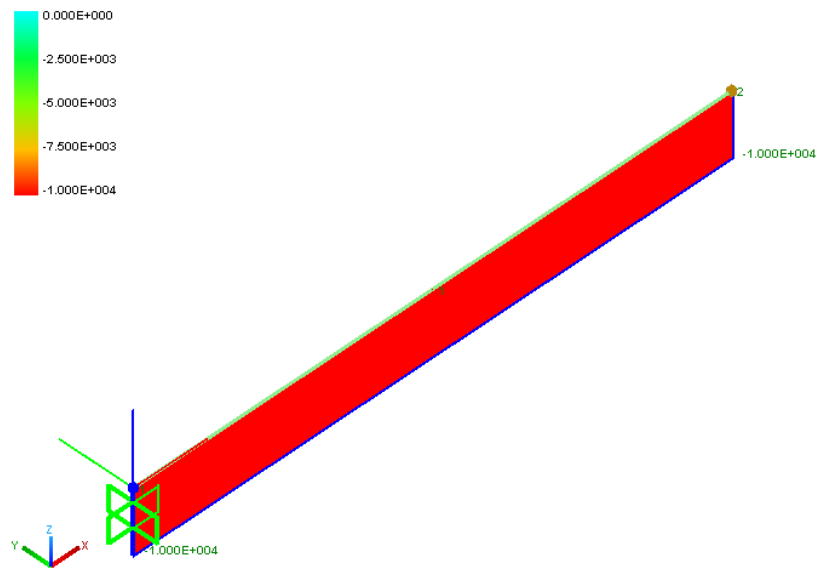

▪ V_z

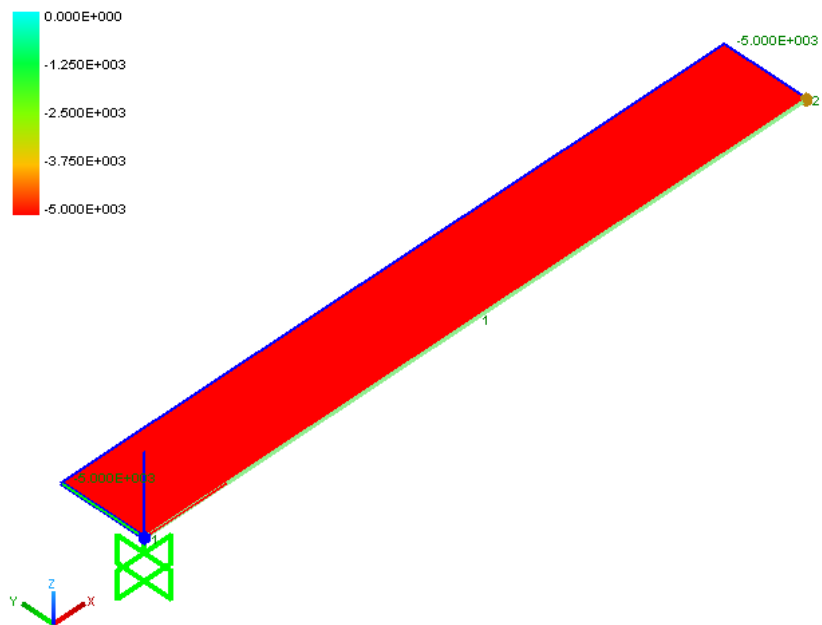

○ Internal displacement in y direction: values from *Results>Extract data*

Position [mm]	Displacement [mm]
0	0
281.8	0.01513
1250	0.2455
2218	0.6494
2500	0.7803

○ Internal displacement in z direction: values from *Results>Extract data*

Position [mm]	Displacement [mm]
---------------	-------------------

0	0
281.8	-0.01214
1250	-0.1823
2218	-0.4774
2500	-0.5729

- Hand Calculations:

- o Moment diagram:
 - Mzz

$$M_{\max} = P_z l = 25000000 \text{ Nmm} ;$$

- Myy

$$M_{\max} = P_y l = 12500000 \text{ Nmm}$$

- o Shear Diagram:

- Vy

$$V_{\max} = P_z = 10000 \text{ N} ;$$

- Vz

$$V_{\max} = P_y = 5000 \text{ N} ;$$

- o Axial force Diagram:

$$N_{\max} = 0 \text{ N} ;$$

- o Displacement in x direction: Node 2

$$u_{2,x} = 0 \text{ mm}$$

- o Displacement in y direction: Node 2

$$u_{2,y} = \frac{1}{3} \frac{P_y l^3}{EJ_z} + \chi \frac{P_y l}{GA} = 0.7803 \text{ mm}$$

- o Displacement in y direction: point at coordinate x

$$u_{x,y} = \frac{1}{6} \frac{P_y x^2 (3l - x)}{EJ_z} + \chi \frac{P_y x}{GA}$$

Coordinate x [mm]	Displacement [mm]
0	0
281.8	0.01513
1250	0.2455
2218	0.6493
2500	0.7803

- o Displacement in z direction: Node 2

$$u_{2,z} = \frac{1}{3} \frac{P_z l^3}{EJ_y} + \chi \frac{P_z l}{GA} = -0.5729 \text{ mm}$$

- o displacement in z direction: point at coordinate x

$$u_{x,z} = \frac{1}{6} \frac{P_z x^2 (3l - x)}{EJ_y} + \chi \frac{P_z x}{GA}$$

Coordinate x [mm]	Displacement [mm]
0	0
281.8	-0.01214
1250	-0.1823
2218	-0.4773
2500	-0.5729

Tutorial Three

The third tutorial consists in a cantilever beam loaded with points load in direction y with modelled by shell elements (Mindlin-Reissner theory). The output results of NextFEM Designer (Frame forces and displacement) are compared with hand calculations.

⚠ Only flexural deformations are considered.

- Units: N for forces and mm for lengths.
- Material Properties:
 - o Name: Concrete;
 - o $E=30000 \text{ N/mm}^2$;
 - o $\nu=0.3$
 - o $F_k=25 \text{ N/mm}$
 - o $\text{Weight}=2.5e-5 \text{ N/mm}^3$;
 - o $\text{Mass}=2.55e-9 \text{ N/mm}^2/\text{g}$
- Section properties:
 - o $B=300 \text{ mm}$ (y direction); Planar section;
- Geometric properties:
 - o $L=5000 \text{ mm}$;
- Loads:
 - o $P_y=5000 \text{ N}$;
 - o $P_z=10000 \text{ N}$;
- Mesh size: $250 \times 250 \text{ mm}$

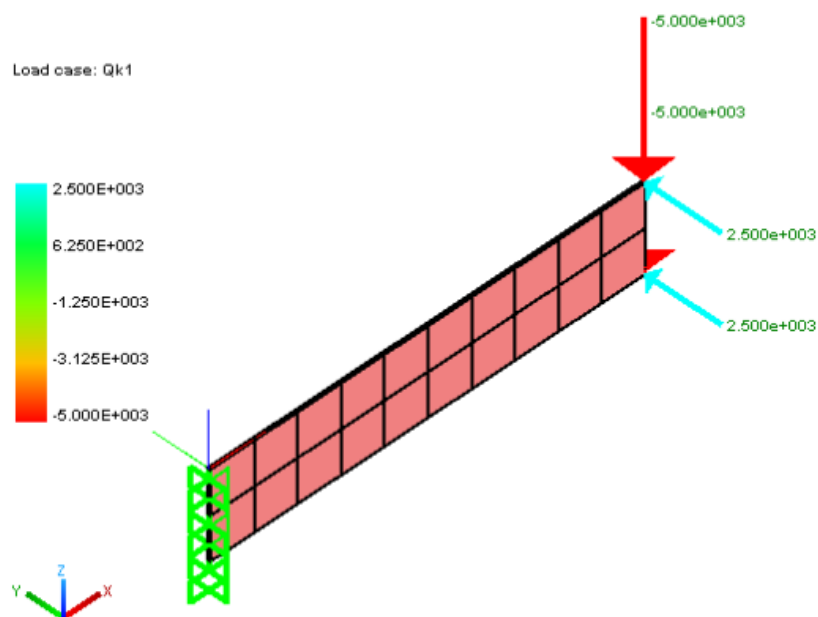

- NextFEM Designer's Results:

- Displacement in x direction: Node 2=0.00mm

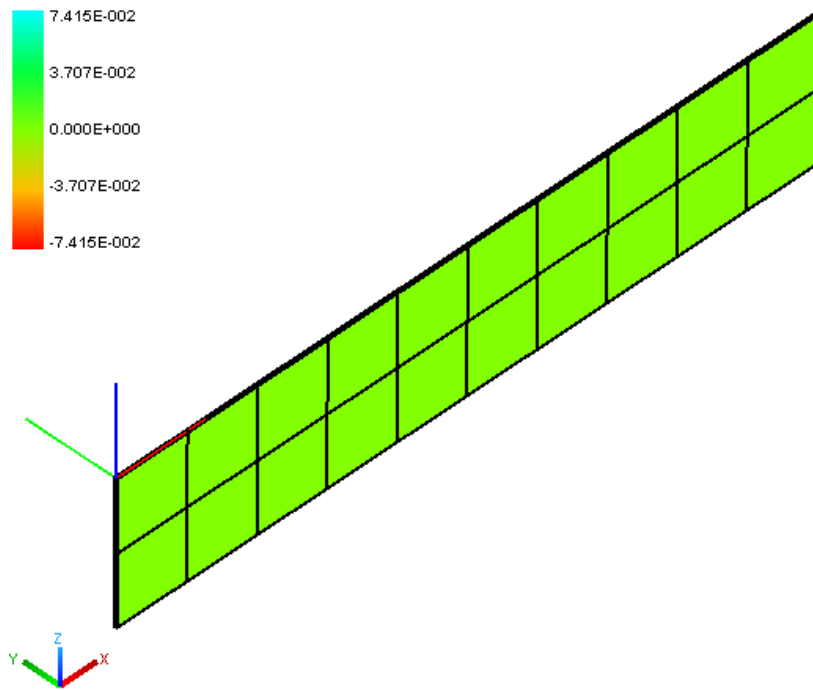

- Displacement in y direction: Node 2=0.6250 mm

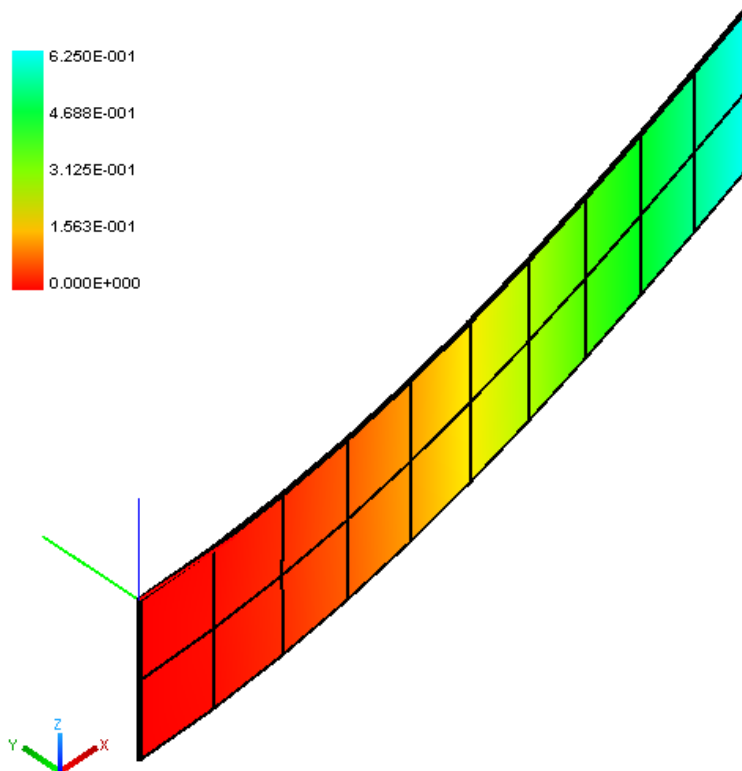

- Displacement in z direction: Node 2=-0.5062mm

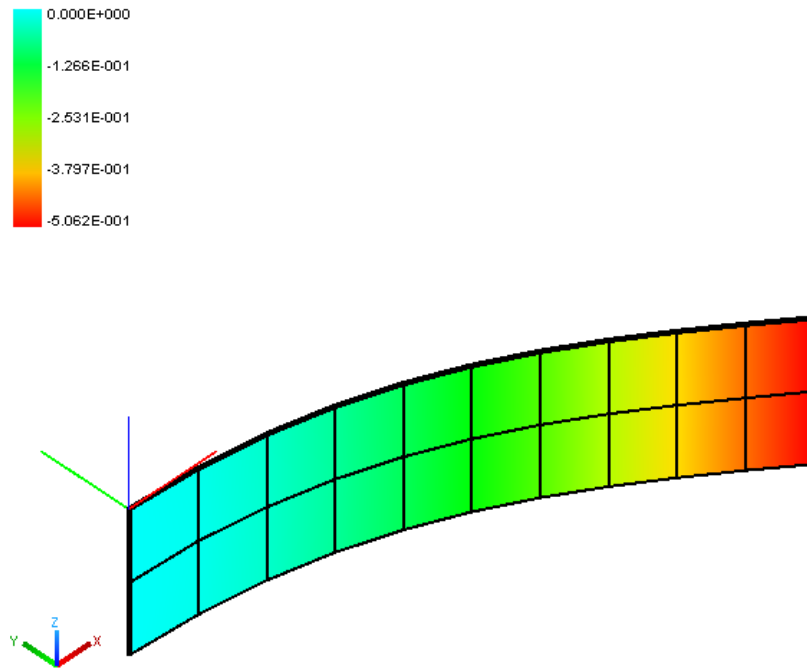

- Comparison with hand Calculations (see tutorial two):
 - o Displacement in y direction
 - Hand Calculation: 0.77160mm
 - NextFEM designer: 0.6250mm
 - Percent difference 19%
 - o Displacement in z direction:
 - Hand Calculation: -0.5556mm
 - NextFEM designer: -0.5062mm
 - Percent difference: 9%

Note that the difference is due to the choice of the mesh size.

Tutorial Four

The fourth tutorial consists in a cantilever beam loaded with distributed loads in directions x, y and z. The output of NextFEM Designer (Frame forces and displacement) is compared with hand calculations.

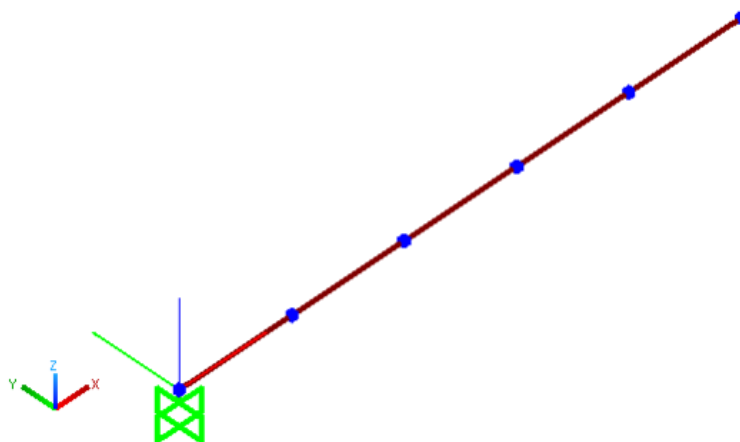

⚠ Only flexural deformations are considered.

- Units: N for forces and mm for lengths.
- Material Properties:

- Name: Concrete;
- $E=30000 \text{ N/mm}^2$;
- $\nu=0.3$
- $F_k=25 \text{ N/mm}$
- $\text{Weight}=2.5\text{e-}5 \text{ N/mm}^3$;
- $\text{Mass}=2.55\text{e-}9 \text{ N/mm}^2/\text{g}$
- Section properties:
 - $B=300 \text{ mm}$ (y direction);
 - $H=500\text{mm}$ (z direction);
- Geometric properties:
 - $L=5000 \text{ mm}$;
- Loads properties:
 - $q_y=1 \text{ N/mm}$;
 - $q_z=-1 \text{ N/mm}$;
 - $q_x=-1 \text{ N/mm}$.

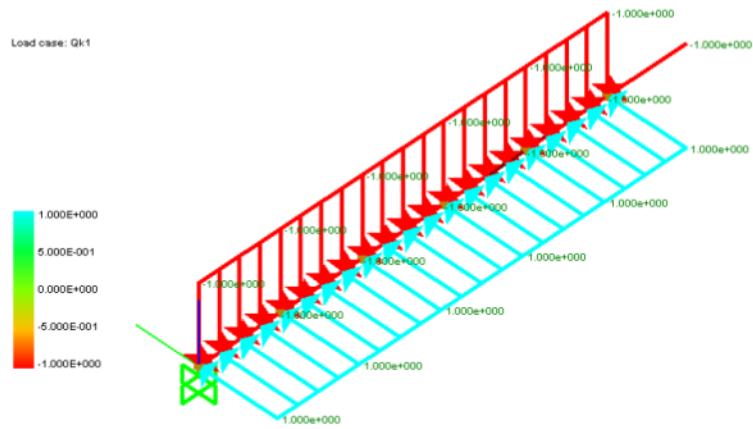

- NextFEM Designer's Results:
 - Displacement in x direction: Node 6=-0.00278mm

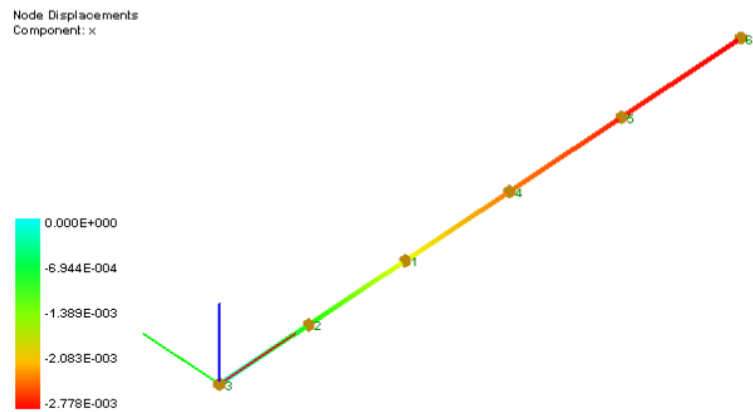

- Displacement in y direction: Node 6=2.315mm

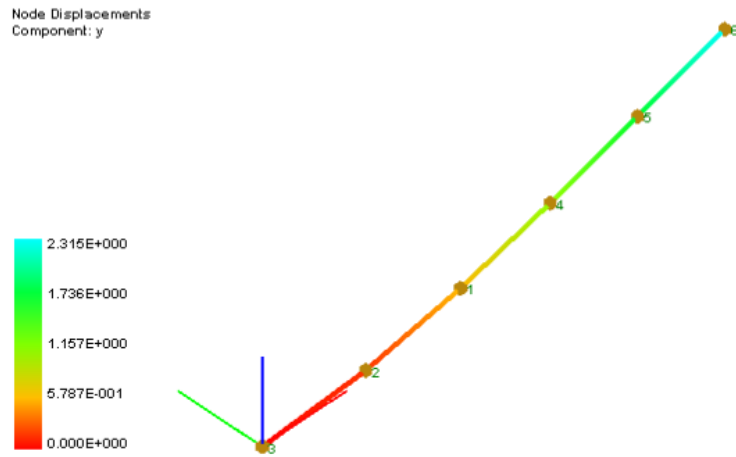

- o Displacement in z direction: Node 6=-0.8333mm

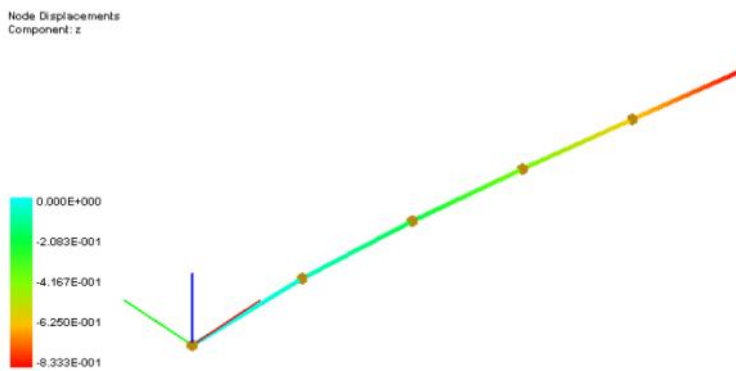

- o Moment Diagram: Values from *Results>Extract Data*
 - Mzz max: node 1: 125000000000 Nmm

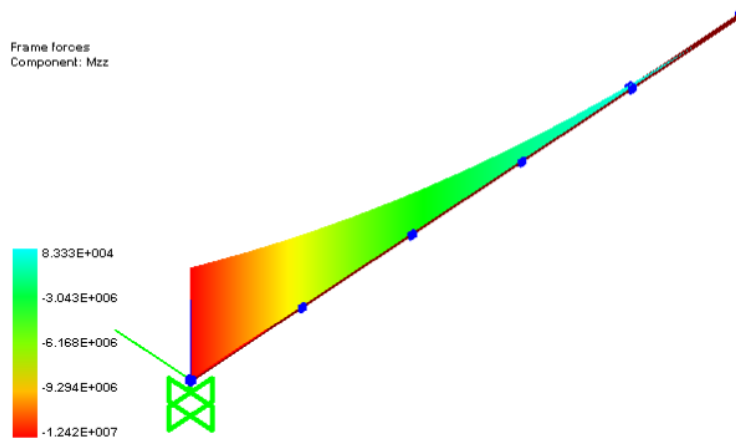

- Myy max: node 1: 125000000000 Nmm

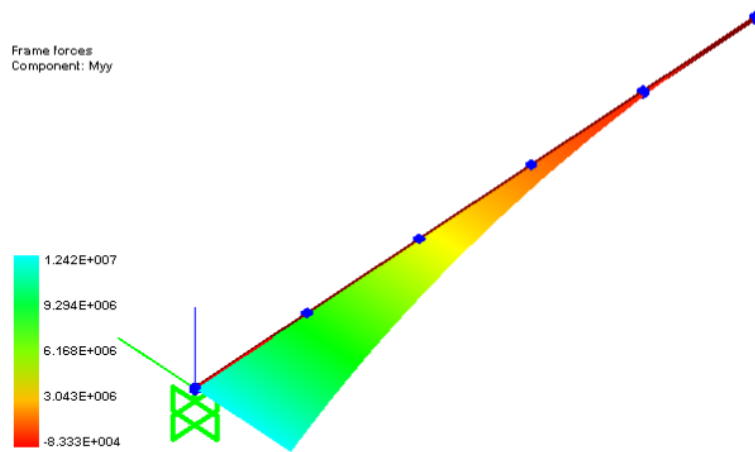

- Shear Diagram:
 - Vy

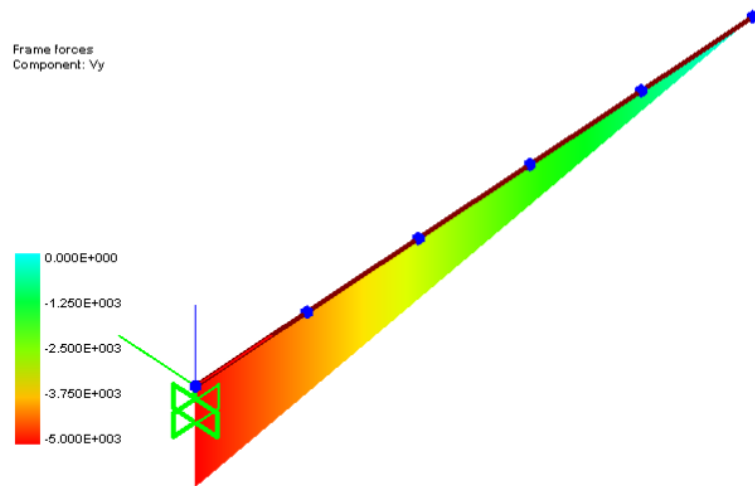

- Vz

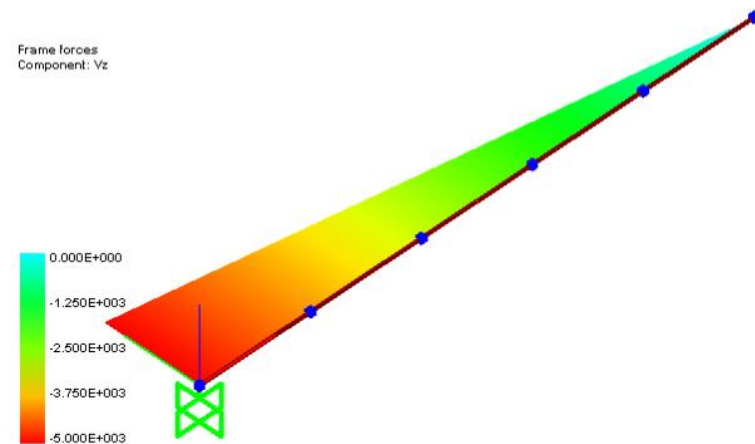

- Hand Calculations:

- Moment diagram:

- Mzz

$$M_{\max} = \frac{q_z l^2}{2} = 125000000000 \text{ Nmm} ;$$

- Myy

$$M_{\max} = \frac{q_y l^2}{2} = 125000000000 \text{ Nmm} ;$$

- Shear Diagram:

- V_y

$$V_{\max} = q_z l = 5000 \text{ N} ;$$

- V_z

$$V_{\max} = q_y l = 5000 \text{ N} ;$$

- Axial force diagram:

$$N_{\max} = q_x l = 5000 \text{ N} ;$$

- Max Displacement in x direction: Node 6

$$u_{6,x} = \frac{q_x l^2}{2EA} = 0.00278 \text{ mm}$$

- Max Displacement in y direction: Node 6

$$u_{6,y} = \frac{q_y l^4}{8EJ_y} = 2.315 \text{ mm}$$

- Max Displacement in z direction: Node 6

$$u_{6,z} = \frac{q_z l^4}{8EJ_z} = -0.8333 \text{ mm}$$

Tutorial Five

The fifth tutorial consists in a modal analysis of a 3D wooden frame-building . The output of NextFEM Designer (modes of vibration) is compared with the output of SAP2000®.

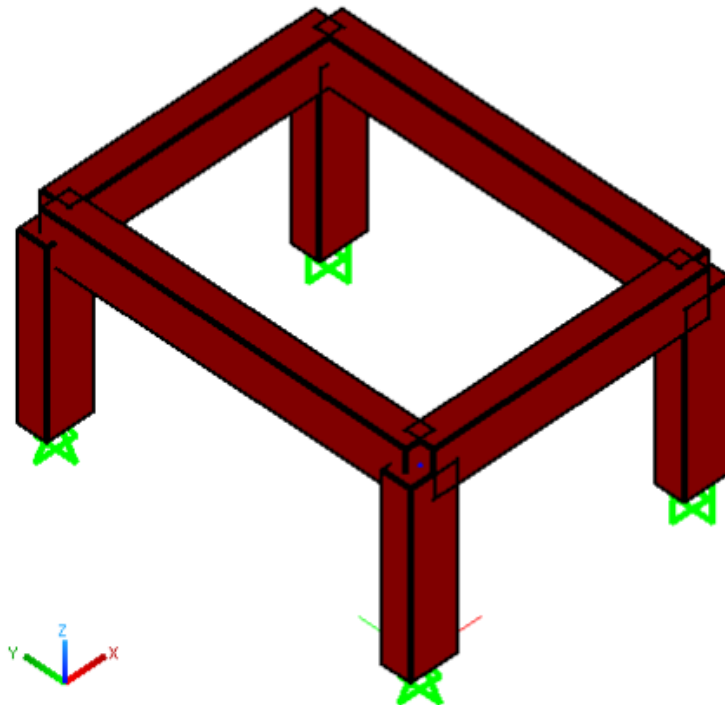

⚠ Only flexural deformations are considered.

- Units: kN for forces and m for lengths.

- Material Properties:
 - o Name: GL24H;
 - o $E=9.40e+6$ kN/m²;
 - o $\nu=0.3$
 - o Weight=3.8 kN/m³;
 - o Mass=0 kN/m³/g
- Section properties:
 - o B=300 mm (y direction);
 - o H=500 mm (z direction);
- Geometric properties:
 - o Lx=3 m;
 - o Ly=4m;
 - o Lz=2m;
- Mass properties: at every nodes of the 1st storey
 - o $m_y=2.5$ kN/g;
 - o $m_z=-2.5$ kN/g;
 - o $m_x=-2.5$ kN/g

- NextFEM Designer's Results:

- o First mode:

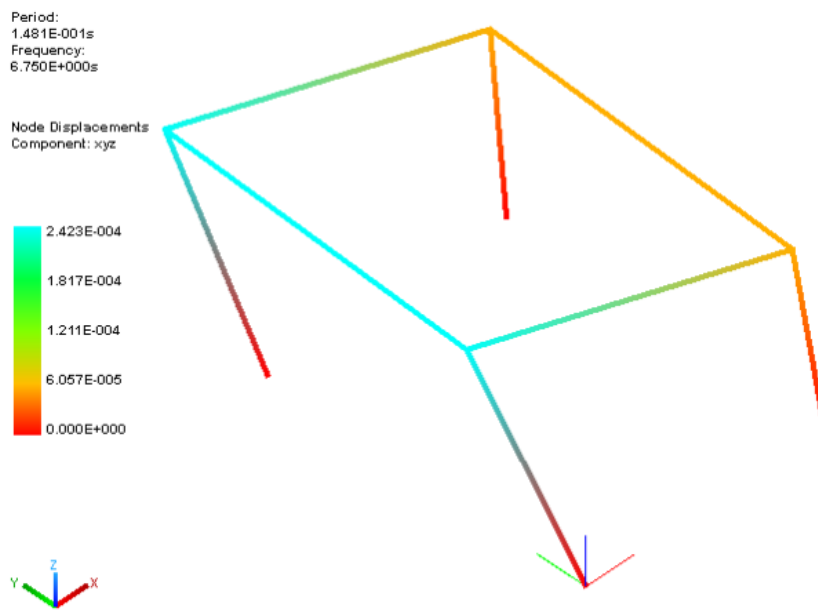

- o Second mode:

Period:
8.376E-002s
Frequency:
1.194E+001s

Node Displacements
Component: xyz

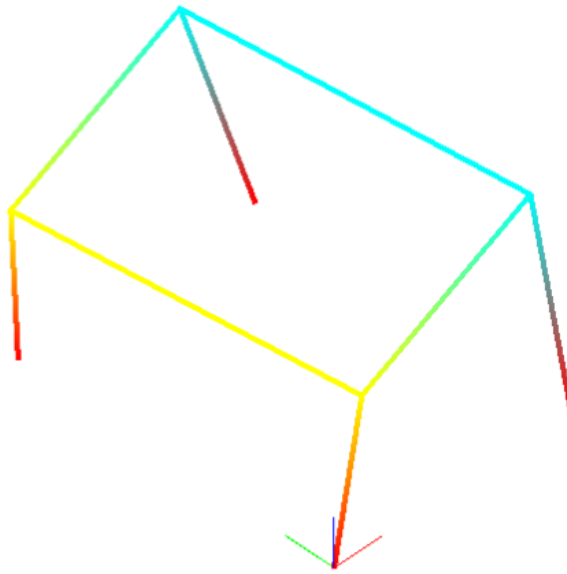
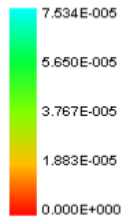

o Third mode:

Period:
7.794E-002s
Frequency:
1.283E+001s

Node Displacements
Component: xyz

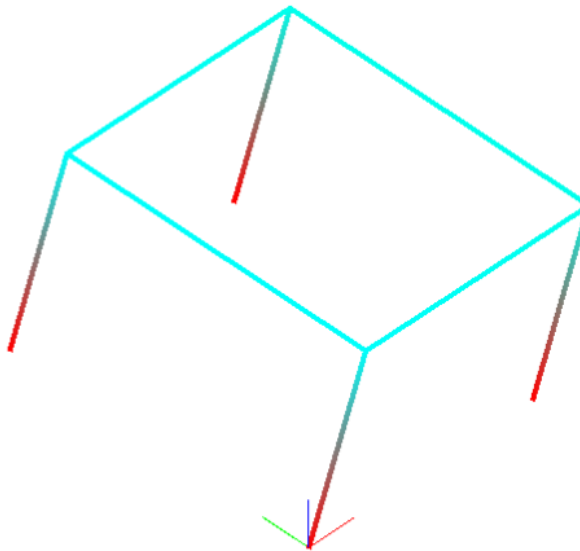
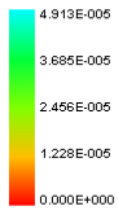

- SAP2000® results:

o First mode:

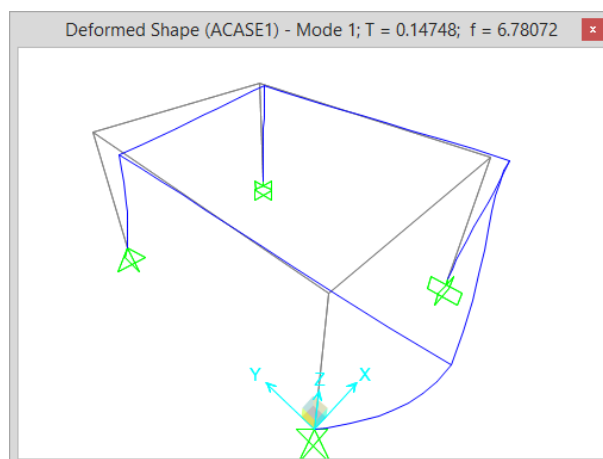

o Second mode:

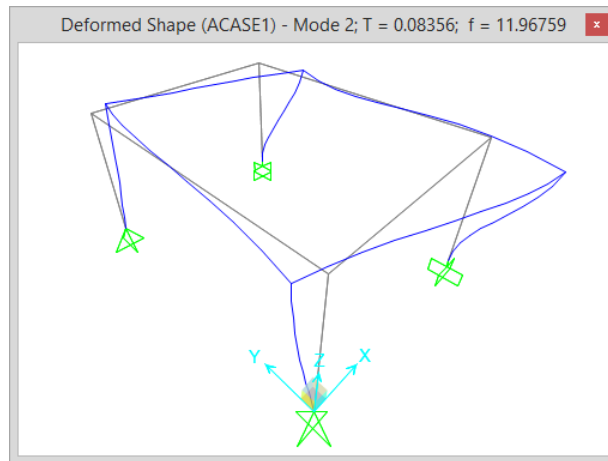

o Third mode:

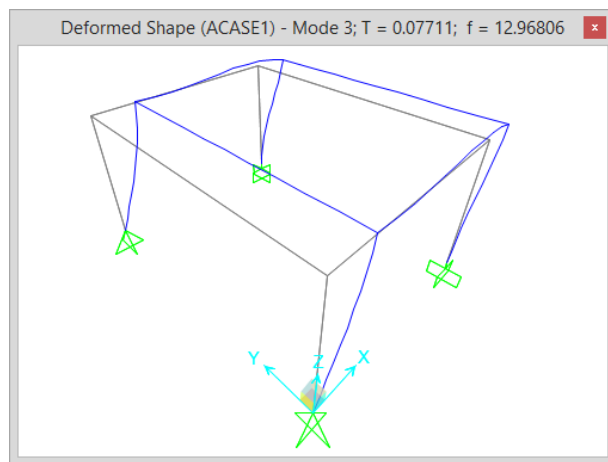

The test model, calculated with two different programs, shows the same results.

Tutorial Six

The sixth tutorial consists in a buckling analysis of a simply supported concrete column. The output of NextFEM Designer (i.e. the eigenvalues representing the load multipliers) is compared with the results computed by the Eulerian instability theory. The column is meshed into 5 elements of equal length.

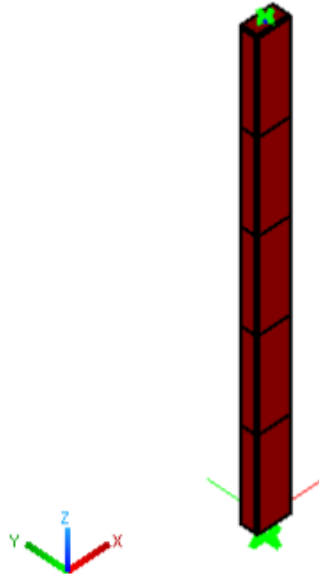

⚠ Only flexural deformations are considered.

- Units: kN for forces and m for lengths.
- Material Properties:
 - o Name: C25/30;
 - o $E=3.15e+6$ kN/m²;
 - o $\nu=0.2$
 - o Weight =25 kN/m³;
 - o Mass =2.5 kN/m³/g
- Section properties:
 - o B=100 mm (z);
 - o H=200 mm (y);
- Geometric properties:
 - o Ltot=3.0 m;
- Loads:
 - o Qz=-1 kN;

- NextFEM Designer's results:
 - o First mode:

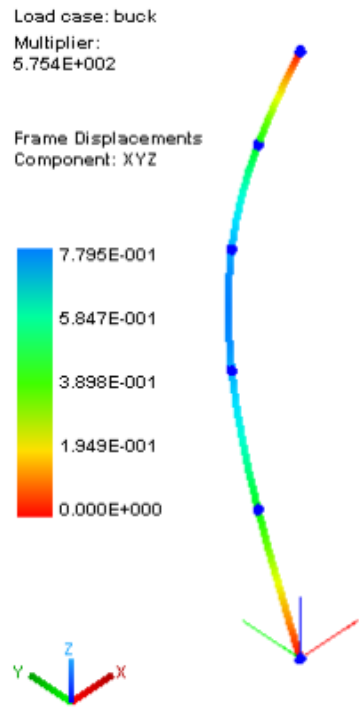

o Second mode:

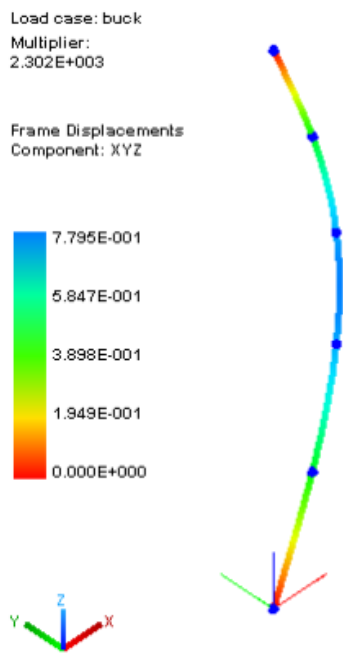

o Third mode:

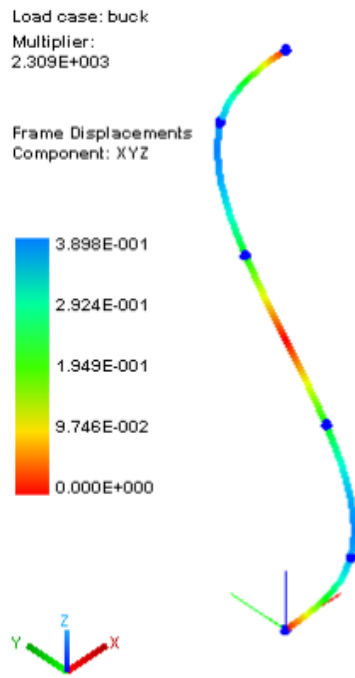

o Fourth mode:

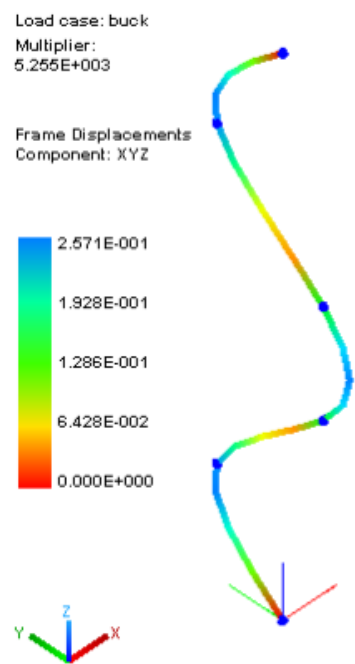

o Fifth mode:

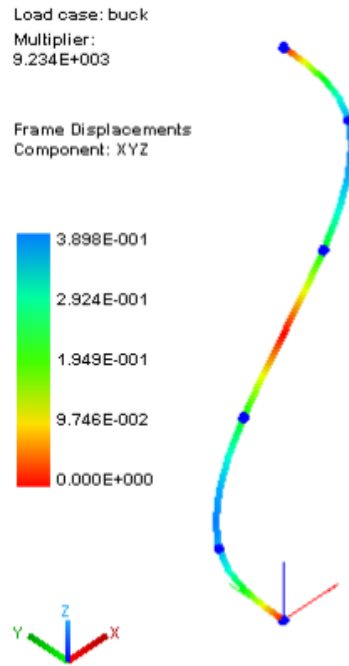

- Manual calculation:

- o The critical load is computed as come $P_{cr} = \pi^2 \frac{EJ}{(l/n)^2}$ with $n = 1, 2, 3, \dots$ and the inertia J of the direction of inflection.
- o Section inertia:

$$J_{yy} = \frac{1}{12} hb^3 = 16.7 \cdot 10^6 \text{ mm}^4$$

$$J_{zz} = \frac{1}{12} bh^3 = 66.7 \cdot 10^6 \text{ mm}^4$$

- o Theoretical results:

Bending around yy	Bending around zz
$\pi^2 \frac{EJ_{yy}}{l^2} = 575 \text{ kN}, \lambda = 575$	$\pi^2 \frac{EJ_{zz}}{l^2} = 2301 \text{ kN}, \lambda = 2301$
$\pi^2 \frac{EJ_{yy}}{(l/2)^2} = 2301 \text{ kN}, \lambda = 2301$	$\pi^2 \frac{EJ_{zz}}{(l/2)^2} = 9206 \text{ kN}, \lambda = 9206$
$\pi^2 \frac{EJ_{yy}}{(l/3)^2} = 5178 \text{ kN}, \lambda = 5178$	

NextFEM Designer's results are in agreement with the theoretical results.

Chapter 3

Verifications for steel members

In this chapter, all the verifications performed by *NextFEM Designer* for steel beams/trusses are described.

Symbols

A: Area

J_z : Moment of inertia around x-axis

J_y : Moment of inertia around y-axis

J_{min} : Minimum moment of inertia

J_t : Torsional Inertia

D: Diameter of circular cross sections

D_i : Inner diameter of pipe cross sections

t_e : Thickness of pipe cross sections

b: Base for any other cross sections

h: Height for any other cross sections

t_w : web thickness

t_{f1} : thickness of bottom flange

t_{f2} : thickness of upper flange

t: thickness for planar sections

N: Axial force

V_y : Shear force along y direction

V_z : Shear force along z direction

M_t : Twisting moment

M_{yy} : Moment around y local axis

M_{zz} : Moment around z local axis

E_m : material Young modulus

G_m : material shear modulus

ν_m : **material Poisson's ratio**

f_k : material characteristic strength

W_{elZ} : section modulus for Z axis

W_{elY} : section modulus for Y axis

W_{plZ} : plastic section modulus for Z axis

W_{plY} : plastic section modulus for Y axis

i_z : radius of inertia for Z axis

i_y : radius of inertia for Y axis

i_{min} : minimum radius of inertia

SecType: 1=beam, 2=planar, 0=unknown

SecBeamType: 0=unknown, 1=rectangular, 2=circular, 3=Cshape, 4=Tshape, 5=DoubleTshape, 6=Lshape, 7=box, 8=pipe

dx: axial relative displacement along beam axis

dy: transversal deflection in local direction y

dz: transversal deflection in local direction z.

Verification listing

Verifications performed by *NextFEM Designer* for steel beams/trusses are described afterwards. Each of them is expressed in terms of usage ratios of the checked section/element:

$$\rho = \frac{E_d}{R_d} = \frac{E_d}{\frac{R_k}{\gamma_M}}$$

with E_d design force

R_d is the design strength, equal to $\frac{R_k}{\gamma_M}$

R_k is the material characteristic strength

γ_M is the partial safety factor the material.

 WARNING: all the verifications listed do not support Class 4 transversal sections.

Estimation of section class

Conservatively, each section class is estimated as the maximum section class amongst the ones related to each part of the section, considered as fully in compression.

Section type	Parte	Ratio	Class 1	Class 2	Class 3
Rectangular		/			<i>always</i>
Double T, T, C	web	0.9(h-tf1)/tw	33ε	38ε	42ε
	flange	0.9(b/2-tw)/tf1	9ε	10ε	14ε
Angular	web	h _{max} /te			15ε
	flange	(b+h)/(2te)			11.5ε
Box	web	(h-2te)/te	9ε	10ε	14ε
	flange	(b-2te)/te	9ε	10ε	14ε
Pipe		D/te	50ε ²	70ε ²	90ε ²
Bar		/		<i>always</i>	
Generic		/			<i>always</i>

with $\varepsilon = \sqrt{\frac{235}{f_y}}$

The column name of the program output is reported between brackets (i.e. *(EulerBuckling)*)

Tension/compression (Axial)

In tension:

$$\rho_N = \frac{N}{N_{Rd}} = \frac{N}{\frac{Af_{yk}}{\gamma_{M0}}}$$

In compression (Eulerian buckling):

$$\rho_{Nb} = \frac{N}{N_{b,Rd}} = \frac{N}{\frac{\chi_{\min} A f_{yk}}{\gamma_{M1}}}$$

with χ_{\min} calculated on the base of the following buckling coefficients, determined for rolled sections only:

Section type	α_y	α_z	α_{LT}
Rectangular	0.49	0.49	0.76
Double T, I	da 0.21 a 0.76	da 0.21 a 0.76	da 0.34 a 0.49
Angular, C, T	0.49	0.49	0.76
Box	0.49	0.49	0.76
Pipe	0.49	0.49	0.76
Bar	0.49	0.49	0.76
Generic	-	-	-

Shear (Shear)

$$\rho_V = \frac{V}{V_{Rd}} = \frac{V}{\frac{A f_{yk}}{\gamma_{M0} \sqrt{3}}}$$

Bending with shear interaction (Bending)

$$\rho_{Mrid} = \frac{M}{\alpha_{PL} \cdot W \cdot f_{yk} \cdot \cos(\rho_N)} = \frac{M}{M_{Rd} \cdot \cos(\rho_N)} \quad \text{if the shear force does not exceed the 30\% of plastic strength;}$$

$$\rho_{Mrid} = \frac{M}{M_{Rd,red}}, \quad \text{with } M_{Rd,red} = M_{Rd} \left(1 - \min\left((2\rho_V - 1)^2, 1\right)\right) \quad \text{if the shear force exceeds the 50\% of plastic strength, } M_{Rd,red} = M_{Rd} \text{ otherwise.}$$

Biaxial bending and axial load (BuckBending_biax and TensBending_biax)

If the element is compressed:

$$\rho_{MNb} = \frac{\rho_N}{\chi_{\min}} + \frac{\rho_{M_y}}{r_{ridN_{cr}}} + \frac{\rho_{M_z}}{r_{ridN_{cr}}} \quad \text{with } r_{ridN_{cr}} = 1 - \frac{\rho_N \bar{\lambda}^2}{\gamma_{M0}}$$

If the element is tensioned:

$$\rho_{MNb} = \rho_N + \rho_{M_y} + \rho_{M_z}$$

Torsional buckling (TorsionBuckling)

 **WARNING:** this check is not performed for pipe sections in a scaffolding.

$$\rho_{MTb} = \frac{M}{M_{b,Rd}} = \frac{M}{\frac{\chi_{LT} A \cdot W_{pl} \cdot f_k}{\gamma_{M1}}}$$

For torsional buckling, the second-order twisting moment (Vlasov's contribution) is always neglected:

$$M_{cr} = \psi \frac{\pi}{L_{0b}} \sqrt{EI_y \cdot GI_T} \sqrt{1 + \left(\frac{\pi}{L_{0b}}\right)^2 \cdot \frac{EI_\omega}{GI_T}} \quad \text{con } I_\omega = 0$$

except for the following sections:

- double T, I: $I_\omega = \frac{(h - t_f)^2}{4} I_y$
- C-shaped: $I_\omega = \frac{(h - t_f)^2 \cdot b^3 \cdot t_f}{12} \cdot \frac{2F + 3}{F + 6}$ with $F = \frac{h - t_f}{b}$

In evaluating the critical resisting moment, the coefficient ψ is forced to the value 1.127 if the beam has null moments at both ends. In any case, it is limited to 1.285.

Combined torsional buckling (*TorsionBuck_comb*)

$$\rho_{MNb} = \frac{\rho_N}{\chi_{\min}} + \frac{\rho_{M_y}}{\chi_{LT} \cdot r_{ridN_{cr}}} + \frac{\rho_{M_z}}{r_{ridN_{cr}}} \quad \text{and} \quad \rho_{MNb} = \frac{\rho_N}{\chi_{\min}} + \frac{\rho_{M_y}}{r_{ridN_{cr}}} + \frac{\rho_{M_z}}{\chi_{LT} \cdot r_{ridN_{cr}}} \quad (\text{for rotated sections})$$

Deflection checks

Deflection checks (*Deflection*)

$$\rho_f = \frac{\sqrt{f_y^2 + f_z^2}}{defLimit}$$

⚠ WARNING: *defLimit* is defined in the initial mask for steel checking, separately for beams and columns. By default, values are set to 1/250 for beams (*defTR*) and 1/300 for columns (*defCOL*).

# Steel checking as per Eurocode 3	
Maximum beam deformation	
defTR	1/250
Maximum column deformation	
defCOL	1/300

Checking from pushover analysis

Non-linear static analysis (pushover) needs a global check (performed in ADRS plane by the mash *Extract Data*) and local verifications, carried-out for each element, for brittle (shear) and ductile (flexure) mechanism.

Firstly, for steel structures, it is necessary to globally check the structure with the command *N2 Method* from inside *Extract Data* window, at the item *Base shear X/Y VS Top displX/Y*. Once the performance point has been determined, and hence the displacement demand is known, the closest point of the curve will be used. In such point, local checking will be performed for brittle and ductile mechanisms, directly on data supplied by hinges.

The image shows two windows from a structural analysis software. The top window is titled 'Extract data from results' and contains several panels. On the left, there are dropdown menus for 'Select load case or step' (set to 'pushoverX') and 'Select time or mode' (set to '1.2706654'). The 'Select data type' panel has 'Base shearX VS Top displX' selected. A table in the center shows parameters: Time/Mode (2-X), Displacement (m*), and Value (1.010E+002). On the right, an 'ADRS' plot shows Sa [m/s^2] vs. T, with a performance point labeled 'PP(5.684e-2, 2.2.335e0)'. The bottom window is titled 'Verification' and shows 'Checking settings' for 'Element results' on 'pushoverX' at time '1.2706654'. It is configured for 'I and J only' stations and 'Steel Hinge EC3' built-in checking. A table of 'Limit State OLS 1-DLS 2-LLS 3-CLS 4' shows 'SL' set to '3'. The 'Run checking' section has 'Perform checks' and 'Export table...' buttons. A table on the right lists results for class '06654' with columns for Axial, Shear, FlexCapacityY, and FlexCapacityZ. The 'Output accuracy' is set to '0.000'.

To conduct the verifications, inside the Verification mask, select in order:

- The pushover load case
- "I and J only" as active stations
- The checking set "Steel Hinge EC3"
- The reference Limit State. Life-safety is default
- Optionally, increase the accuracy of table results, to highlight even the lowest Demand/Capacity ratios.

If the global checking has been conducted correctly, the “time/mode” menu is automatically switched to time corresponding to the selected point on pushover curve representing the displacement demand (in the picture above, $t=1.2706$).

For steel structures, the verifications report:

- The ratio between the shear force and the strength, for both local directions y and z;
- The ration between the hinge rotation and the allowable chord rotation related to each single element.

Limit State	Class	
	1	2 or higher
OLS	$2/3 \vartheta_y$	$1/6 \vartheta_y$
DLS	ϑ_y	$1/4 \vartheta_y$
LLS	$6 \vartheta_y$	$2 \vartheta_y$
CLS	$8 \vartheta_y$	$3 \vartheta_y$

with $\vartheta_y = \frac{M_{el}L_v}{2EJ}$

where M_{el} is the elastic resisting moment, L_v is the contra-flexure span, E is Young’s modulus and J the inertia in the proper direction.

Chapter 4

Verifications for aluminium members

In this chapter, all the verifications performed by *NextFEM Designer* for aluminium beams/trusses are described. Such verification contains references to EN 1999-1-1 (Eurocode 9).

Symbols

- A: Area
- J_z : Moment of inertia around x-axis
- J_y : Moment of inertia around y-axis
- J_{min} : Minimum moment of inertia
- J_t : Torsional Inertia
- D: Diameter of circular cross sections
- D_i : Inner diameter of pipe cross sections
- t_e : Thickness of pipe cross sections
- b: Base for any other cross sections
- h: Height for any other cross sections
- t_w : web thickness
- t_{f1} : thickness of bottom flange
- t_{f2} : thickness of upper flange
- t: thickness for planar sections
- N: Axial force
- V_y : Shear force along y direction
- V_z : Shear force along z direction
- M_t : Twisting moment
- M_{yy} : Moment around y local axis
- M_{zz} : Moment around z local axis
- E_m : material Young modulus
- G_m : material shear modulus
- ν_m : **material Poisson's ratio**
- f_k : material characteristic strength
- W_{elZ} : section modulus for Z axis
- W_{elY} : section modulus for Y axis
- W_{plZ} : plastic section modulus for Z axis
- W_{plY} : plastic section modulus for Y axis
- i_z : radius of inertia for Z axis
- i_y : radius of inertia for Y axis
- i_{min} : minimum radius of inertia
- SecType: 1=beam, 2=planar, 0=unknown
- SecBeamType: 0=unknown, 1=rectangular, 2=circular, 3=Cshape, 4=Tshape, 5=DoubleTshape, 6=Lspahe, 7=box, 8=pipe

- dx: axial relative displacement along beam axis
- dy: transversal deflection in local direction y
- dz: transversal deflection in local direction z.

Verification listing

Verifications performed by *NextFEM Designer* for aluminium beams/trusses are described afterwards. Each of them is expressed in terms of usage ratios of the checked section/element:

$$\rho = \frac{E_d}{R_d} = \frac{E_d}{\frac{R_k}{\gamma_M}}$$

with E_d design force

R_d is the design strength, equal to $\frac{R_k}{\gamma_M}$

R_k is the material characteristic strength

γ_M is the partial safety factor the material.

 WARNING: all the verifications listed do not support Class 4 transversal sections.

 WARNING: Inside the program, the material library *Alloy* lists the most spread aluminium alloys. Pay attention to the material names, which may include some limitations for particular section shapes:

SH - Sheet (EN 485)

ST - Strip (EN 485)

PL - Plate (EN 485)

ET - Extruded Tube (EN 755)

EP - Extruded Profiles (EN 755)

ER/B - Extruded Rod and Bar (EN 755)

DT - Drawn Tube (EN 754)

FO - Forgings (EN 586)

Estimation of section class

Conservatively, each section class is estimated as the maximum section class amongst the ones related to each part of the section, considered as fully in compression (t_e signifies section thickness).

Section type	Part	Ratio	Class 1	Class 2	Class 3
Rectangular		/			<i>always</i>
Double T, T, C	web	$0.9(h-tf1)/t_w$	β_1	β_2	β_3
	flange	$0.9(b/2-t_w)/t_{f1}$	β_1	β_2	β_3
Angular	web	h_{max}/t_e			β_3
	flange	$(b+h)/(2t_e)$			β_3
Box	web	$(h-2t_e)/t_e$	β_1	β_2	β_3
	flange	$(b-2t_e)/t_e$	β_1	β_2	β_3
Pipe		$3\sqrt{D/t_e}$	β_1	β_2	β_3
Bar		/		<i>always</i>	
Generic		/			<i>always</i>

The values β_1 , β_2 , β_3 are computed automatically by considering the ratios β/ε reported on the following table and multiplied by the parameter ε defined as follows:

$$\varepsilon = \sqrt{\frac{250}{f_0}}$$

For the flanges in a section, the coefficients for the outstand parts are used; for webs and sides of a section, the coefficients for the internal parts are employed.

The design codes provide different coefficients for welded and non-welded sections. Coefficients for non-welded sections are taken by default, but it is possible to enforce the variable *welded*=1 before to start the checking, to force the procedure to assume all the sections as welded. To force the checking for welded material ONLY at beam ends, set the variable *weldedEnds*=1.

⚠ WARNING: for the welded section checking, the verification procedure uses the value of *f0HAZ* from the *Alloy material library*. In the case a custom material is used, please add the line "*f0HAZ=xxx*" in the textbox inside the *Verification* mask, with *f0HAZ* in MPa.

	Durability class	Internal part			Outstand part		
		β_1/ε	β_2/ε	β_3/ε	β_1/ε	β_2/ε	β_3/ε
w/o welds	A	12.44	16	22	4	4.5	6
	B	12.44	16	20	4	4.5	5.5
	C	12.44	16	18	4	4.5	5
with welds	A	9.95	13	18	3.2	4	5
	B	9.95	13	16.5	3.2	3.8	4.5
	C	9.95	13	15	3.2	3.5	4

The column name of the program output is reported between brackets (i.e. (*EulerBuckling*)). In the following formula, *f0* (or *f0HAZ*) is written as *fyk*.

Tension/compression (Axial)

In tension:

$$\rho_N = \frac{N}{N_{Rd}} = \frac{N}{\frac{A f_{yk}}{\gamma_{M0}}}$$

In compression (Eulerian buckling):

$$\rho_{Nb} = \frac{N}{N_{b,Rd}} = \frac{N}{\frac{\chi_{\min} A f_{yk}}{\gamma_{M1}}}$$

with χ_{\min} calculated on the base of the buckling coefficients, determined from chapter 8.5 in Eurocode 9.

Shear (Shear)

$$\rho_V = \frac{V}{V_{Rd}} = \frac{V}{\frac{A f_{yk}}{\gamma_{M0} \sqrt{3}}}$$

Bending with shear interaction (Bending)

$\rho_{Mrid} = \frac{M}{\alpha_{PL} \cdot W \cdot f_{yk} \cdot \cos(\rho_N)} = \frac{M}{M_{Rd} \cdot \cos(\rho_N)}$ if the shear force does not exceed the 30% of plastic strength;

$\rho_{Mrid} = \frac{M}{M_{Rd,red}}$, with $M_{Rd,red} = M_{Rd} \left(1 - \min((2\rho_V - 1)^2, 1)\right)$ if the shear force exceeds the 50% of plastic strength, $M_{Rd,red} = M_{Rd}$ otherwise.

Biaxial bending and axial load (BuckBending_biax and TensBending_biax)

If the element is compressed:

$$\rho_{MNB} = \frac{\rho_N}{\chi_{min}} + \frac{\rho_{M_y}}{r_{ridN_{cr}}} + \frac{\rho_{M_z}}{r_{ridN_{cr}}} \text{ with } r_{ridN_{cr}} = 1 - \frac{\rho_N \bar{\lambda}^2}{\gamma_{M0}}$$

If the element is tensioned:

$$\rho_{MNB} = \rho_N + \rho_{M_y} + \rho_{M_z}$$

Torsional buckling (TorsionBuckling)

⚠ WARNING: this check is not performed for pipe sections in a scaffolding.

$$\rho_{MTb} = \frac{M}{M_{b,Rd}} = \frac{M}{\frac{\chi_{LT} A \cdot W_{pl} \cdot f_k}{\gamma_{M1}}}$$

For torsional buckling, the second-order twisting moment (Vlasov's contribution) is always neglected:

$$M_{cr} = \psi \frac{\pi}{L_{0b}} \sqrt{EI_y \cdot GI_T} \sqrt{1 + \left(\frac{\pi}{L_{0b}}\right)^2 \cdot \frac{EI_\omega}{GI_T}} \quad \text{con } I_\omega = 0$$

except for the following sections:

- double T, I: $I_\omega = \frac{(h - t_f)^2}{4} I_y$
- C-shaped: $I_\omega = \frac{(h - t_f)^2 \cdot b^3 \cdot t_f}{12} \cdot \frac{2F + 3}{F + 6}$ with $F = \frac{h - t_f}{b}$.

In evaluating the critical resisting moment, the coefficient ψ is forced to the value 1.127 if the beam has null moments at both ends. In any case, it is limited to 1.285. The values for the proper instability curves are taken from chapter 8.5 of Eurocode 9.

Combined torsional buckling (TorsionBuck_comb)

$$\rho_{MNb} = \frac{\rho_N}{\chi_{\min}} + \frac{\rho_{M_y}}{\chi_{LT} \cdot r_{ridN_{cr}}} + \frac{\rho_{M_z}}{r_{ridN_{cr}}} \quad \text{and} \quad \rho_{MNb} = \frac{\rho_N}{\chi_{\min}} + \frac{\rho_{M_y}}{r_{ridN_{cr}}} + \frac{\rho_{M_z}}{\chi_{LT} \cdot r_{ridN_{cr}}} \quad (\text{for rotated sections})$$

Deflection checks

Deflection checks (Deflection)

$$\rho_f = \frac{\sqrt{f_y^2 + f_z^2}}{defLimit}$$

! WARNING: *defLimit* is defined in the initial mask for steel checking, separately for beams and columns. By default, values are set to 1/250 for beams (*defTR*) and 1/300 for columns (*defCOL*).

Alloy checking as per EC9

Maximum beam deformation	
defTR	1/250
Maximum column deformation	
defCOL	1/300
Welded sections [0/1]	
welded	0
Welded ends [0/1]	
weldedEnds	0

Chapter 5

Verifications for reinforced concrete members

In this chapter, all the verifications performed by *NextFEM Designer* for reinforced concrete beams and walls are described.

Symbols

A: Area

Jz: Moment of inertia around x-axis

Jy: Moment of inertia around y-axis

Jmin: Minimum moment of inertia

Jt: Torsional Inertia

D: Diameter of circular cross sections

Di: Inner diameter of pipe cross sections

te: Thickness of pipe cross sections

b: Base for any other cross sections

h: Height for any other cross sections

tw: web thickness

tf1: thickness of bottom flange

tf2: thickness of upper flange

t: thickness for planar sections

N: Axial force

Vy: Shear force along y direction

Vz: Shear force along z direction

Mt: Twisting moment

Myy: Moment around y local axis

Mzz: Moment around z local axis

Em: material Young modulus

Gm: material shear modulus

Nlm: material Poisson's ratio

fk: material characteristic strength

WelZ: section modulus for Z axis

WelY: section modulus for Y axis

WplZ: plastic section modulus for Z axis

WplY: plastic section modulus for Y axis

iz: radius of inertia for Z axis

iy: radius of inertia for Y axis

imin: minimum radius of inertia

SecType: 1=beam, 2=planar, 0=unknown

SecBeamType: 0=unknown, 1=rectangular, 2=circular, 3=Cshape, 4=Tshape, 5=DoubleTshape, 6=Lspahe, 7=box, 8=pipe

dx: axial relative displacement along beam axis

dy: transversal deflection in local direction y

dz: transversal deflection in local direction z

bwY: minimum section width in local direction y

bwZ: minimum section width in local direction z

ds: effective depth of the section

Astot: total area of rebar for a section

AsTens: total area of rebar in tension

fyks: characteristic strength for stirrups

fydl: design strength for longitudinal bars
 rebCmin: distanza minima fra bordo e centro armatura longitudinale
 isWall: equal to 1 if the section belongs to a wall, 0 otherwise
 AmbCondition: environmental conditions for serviceability check (1,2,3)
 mNt: ductility in tension for plastic hinges
 mNc: ductility in compression for plastic hinges
 mVy: ductility in shear (local direction y) for plastic hinges
 mVz: ductility in shear (local direction z) for plastic hinges
 mMt: torsional ductility for plastic hinges
 mMy: flexural ductility (around local axis y) for plastic hinges
 mMz: flexural ductility (around local axis z) for plastic hinges
 NbH: maximum compressive strength for plastic hinges
 MTH: elastic torsional strength for plastic hinges.

Verification listing

Verifications performed by *NextFEM Designer* for aluminium beams/trusses are described afterwards. Each of them is expressed in terms of usage ratios of the checked section/element:

$$\rho = \frac{E_d}{R_d} = \frac{E_d}{\frac{R_k}{\gamma_M}}$$

with E_d design force

R_d is the design strength, equal to $\frac{R_k}{\gamma_M}$

R_k is the material characteristic strength

γ_M is the partial safety factor the material.

 WARNING: all the verifications cover static combinations only. Seismic verifications of reinforced concrete members are not yet supported.

Ultimate Limit States

Stability in compression

$$\rho_{slend} = \frac{\max\left(\frac{L_{0y}}{i_y}, \frac{L_{0z}}{i_z}\right)}{25} \cdot \sqrt{\frac{|N|}{A \cdot f_{cd}}}$$

Shear for members without shear reinforcement

For each local direction y and z:

$$V_{rd} = \max \left\{ \left[\frac{0.18}{\gamma_m} \cdot k \cdot (100 \rho_l \cdot f_{ck})^{\frac{1}{3}} + 0.15 \sigma_{cp} \right] b_w \cdot ds, \left(v_{\min} + 0.15 \sigma_{cp} \right) b_w \cdot ds \right\}$$

with

$$k = 1 + \sqrt{\frac{200}{ds}} \leq 2 \quad v_{\min} = 0.035k^{1.5} f_{ck}^{0.5} \quad \rho_l = \frac{A_{sl}}{b_w \cdot ds} \quad \sigma_{cp} = \min\left(\frac{N}{A_{cls}}, 0.2 f_{cd}\right)$$

Shear for members with shear reinforcement

$$V_{Rsd} = 0.9d \frac{A_{sw}}{s} f_{yd} (\cot \alpha + \cot \theta) \sin \alpha$$

$$V_{Rcd} = 0.9d \cdot b_w \cdot \alpha_{cw} \cdot 0.5 f_{cd} \frac{(\cot \alpha + \cot \theta)}{(1 + \cot^2 \theta)}$$

$$V_{Rd} = \min(V_{Rsd}, V_{Rcd})$$

Note 3: The recommended value of α_{cw} is as follows:

1 for non-prestressed structures

$(1 + \sigma_{cp}/f_{cd})$ for $0 < \sigma_{cp} \leq 0,25 f_{cd}$

(6.11.aN)

1,25 for $0,25 f_{cd} < \sigma_{cp} \leq 0,5 f_{cd}$

(6.11.bN)

$2,5 (1 - \sigma_{cp}/f_{cd})$ for $0,5 f_{cd} < \sigma_{cp} < 1,0 f_{cd}$

(6.11.cN)

where:

σ_{cp} is the mean compressive stress, measured positive, in the concrete due to the design axial force.

Torsion

The value of $\cot \theta$ is assumed as the minimum between the 2 local directions y and z.

$$T_{Rcd} = 2A \cdot t_t \cdot \alpha_{cw} \cdot 0.5 f_{cd} \cdot \frac{\cot \theta}{(1 + \cot^2 \theta)} \quad \text{con } t_t = \max\left(\frac{A}{per}, 2 \cdot rebCmin\right)$$

$$T_{Rld} = 2A \frac{A_{stot}}{per - \pi \cdot t_t} \cdot \frac{f_{ydl}}{\cot \theta}$$

$$T_{Rd} = \min(T_{Rcd}, T_{Rld})$$

Shear and torsion

The ratio for shear forces is the maximum between the 2 local directions y and z.

$$\frac{T_{Ed}}{T_{Rd}} + \frac{V_{Ed}}{V_{Rd}} \leq 1$$

Serviceability Limit States

Cracking

Given the exposure class of concrete, the variable *AmbCondition* can be set as:

- 1 for normal conditions (X0, XC1, XC2, XC3, XF1),
- 2 for aggressive conditions (XC4, XD1, XS1, XF2) and
- 3 for extremely aggressive environmental conditions.

Table 7.1N Recommended values of w_{max} (mm)

Exposure Class	Reinforced members and prestressed members with unbonded tendons	Prestressed members with bonded tendons
	Quasi-permanent load combination	Frequent load combination
X0, XC1	0,4 ¹	0,2
XC2, XC3, XC4	0,3	0,2 ²
XD1, XD2, XS1, XS2, XS3		Decompression
<p>Note 1: For X0, XC1 exposure classes, crack width has no influence on durability and this limit is set to guarantee acceptable appearance. In the absence of appearance conditions this limit may be relaxed.</p> <p>Note 2: For these exposure classes, in addition, decompression should be checked under the quasi-permanent combination of loads.</p>		

Environmental condition is needed for cracking control. The verification is performed without direct calculation using the following tables.

Table 7.2N Maximum bar diameters ϕ_s^* for crack control¹

Steel stress ² [MPa]	Maximum bar size [mm]		
	$w_k = 0,4$ mm	$w_k = 0,3$ mm	$w_k = 0,2$ mm
160	40	32	25
200	32	25	16
240	20	16	12
280	16	12	8
320	12	10	6
360	10	8	5
400	8	6	4
450	6	5	-

Table 7.3N Maximum bar spacing for crack control¹

Steel stress ² [MPa]	Maximum bar spacing [mm]		
	$w_k = 0,4$ mm	$w_k = 0,3$ mm	$w_k = 0,2$ mm
160	300	300	200
200	300	250	150
240	250	200	100
280	200	150	50
320	150	100	-
360	100	50	-

The maximum diameter values obtained in this way are corrected on the base of their material and their stress state using the following relationships.

Bending (at least part of section in compression):

$$\phi_s = \phi_s^* (f_{ct,eff}/2,9) \frac{k_c h_{cr}}{2 (h-d)} \quad (7.6N)$$

Tension (uniform axial tension)

$$\phi_s = \phi_s^* (f_{ct,eff}/2,9) h_{cr}/(8(h-d)) \quad (7.7N)$$

The computed quantities are:

$$rebarDiameterRatio = \max \left(\frac{\phi_i}{\phi_{s,i}} \right) \text{ for each rebar } i$$

$$rebarSpacingRatio = \max \left(\frac{s_i}{s_{s,i}} \right) \text{ for each rebar } i$$

While the final value used for verification is

$$cracking = \max (rebarDiameterRatio, rebarSpacingRatio).$$

Deflection control

Beams limit deflection can be chosen by the user by setting the value *defTR*.

Checking is performed as follows:

$$defl = \sqrt{dy^2 + dz^2}$$

$$\rho_{Def} = \frac{defl}{L} \frac{1}{defTR}$$

Checking of Reinforced Concrete elements
as per Eurocode 2

Ambient condition	
AmbCondition	1
Maximum beam deformation	
defTR	1/250

Stress limitation

Stress control check for steel and concrete, for Characteristic and Quasi-Permanent combinations, are performed as follows:

$$\sigma_{limC} = 0.45 f_k, \sigma_{limS} = 0.6 f_k$$

$$\rho_{StressC} = |S_{maxCls}| / \sigma_{limC}$$

$$\rho_{StressS} = |S_{maxReb}| / \sigma_{limS}$$

Member detailing

Rebar area

The total compression and tension rebar areas are checked against the limit of $0.04 A_c$. Such control has a Boolean result.

Seismic design

Seismic checks are performed when the set name "Concrete EC" is selected. Such checking set contains all the verifications performed for static combinations and adds further prescriptions for seismic design of structures.

User must set:

- The ductility class: H=1, M=2. M is default, 3 for class M without nodes; 4 for static or non-dissipative check;
- For ductility checks: the behaviour factor q_0 , the corner period T_c of the design spectrum.

Concrete seismic checking as per NTC2018	
Ambient condition (1,2,3)	
AmbCondition	1
Maximum beam deformation	
defTR	0.004
Ductility Class (H:1,M:2,noNodes:3,static:4)	
CD	2
Behaviour factor	
q0	1.5
Design spectrum corner period Tc	

Geometric checks

$$b \geq 20 \text{ cm}$$

For beams: $\frac{b}{h} \geq 0.25$

For columns: $\min(b, h) \geq 25 \text{ cm}$

For walls: $t \geq 15 \text{ cm}$

Ductility checks

The ductility check is performed for sections of beams and columns inside the critical length. Ductility demand is evaluated as follows:

$$\mu_{\phi} = 2q_0 - 1 \quad \text{if } T_1 \geq T_C \quad (5.4)$$

$$\mu_{\phi} = 1 + 2(q_0 - 1)T_C/T_1 \quad \text{if } T_1 < T_C \quad (5.5)$$

Since the check is performed inside critical regions, such values are amplified by 1.5, as required by EC8-1-1 5.2.3.4 (4).

Shear

Inside critical regions, $ctg(\theta) = 1$. Shear force is recalculated as per capacity design.

Column compression ratio

$$\frac{N_{Ed}}{f_{cd} A_{cl}} \text{ with } crc = 0.55 \text{ for ductility class H, } 0.65 \text{ otherwise.}$$

crc

Beam-column joints

$$\frac{A_{sh} \cdot f_{ywd}}{b_j \cdot h_{jw}} \geq \frac{\left(\frac{V_{jhd}}{b_j \cdot h_{jc}} \right)^2}{f_{ctd} + v_d f_{cd}} - f_{ctd} \quad (5.35)$$

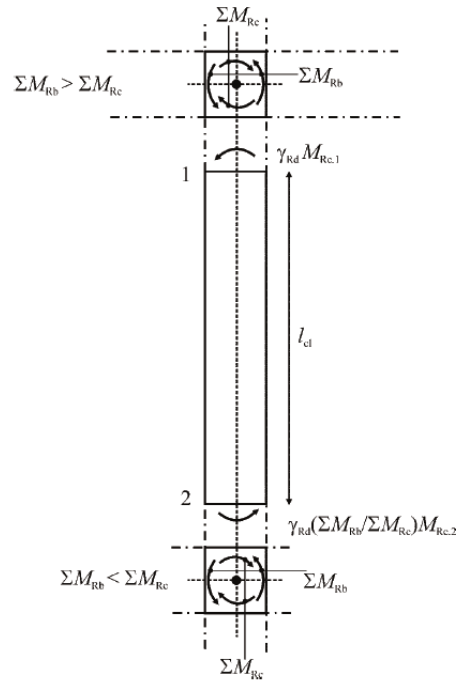

a) In interior joints:

$$A_{sh} f_{ywd} \geq \gamma_{Rd} (A_{s1} + A_{s2}) f_{yd} (1 - 0,8 v_d) \quad (5.36a)$$

b) In exterior joints:

$$A_{sh} f_{ywd} \geq \gamma_{Rd} A_{s2} f_{yd} (1 - 0,8 v_d) \quad (5.36b)$$

Capacity design

Bending:

$$M_{i,d} = \gamma_{Rd} M_{Rc,i} \min\left(1, \frac{\sum M_{Rb}}{\sum M_{Rc}}\right)$$

Shear:

$$V_{Ed} l_p = \gamma_{Rd} (M_{i,d}^s + M_{i,d}^i)$$

For beams, design shear force is evaluated as per the following scheme.

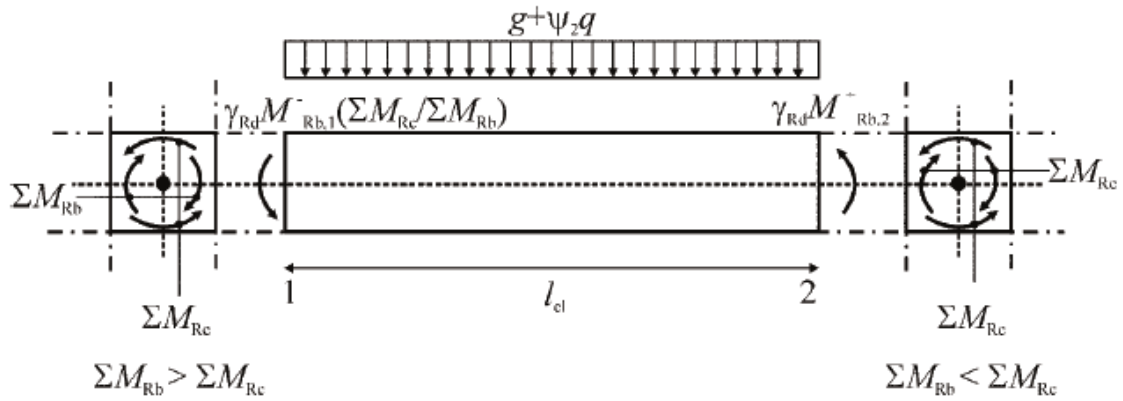

For walls, translation of M_z moment is performed for a length equal to hcr (critical height) and shear is amplified by the minimum of $q\theta$ and the inverse of bending check ratio.

The verification of the walls considers the increased shear (with the minimum at $V_y/2$ of station 1) and is carried out for:

- Shear-compression
- Shear-tension
- Sliding

The contributions of inclined reinforcement are not considered.

For reinforced concrete coupling beams, it is reported if the span-to-height ratio is less than 3 or if shear force in Y-direction is greater than:

$$\rho_{Vbeam} = \frac{V_y}{0.9l_w f_{ctd} t}$$

Detailing for beams

Longitudinal reinforcements (RebarArea)

$$\rho_{max} = \rho' + \frac{0,0018}{\mu_\phi \varepsilon_{sy,d}} \times \frac{f_{cd}}{f_{yd}} \quad (5.11)$$

$$\rho_{min} = 0,5 \left(\frac{f_{ctm}}{f_{yk}} \right) \quad (5.12)$$

Hoops diameters (StirrupDiam)

$$\frac{6}{D_{hoops,mm}}$$

Hoops spacing (StirrupSpac)

$$\frac{s}{\min\left(\frac{d}{4}, 175mm \text{ or } 225mm, 24D_{hoops}, 6D \text{ or } 8D\right)} \text{ depending on ductility class "H" or "M"}$$

Detailing for columns

Longitudinal reinforcements (RebarArea)

$$1\% \leq \rho \leq 4\%$$

Longitudinal rebars spacing (RebarDist)

$$\frac{\text{spacing}_{rebar}}{25cm}$$

Hoops diameters (StirrupDiam)

$$\frac{\max\left(6mm, 0.4D_{\max} \sqrt{\frac{f_{ydl}}{f_{ydst}}}\right) \text{ or } 6mm}{D_{hoops,mm}} \text{ depending on ductility class "H" or "M"}$$

Hoops spacing (StirrupSpac)

$$\frac{s}{\min(0.33 \min(b, h) \text{ or } 0.5 \min(b, h), 125mm \text{ or } 175mm, 6D \text{ or } 8D)} \text{ depending on ductility class "H" or "M"}$$

Shear verification in the plane for sliding walls (Sliding)

The resistance is the minimum between:

$$V_{dd} = \min \begin{cases} 1,3 \times \sum A_{sj} \times \sqrt{f_{cd} \times f_{yd}} \\ 0,25 \times f_{yd} \times \sum A_{sj} \end{cases} \quad (5.41)$$

$$V_{fd} = \min \begin{cases} \mu_t \times [(\sum A_{sj} \times f_{yd} + N_{Ed}) \times \xi + M_{Ed}/z] \\ 0,5 \eta \times f_{cd} \times \xi \times l_w \times b_{wo} \end{cases} \quad (5.43)$$

Checking FRP reinforcements

The verifications of the sections in c.a. reinforced with carbon fiber polymers (FRP) tapes are described below. The calculation procedure refers to the following Italian standards:

- CNR-DT 200 R1 / 2013 - Instructions for the Design, Execution and Control of Static Consolidation Interventions through the use of Fiber-reinforced Composites - Materials, reinforced concrete structures and of c.a.p., masonry structures;
- Guidelines for the Design, Execution and Testing of Reinforcement Interventions of reinforced concrete structures and masonry through FRP - Document approved on July 24, 2009 by the General Assembly of the Superior Council LL PP.

With reference to the CNR-DT200, the resistance of the FRP tape at the ultimate limit state is assumed to be the minimum between:

- Resistance due to detachment of ends, evaluated with the expression:

$$f_{\text{fdd}} = \frac{1}{\gamma_{\text{fd}}} \cdot \sqrt{\frac{2 \cdot E_f \cdot \Gamma_{\text{Fd}}}{t_f}}, \quad (4.4)$$

in which the specific fracture energy is evaluated as:

$$\Gamma_{\text{Fd}} = \frac{k_b \cdot k_G}{FC} \cdot \sqrt{f_{\text{cm}} \cdot f_{\text{ctm}}}. \quad (4.2)$$

- Resistance for intermediate detachment, evaluated as:

$$f_{\text{fdd},2} = \frac{k_q}{\gamma_{\text{fd}}} \cdot \sqrt{\frac{E_f}{t_f} \cdot \frac{2 \cdot k_b \cdot k_{G,2}}{FC} \cdot \sqrt{f_{\text{cm}} \cdot f_{\text{ctm}}}}, \quad (4.6)$$

also assuming an ultimate deformation equal to the minimum between the maximum declared by the manufacturer (multiplied by) and:

$$\varepsilon_{\text{fdd}} = \frac{f_{\text{fdd},2}}{E_f} \geq \varepsilon_{\text{sy}} - \varepsilon_0, \quad (4.7)$$

In output, the program reports the maximum tension that can be absorbed by the tape, the fracture energy and the minimum anchor length, obtained from the relationship:

$$l_{\text{ed}} = \max \left\{ \frac{1}{\gamma_{\text{Rd}} \cdot f_{\text{bd}}} \sqrt{\frac{\pi^2 \cdot E_f \cdot t_f \cdot \Gamma_{\text{Fd}}}{2}}, 200 \text{ mm} \right\}, \quad (4.1)$$

in which $f_{\text{bd}} = \frac{2 \cdot \Gamma_{\text{Fd}}}{s_u}$, con $s_u = 0.25 \text{ mm}$ and $\gamma_{\text{Rd}} = 1.25$.

Checking from pushover analysis

Non-linear static analysis (pushover) needs a global check (performed in ADRS plane by the mash *Extract Data*) and local verifications, carried-out for each element, for brittle (shear) and ductile (flexure) mechanism.

Firstly, for RC structures, it is necessary to globally check the structure with the command *N2 Method* from inside *Extract Data* window, at the item *Base shear X/Y VS Top displX/Y*. Once the performance point has been determined, and hence the displacement demand is known, the closest point of the curve will be used. In such point, local checking will be performed for brittle and ductile mechanisms, directly on data supplied by hinges.

The image shows two windows from a software application. The top window is titled 'Extract data from results' and contains several panels. On the left, there are dropdown menus for 'Select load case or step' (set to 'pushoverX modal') and 'Select time or mode' (set to '1.0029'). The middle panel shows a list of data types, with 'Base shearX VS Top displX' selected. To the right is a table with columns 'Time/Mode', 'Displacement', and 'Value'. The bottom right panel shows an 'ADRS' plot with a red curve and a blue vertical line, with a point labeled 'PP(3.006e-3, 1.983e0)'. The bottom window is titled 'Verification' and contains 'Checking settings' (set to 'Element results', 'pushoverX', '1.0029', 'I and J only', 'EC8_RC_hinge'), a table for 'Limit State OLS 1-DLS 2-LLS 3-CLS 4' (set to '3'), and a table of results. The results table has columns 'ID', 'Case_Time', 'FlexCapacityY', 'FlexCapacityZ', and 'Shear'. The bottom right of the 'Verification' window shows 'Output accuracy' set to '0.00000000'.

Time/Mode	Displacement	Value
2-X	m*	1.228E+002
2-X	Fpart	1.000E+000
2-X	T*	2.446E-001
2-X	Tc*	4.400E-001
2-X	d*	3.243E-003

ID	Case_Time	FlexCapacityY	FlexCapacityZ	Shear
1-J	pushoverX-1.0029	0.00000248	0.00001883	0.18142659
1-I	pushoverX-1.0029	0.00000154	0.00224214	0.17622314
2-J	pushoverX-1.0029	0.00000000	0.00766260	0.15106298
2-I	pushoverX-1.0029	0.00000000	0.00920606	0.17529699
3-J	pushoverX-1.0029	0.00000000	0.00001692	0.17061798
3-I	pushoverX-1.0029	0.00000000	0.00120730	0.18683716
4-I	pushoverX-1.0029	0.00000000	0.00768062	0.15106128
4-J	pushoverX-1.0029	0.00000000	0.00768030	0.15106806
5-J	pushoverX-1.0029	0.00000000	0.00001709	0.17023130
5-I	pushoverX-1.0029	0.00000000	0.00119790	0.18641086
6-J	pushoverX-1.0029	0.00000000	0.00768030	0.15106806
6-I	pushoverX-1.0029	0.00000000	0.00768021	0.15106128
7-J	pushoverX-1.0029	0.00000000	0.00001692	0.17061768
7-I	pushoverX-1.0029	0.00000000	0.00120723	0.18683680
8-I	pushoverX-1.0029	0.00000000	0.00766351	0.15107993

To conduct the verifications, inside the Verification mask, select in order:

- The pushover load case
- "I and J only" as active stations
- The checking set "EC8_RC_hinge"
- The reference Limit State. Life-safety is default
- Optionally, increase the accuracy of table results, to highlight even the lowest Demand/Capacity ratios.

If the global checking has been conducted correctly, the "time/mode" menu is automatically switched to time corresponding to the selected point on pushover curve representing the displacement demand (in the picture above, $t=1.2706$).

For RC structures, the verifications report:

- The ratio between the shear force and the strength, for both local directions y and z;
- The ration between the hinge rotation and the allowable chord rotation related to each single element.

Error codes

Error code description in the "Not processed" column:

- 100 element not processed because of material other than reinforced concrete or reinforcement missing
- 102 material for bars missing
- 103 incorrect bar material (missing design deformations)
- 104 stress exceeds maximum tension
- 105 stress exceeds maximum compression
- 106 (only in case of elastic analysis) $N=0$, analysis not possible in absence of stresses
- 107 (only in the case of elastic analysis) elastic analysis does not converge
- 108 material not set for a solid or hollow figure in section
- 109 (only for timber material) characteristic bending stress f_{mk} missing
- 110 (only for confined sections) brackets not set
- 111 (only for steel-clc composite sections) wrong base material for composite section
- 112 (wood thermal analysis only) wrong cross-section shape - rectangular and circular cross-sections only
- 113 (only for steel-clc composite sections) missing material for section part
- 115 resistance f_k of material not set
- 116 (only for calculation with concrete also tensile) material resistance f_{tk} not set
- 117 deformation e_{c2} missing
- 118 Deformation e_{c3} missing
- 119 deformation e_{cu} missing
- 120 (only for FRP sections) impossible to continue calculation, $E_{psU} < E_{psSy} - E_{ps0}$ (4.7 CNR DT 200)
- 121 (only for FRP sections) impossible to continue calculation, $E_{psU} < E_{psSy} - E_{ps0}$ (4.7 CNR DT 200)
- 121 meshing not succeeded (don't use FRP strips in meshed sections)

Chapter 6

Verifications for timber members

In this chapter, all the verifications performed by *NextFEM Designer* for timber beams are described.

Symbols

A: Area

Jz: Moment of inertia around x-axis

Jy: Moment of inertia around y-axis

Jmin: Minimum moment of inertia

Jt: Torsional Inertia

D: Diameter of circular cross sections

Di: Inner diameter of pipe cross sections

te: Thickness of pipe cross sections

b: Base for any other cross sections

h: Height for any other cross sections

tw: web thickness

tf1: thickness of bottom flange

tf2: thickness of upper flange

t: thickness for planar sections

N: Axial force

Vy: Shear force along y direction

Vz: Shear force along z direction

Mt: Twisting moment

Myy: Moment around y local axis

Mzz: Moment around z local axis

Em: material Young modulus

Gm: material shear modulus

Nlm: material Poisson's ratio

fk: material characteristic strength

W_{eI}Z: section modulus for Z axis

W_{eI}Y: section modulus for Y axis

W_{pI}Z: plastic section modulus for Z axis

W_{pI}Y: plastic section modulus for Y axis

i_z: radius of inertia for Z axis

i_y: radius of inertia for Y axis

i_{min}: minimum radius of inertia

SecType: 1=beam, 2=planar, 0=unknown

SecBeamType: 0=unknown, 1=rectangular, 2=circular, 3=Cshape, 4=Tshape, 5=DoubleTshape, 6=Lspahe, 7=box, 8=pipe

dx: axial relative displacement along beam axis

dy: transversal deflection in local direction y

dz: transversal deflection in local direction z

fc0k: axial compressive strenght parallel to fibres

fc90k: axial compressive strength normal to fibres

ft0k: axial tensile strenght parallel to fibres

f_mk: bending strenght

E₀mean: mean elastic modulus parallel to fibres

E₀₀₅: 5% fractile of elastic modulus parallel to fibres

E₉₀mean: mean elastic modulus normal to fibres

Gmean: mean shear modulus

Verification listing

Verifications performed by *NextFEM Designer* for wooden beams/trusses are described afterwards. Each of them is expressed in terms of usage ratios of the checked section/element:

$$\rho = \frac{E_d}{R_d} = \frac{E_d}{\frac{R_k}{\gamma_M}}$$

with E_d design force

R_d is the design strength, equal to $\frac{R_k}{\gamma_M}$

R_k is the material characteristic strength

γ_M is the partial safety factor the material.

⚠ WARNING: all the verifications cover only beams – walls are not supported.

⚠ WARNING: only beams or columns with rectangular or circular sections are covered. All the other section types are not supported.

Ultimate Limit States

Tension

$$\rho_N = \frac{N}{f_{t0d} A}$$

Compression

$$\rho_N = \frac{-N}{f_{c0d} A}$$

Bending

$$\rho_M = \max \left(\frac{\frac{|M_y|}{W_{el,y}} + k_m \frac{|M_z|}{W_{el,z}}}{f_{md}}, \frac{k_m \frac{|M_y|}{W_{el,y}} + \frac{|M_z|}{W_{el,z}}}{f_{md}} \right)$$

with k_m equal to 0.7 for rectangular sections, 1 otherwise.

Shear

For rectangular sections – less conservative direction

$$\rho_V = \frac{1.5 \max(|V_y|, |V_z|)}{k_{cr} \cdot A \cdot f_{vd}}$$

being k_{cr} the reduction coefficient for section width (default 0.67).

For circular sections – shear resultant

$$\rho_V = \frac{4\sqrt{V_y^2 + V_z^2}}{3k_{cr} \cdot A \cdot f_{vd}}$$

Torsion

For rectangular sections:

$$\rho_T = \frac{|M_t|}{k_{sh} \cdot W_t \cdot f_{vd}}$$

$$\text{with } W_t = \frac{\max(b, h) \cdot \min(b, h)^2}{3 + 1.8 \frac{\min(b, h)}{\max(b, h)}} \quad \text{and} \quad k_{sh} = \min\left(1 + 0.15 \frac{\max(b, h)}{\min(b, h)}, 2\right)$$

For circular sections

$$\rho_T = \frac{|M_t|}{1.2 \cdot W_t \cdot f_{vd}}$$

$$\text{con } W_t = \frac{2J_t}{D}$$

Combined tension and bending

$$\rho_{Tbend} = \max\left(\frac{\frac{N}{A}}{f_{t0d}} + \frac{\frac{|M_y|}{W_{el,y}}}{f_{md}} + k_m \frac{\frac{|M_z|}{W_{el,z}}}{f_{md}}, \frac{\frac{N}{A}}{f_{t0d}} + k_m \frac{\frac{|M_y|}{W_{el,y}}}{f_{md}} + \frac{\frac{|M_z|}{W_{el,z}}}{f_{md}}\right)$$

Combined compression and bending

$$\rho_{Cbend} = \max\left(\left(\frac{\frac{-N}{A}}{f_{c0d}}\right)^2 + \frac{\frac{|M_y|}{W_{el,y}}}{f_{md}} + k_m \frac{\frac{|M_z|}{W_{el,z}}}{f_{md}}, \left(\frac{\frac{-N}{A}}{f_{c0d}}\right)^2 + k_m \frac{\frac{|M_y|}{W_{el,y}}}{f_{md}} + \frac{\frac{|M_z|}{W_{el,z}}}{f_{md}}\right)$$

Stability

For columns:

$$\text{Given } \lambda_{rel} = \frac{\frac{L_0}{i}}{\pi \sqrt{\frac{f_{c0k}}{E_{005}}}} \quad k_{crit} = \begin{cases} 1 & \lambda_{rel} \leq 0.3 \\ \frac{1}{k + \sqrt{k^2 + \lambda_{rel}^2}} & \lambda_{rel} > 0.3 \end{cases}$$

$$k = 0.5(1 + \beta_c(\lambda_{rel} - 0.3) + \lambda_{rel}^2)$$

$$\text{If } \lambda_{rel} \leq 0.3: \rho_{stabC} = \max \left(\left(\frac{\frac{-N}{A}}{k_{crit} \cdot f_{c0d}} \right)^2 + \frac{\frac{|M_y|}{W_{el,y}}}{f_{md}} + k_m \frac{\frac{|M_z|}{W_{el,z}}}{f_{md}}, \left(\frac{\frac{-N}{A}}{k_{crit} \cdot f_{c0d}} \right)^2 + k_m \frac{\frac{|M_y|}{W_{el,y}}}{f_{md}} + \frac{\frac{|M_z|}{W_{el,z}}}{f_{md}} \right)$$

For beams:

$$\lambda_{rel} = \sqrt{\frac{f_{mk}}{\sigma_{m,crit}}} \quad \sigma_{m,crit} = \pi \sqrt{\frac{E_{0.05} J_y G_{0.05} J_t}{k_{eff} L \cdot W_{elZ}}}$$

$$\text{Given } k_{crit} = \begin{cases} 1 & \lambda_{rel} \leq 0.75 \\ 1.56 - 0.75 \lambda_{rel} & 0.75 < \lambda_{rel} \leq 1.4 \\ \frac{1}{\lambda_{rel}^2} & \lambda_{rel} > 1.4 \end{cases}$$

$$\rho_{stab} = \frac{\frac{-N}{A}}{k_c \cdot f_{c0d}} + \left(\frac{\frac{|M_z|}{W_{el,z}}}{f_{md} k_{crit}} \right)^2$$

Ultimate Limit States for CLT panels

Verifications are based on these basic quantities:

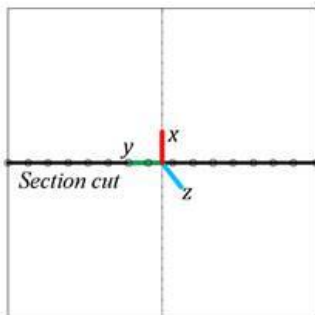

$$\sigma_{N0} = \frac{N}{t \cdot h} \quad \sigma_{M0} = \frac{6|M_{zz}|}{t \cdot h^2}$$

$$\sigma_{Nc} = |\min(\sigma_{N0} - \sigma_{M0}, 0)| \quad \sigma_{Nt} = \max(\sigma_{N0} - \sigma_{M0}, 0)$$

$$\sigma_M = \frac{6|M_{yy}|}{t \cdot h^2} \quad \tau_T = \frac{|M_t|}{J_t} t \quad \tau_{Vz} = 1.5 \frac{|V_z|}{A \cdot k_{cr}} \quad \tau_{Vy} = 1.5 \frac{|V_y|}{A \cdot k_{cr}}$$

Local axes are set by the section cut used for checking.

The shear resistance for gluing is chosen by user f_{gk} - recommended value is

2.5MPa. The rolling shear strength for CLT is assumed as: $f_{RVdCLT} = \min(1MPa, 2f_{t90k}) \frac{k_{mod}}{\gamma_m}$

Axial (with additional check from Teilprojekt-15 (5-45))

$$\rho_N = \max \left(\frac{\sigma_{Nt} + \sigma_M}{f_{t0d} + f_{md}}, \frac{\sigma_{Nc} + \sigma_M}{f_{c0d} + f_{md}}, \frac{\max(\sigma_{Nc}, \sigma_{Nt}) + \sigma_M}{f_{md}} \right)$$

Compression normal to fibres

$$\rho = \frac{\sigma_{Nc} + \sigma_M}{f_{c90d}}$$

Shear-torsion

$$\rho = \left(\frac{\tau_{Vy}}{f_{vd}} \right)^2 + \frac{\tau_T}{k_{sh} \cdot f_{vd}}$$

Shear – out of plane

$$\rho = \frac{\tau_{Vy}}{f_{vd}}$$

Torsion for gluing

$$\rho = \frac{\tau_T}{\frac{k_{mod} \cdot f_{gk}}{\gamma_m}}$$

Rolling Shear

$$\rho = \max \left(\frac{\sigma_{Nt}}{f_{t0d}}, \frac{\sigma_{Nc}}{f_{c0d}} \right) + \frac{\tau_T}{f_{RVdCLT}}$$

Stability

Stability check is carried-out in the same way as for timber columns.

Serviceability Limit States

Strength checks for serviceability limit states are the same as those listed for ultimate limit states.

Deformability checks for serviceability limit states are differentiated in the basis of the service combination type. For characteristic combinations, the total deflection is calculated including viscous effects, as per the following relationship:

$$f_{fin} = f_P (1 + k_{def}) + f_{Q1} (1 + \psi_2 k_{def}) + \sum_i f_{Qi} (\psi_0 + \psi_2 k_{def})$$

In which f_P is the deflection due to permanent loads, f_{Q1} due to principal variable loads, f_{Qi} due to i-th secondary loadcase in the service combination considered.

For the other service combinations, deflection is performed against the specified limit and reported just for completeness under the column “_Deflection”, which is not involved in checking ratio envelopes.

Deflection checks (Deflection)

$$\rho_f = \frac{\sqrt{f_y^2 + f_z^2}}{defLimit}$$

⚠ WARNING: *defLimit* is defined in the initial mask for steel checking, separately for beams and columns. By default, values are set to 1/250 for beams (*defTR*) and 1/300 for columns (*defCOL*).

Macroelement for CLT and fastener checks

Starting with version 2.7, X-Lam panels can be represented using the CLTwall macroelement.

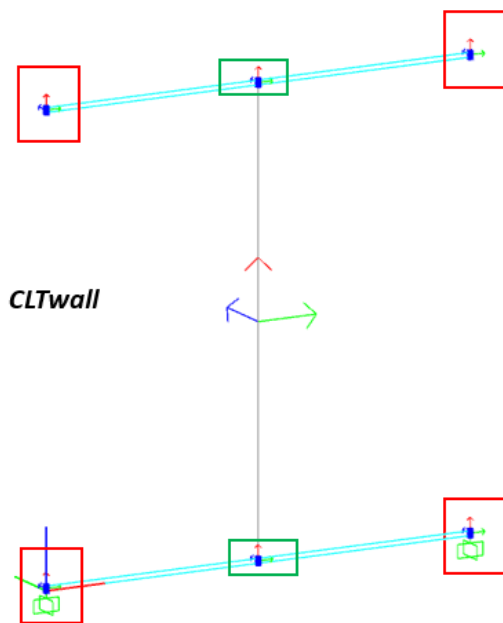

This macroelement consists of a macroelement similar to wall, with 2 layers of springs (lower and upper).

It consists of:

- Xlam panel with beam behavior
- HD springs (hold-down or tie-down) with tensile/compressive response
- AB springs (angle brackets) with shear response

Regardless of the constraints adopted at the base (e.g., joints), the panel is unstable outside its plane due to the need to adopt a box-type structure for Xlam buildings.

Vertical joints between X-Lam panels can be represented using the CLTjoint macroelement.

It consists of VJ (vertical joint) springs with shear response, each representing half the stiffness of the screw joint between CLTwall walls.

The macroelement must be positioned between CLTwall walls and cannot be used on its own because it is unstable. To facilitate positioning, divide the original CLTwall using the Modify / Split and Join command.

The macroelement is assigned from the Element Properties in the context menu (right double-click in the viewport) or from the Assign menu.

The following properties must be assigned for each CLTwall or CLTjoint macroelement:

- For CLTwall, the *dowelsHD* property indicates the number of pre-drilled screws or nails or screws for each hold-down or tie-down.
- For CLTwall, the *dowelsAB* property indicates the total number of screws or nails for all bottom or top angles.



CLTjoint



- For CLTjoint, the dowelsVJ property indicates the total number of screws or nails along the joint between walls.

- For CLTwall and CLTjoint, the dowelsD property indicates the diameter of the connectors (nails or screws). This parameter is unique, assuming that the same nails/screws are used for the entire wall.

These properties can be assigned to the entire model (walls + joints); the properties do not conflict (CLTwall does not use dowelsVJ, and CLTjoint does not use dowelsAB/HD).

The data will be used to calculate the stiffness of the connectors for analysis. Stiffness is evaluated according to EC5 7.1. The stiffness calculation procedure disregards the EC5 side note so as not to have to assume a different stiffness for the Ultimate Limit States.

npr=0 -> Dowels, screws, pre-drilled nails

npr=1 .> Nails without predrilling

The resistant calculation is performed in accordance with Eurocode 5 8.2.3. The term Fax,Rk (extraction) is assumed to be zero as a precaution.

- thin steel plate, single shear plane:

$$F_{v,Rk} = \min. \begin{cases} 0,4f_{h,k}t_1d & \text{(a)} \\ 1,15\sqrt{2M_{y,Rk}f_{h,k}d} + \frac{F_{ax,Rk}}{4} & \text{(b)} \end{cases}$$

- thick steel plate, single shear plane

$$F_{v,Rk} = \min. \begin{cases} f_{h,k}t_1d & \text{(c)} \\ f_{h,k}t_1d \left[\sqrt{2 + \frac{4M_{y,Rk}}{f_{h,k}dt_1^2}} - 1 \right] + \frac{F_{ax,Rk}}{4} & \text{(d)} \\ 2,3\sqrt{M_{y,Rk}f_{h,k}d} + \frac{F_{ax,Rk}}{4} & \text{(e)} \end{cases}$$

The resistance, calculated according to Johansen's theory, uses the following values:

$$M_{y,Rk} = 0,3 \cdot f_u \cdot d^{2,6}$$

- Characteristic yield moment:

where d = nail diameter; for screws, always specify the internal diameter. For

$$f_{h,k} = 0,082 \cdot (1 - 0,01d) \cdot \rho_k \quad [N/mm^2]$$

- Characteristic resistance to re-punching:

To verify the connections, select the CLTwall verification set and only one station per element (I, M, or J).

Also set the parameters for verification described below.

The screenshot shows the 'Verification' software interface. On the left, the 'Checking settings' panel is visible, with several fields highlighted by red boxes: 'only' in the 'for time/mode' dropdown, 'CLTwall' in the 'Built-in checking' dropdown, and a table of parameters for fastener checking for CLT walls as per EN 1995-1-1. The table includes fields for 'Steel plate thickness [mm]' (tp=3), 'Ultimate connector strength [MPa]' (fuk=580), 'Service class (1,2,3)' (SCL=2), and 'Use non-predrilled nails [0/1]' (npr=0). The 'Text output for selected item' panel shows a list of parameters for a selected item. The main area on the right is a table with columns: ID, Case_Time, Shear_ABbot, Shear_ABtop, Tension_HDbot, Tension_HDtop, and Shear_Joint. The table contains 20 rows of data for various cases (10228-I to 10243-I). At the bottom, there are options for 'Show not verified only', 'Output accuracy', and 'Units in kN, m, °C'.

Please set:

- the thickness of the metal plates of angle brackets and hold-downs, in mm
- the ultimate strength of the steel of the angle bracket or hold-down connector, in MPa
- the service class (1, 2, or 3)
- the flag to consider nails without pre-drilling instead of screws

VERIFICATION COLUMN LEGEND:

- bot/top suffix for bottom and top
- AB angle bracket
- HD hold-down or tie-down (tension verification only)
- Shear_Joint shear joint between walls

Any verification errors or missing results are highlighted in red (*Unprocessed* column with value 100).

Chapter 7

Verifications for thin steel profiles

In this chapter, all the verifications performed by *NextFEM Designer* for thin profiles (*cold-formed profiles*) as per Eurocode 3 part 1-3 are described.

Symbols

A: Area

Jz: Moment of inertia around x-axis

Jy: Moment of inertia around y-axis

Jmin: Minimum moment of inertia

Jt: Torsional Inertia

D: Diameter of circular cross sections

Di: Inner diameter of pipe cross sections

te: Thickness of pipe cross sections

b: Base for any other cross sections

h: Height for any other cross sections

tw: web thickness

tf1: thickness of bottom flange

tf2: thickness of upper flange

t: thickness for planar sections

N: Axial force

Vy: Shear force along y direction

Vz: Shear force along z direction

Mt: Twisting moment

Myy: Moment around y local axis

Mzz: Moment around z local axis

Em: material Young modulus

Gm: material shear modulus

Nlm: material Poisson's ratio

fk: material characteristic strength

WelZ: section modulus for Z axis

WelY: section modulus for Y axis

WplZ: plastic section modulus for Z axis

WplY: plastic section modulus for Y axis

iz: radius of inertia for Z axis

iy: radius of inertia for Y axis

imin: minimum radius of inertia

SecType: 1=beam, 2=planar, 0=unknown

SecBeamType: 0=unknown, 1=rectangular, 2=circular, 3=Cshape, 4=Tshape, 5=DoubleTshape, 6=Lspahe, 7=box, 8=pipe

dx: axial relative displacement along beam axis

dy: transversal deflection in local direction y

dz: transversal deflection in local direction z

Verification listing

Verifications performed by *NextFEM Designer* for steel beams/trusses are described afterwards. Each of them is expressed in terms of usage ratios of the checked section/element:

$$\rho = \frac{E_d}{R_d} = \frac{E_d}{\frac{R_k}{\gamma_M}}$$

with E_d design force

R_d is the design strength, equal to $\frac{R_k}{\gamma_M}$

R_k is the material characteristic strength

γ_M is the partial safety factor the material.

⚠ WARNING: all the verifications listed refer to transversal sections of Class 3 or 4. Plastic capacity, typically considered in Class 1 or 2 sections, are not taken into account for such profiles.

Base assumptions

Thin sections are represented by a series of points describing their piecewise middle line. Such kind of sections can be defined by adding a property set called "Cold formed" in the Properties tab of section properties. Requested data are the thickness t_w and the radius of curvature r_c .

The screenshot shows the software interface for defining section properties. The 'General' tab is at the top, with 'Name' set to 'omega140x120x50_copy' and 'Angle' set to '0.00'. The 'Properties' tab is active, showing a list of properties with 'tw' and 'rc' checked. The 'tw' property has a value of 1.000E+000 and 'rc' has a value of 1.000E+003. A graph on the right shows a cross-section of a cold-formed profile with a green dot at the center.

Auto	Prop. name	Value
<input type="checkbox"/>	A	4.815E+002
<input type="checkbox"/>	Avy	1.693E+004
<input type="checkbox"/>	Avz	1.693E+004
<input type="checkbox"/>	Jy	2.349E+006
<input type="checkbox"/>	Jz	1.152E+006
<input type="checkbox"/>	Jyz	0.000E+000
<input type="checkbox"/>	Jt	1.605E+002
<input type="checkbox"/>	CenterY	6.532E+001
<input type="checkbox"/>	CenterZ	1.203E+002
<input checked="" type="checkbox"/>	tw	1.000E+000
<input checked="" type="checkbox"/>	rc	1.000E+003

ID	Points	Type
1	6	filled

As an alternative, an existing section can be converted to thin profile by the command in the *Section* window right click/Convert to/Cold-formed profile.

Section that can be converted are:

- C
- L
- Double C
- Double L
- Omega
- Omega with negative d parameter, alias C with reinforced flanges
- Boxed.

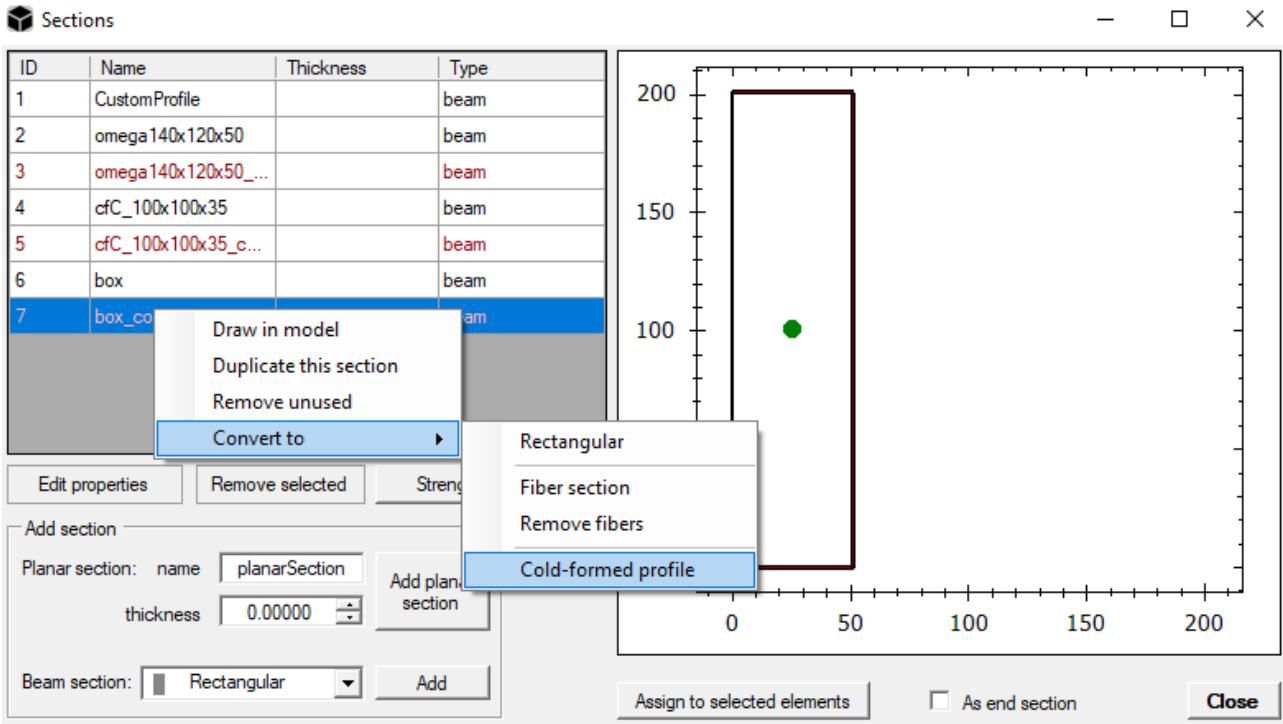

Estimation of section class

Conservatively, each section class is estimated as the maximum section class amongst the ones related to each part of the section, considered as fully compressed. Each single edge is evaluated separately, distinguishing between internal and external parts. The profile class is the maximum amongst all edges.

Part	Ratio	Class 1	Class 2	Class 3	Class 4
external	b_{eff}/t_w	9ε	10ε	14ε	/
internal	b_{eff}/t_w	33ε	38ε	42ε	/

$$\text{with } \varepsilon = \sqrt{\frac{235}{f_y}}$$

Effective lengths b_{eff} for each segment are calculated assuming each edge in compression, while warping coefficients are taken as 0.43 for external parts and 4 for internal parts.

The strength of material is always taken as the base one (noted with f_y in EC3-1-3).

Partial safety coefficients are taken, without user modification, as:

$$\gamma_{M0} = 1$$

$$\gamma_{M1} = 1$$

$$\gamma_{M2} = 1.25$$

The column name of the program output is reported between brackets (i.e. (Axial))

Tension/compression (Axial)

In tension:

$$\rho_N = \frac{N}{N_{Rd}} = \frac{N}{\frac{A f_{yk}}{\gamma_{M0}}}$$

In compression (Eulerian buckling):

$$\rho_{Nb} = \frac{N}{N_{b,Rd}} = \frac{N}{\frac{\chi_{\min} A f_{yk}}{\gamma_{M1}}}$$

with χ_{\min} calculated on the base of the following buckling coefficients:

Type of section	α_y	α_z	α_{LT}
all	0.49	0.49	0.76

Shear (Shear)

$$\text{For web: } \rho_V = \frac{V}{V_{Rd}} = \frac{V}{0.346 \frac{h_w}{t_w} \sqrt{\frac{f_y}{E_m}}}$$

$$\text{For flanges: } \rho_V = \frac{V}{V_{Rd}} = \frac{V}{\frac{b_w \cdot t_w}{\gamma_{m0}} f_{bv}} \text{ with } f_{bv} \text{ as reduced shear strength.}$$

Bending with shear interaction (Bending)

$$\rho_{Mrid} = \frac{M}{\alpha_{PL} \cdot W \cdot f_{yk} \cdot \cos(\rho_N)} = \frac{M}{M_{Rd} \cdot \cos(\rho_N)} \text{ if the shear force does not exceed the 30\% of plastic strength;}$$

$$\rho_{Mrid} = \frac{M}{M_{Rd,red}}, \text{ with } M_{Rd,red} = M_{Rd} (1 - \min((2\rho_V - 1)^2, 1)) \text{ if the shear force exceeds the 50\% of plastic strength, } M_{Rd,red} = M_{Rd} \text{ otherwise.}$$

Biaxial bending and axial load (BuckBending_biax and TensBending_biax)

If the element is compressed:

$$\rho_{MNb} = \frac{\rho_N}{\chi_{\min}} + \frac{\rho_{M_y}}{r_{ridN_{cr}}} + \frac{\rho_{M_z}}{r_{ridN_{cr}}} \text{ with } r_{ridN_{cr}} = 1 - \frac{\rho_N \bar{\lambda}^2}{\gamma_{M0}}$$

If the element is tensioned:

$$\rho_{MNb} = \rho_N + \rho_{M_y} + \rho_{M_z}$$

Torsional buckling (TorsionBuckling)

$$\rho_{MTb} = \frac{M}{M_{b,Rd}} = \frac{M}{\frac{\chi_{LT} A \cdot W_{pl} \cdot f_k}{\gamma_{M1}}}$$

For torsional buckling, the second-order twisting moment is a function of warping constant:

$$M_{cr} = \psi \frac{\pi}{L_{0b}} \sqrt{EI_y \cdot GI_T} \sqrt{1 + \left(\frac{\pi}{L_{0b}}\right)^2 \cdot \frac{EI_\omega}{GI_T}}$$

In evaluating the critical resisting moment, the coefficient ψ is forced to the value 1.127 if the beam has null moments at both ends. In any case, it is limited to 1.285.

Combined torsional buckling (TorsionBuck_comb)

$$\rho_{MNb} = \frac{\rho_N}{\chi_{\min}} + \frac{\rho_{M_y}}{\chi_{LT} \cdot r_{ridN_{cr}}} + \frac{\rho_{M_z}}{r_{ridN_{cr}}} \quad \text{and} \quad \rho_{MNb} = \frac{\rho_N}{\chi_{\min}} + \frac{\rho_{M_y}}{r_{ridN_{cr}}} + \frac{\rho_{M_z}}{\chi_{LT} \cdot r_{ridN_{cr}}} \quad (\text{for rotated sections})$$

Deflection checks

Deflection checks (Deflection)

$$\rho_f = \frac{\sqrt{f_y^2 + f_z^2}}{defLimit}$$

⚠ WARNING: *defLimit* is defined in the initial mask for steel checking, separately for beams and columns. By default, values are set to 1/250 for beams (*defTR*) and 1/300 for columns (*defCOL*).

Cold-formed steel profiles as per Eurocode 3-1-3

Maximum beam deformation	
defTR	0.004
Maximum column deformation	
defCOL	0.00333

Chapter 8

Verifications for thin aluminium alloy profiles

In this chapter, all the verifications performed by *NextFEM Designer* for thin profiles (*cold-formed profiles*) as per Eurocode 9 part 1-4 are described.

Symbols

A: Area
Jz: Moment of inertia around x-axis
Jy: Moment of inertia around y-axis
Jmin: Minimum moment of inertia
Jt: Torsional Inertia
D: Diameter of circular cross sections
Di: Inner diameter of pipe cross sections
te: Thickness of pipe cross sections
b: Base for any other cross sections
h: Height for any other cross sections
tw: web thickness
tf1: thickness of bottom flange
tf2: thickness of upper flange
t: thickness for planar sections
N: Axial force
Vy: Shear force along y direction
Vz: Shear force along z direction
Mt: Twisting moment
Myy: Moment around y local axis
Mzz: Moment around z local axis
Em: material Young modulus
Gm: material shear modulus
Nlm: **material Poisson's ratio**
fk: material characteristic strength
WelZ: section modulus for Z axis
WelY: section modulus for Y axis
WplZ: plastic section modulus for Z axis
WplY: plastic section modulus for Y axis
iz: radius of inertia for Z axis
iy: radius of inertia for Y axis
imin: minimum radius of inertia
SecType: 1=beam, 2=planar, 0=unknown
SecBeamType: 0=unknown, 1=rectangular, 2=circular, 3=Cshape, 4=Tshape, 5=DoubleTshape, 6=Lspahe, 7=box, 8=pipe
dx: axial relative displacement along beam axis
dy: transversal deflection in local direction y
dz: transversal deflection in local direction z

Verification listing

Verifications performed by *NextFEM Designer* for beams/trusses are described afterwards. Each of them is expressed in terms of usage ratios of the checked section/element:

$$\rho = \frac{E_d}{R_d} = \frac{E_d}{\frac{R_k}{\gamma_M}}$$

with E_d design force

R_d is the design strength, equal to $\frac{R_k}{\gamma_M}$

R_k is the material characteristic strength

γ_M is the partial safety factor the material.

⚠ WARNING: all the verifications listed refer to transversal sections of Class 3 or 4. Plastic capacity, typically considered in Class 1 or 2 sections, are not considered for such profiles.

Base assumptions

Thin sections are represented by a series of points describing their piecewise middle line. Such kind of sections can be defined by adding a property set called "Cold formed" in the Properties tab of section properties. Requested data are the thickness t_w and the radius of curvature r_c .

The screenshot shows a software window with two main panels. The left panel is a 'General' tab with a 'Properties' sub-tab. It contains a table of properties and a list of checked properties.

Auto	Prop. name	Value
<input type="checkbox"/>	A	4.815E+002
<input type="checkbox"/>	Avy	1.693E+004
<input type="checkbox"/>	Avz	1.693E+004
<input type="checkbox"/>	Jy	2.349E+006
<input type="checkbox"/>	Jz	1.152E+006
<input type="checkbox"/>	Jyz	0.000E+000
<input type="checkbox"/>	Jt	1.605E+002
<input type="checkbox"/>	CenterY	6.532E+001
<input type="checkbox"/>	CenterZ	1.203E+002
<input checked="" type="checkbox"/>	tw	1.000E+000
<input checked="" type="checkbox"/>	rc	1.000E+003

Below the table, the 'Add properties set' dropdown is set to 'Cold formed'. The right panel shows a graphical representation of a thin profile on a coordinate system. The x-axis ranges from 0 to 250, and the y-axis ranges from 0 to 250. The profile is a rectangle with a width of approximately 140 and a height of approximately 120. A green dot is located at approximately (120, 70). The window also has buttons for 'Assign to selected elements', 'As end section', 'Close', 'OK', and 'Cancel'.

As an alternative, an existing section can be converted to thin profile by the command in the *Section* window right click/Convert to/Cold-formed profile.

Section that can be converted are:

- C
- L
- Double C
- Double L
- Omega
- Omega with negative d parameter, alias C with reinforced flanges
- Boxed.

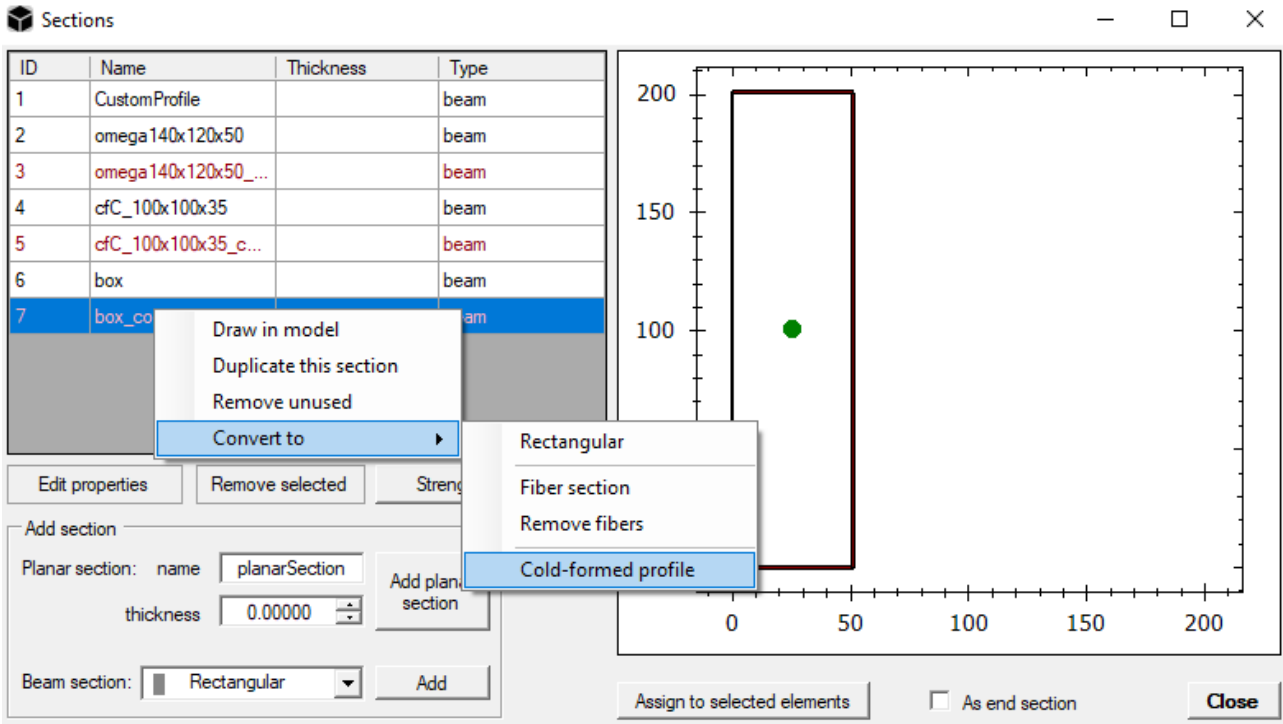

Estimation of section class

Conservatively, each section class is estimated as the maximum section class amongst the ones related to each part of the section, considered as fully compressed. Each single edge is evaluated separately, distinguishing between internal and external parts. The profile class is the maximum amongst all edges.

Part	Ratio	Class 1	Class 2	Class 3	Class 4
external	b_{eff}/t_w	β_1	β_2	β_3	/
internal	b_{eff}/t_w	β_1	β_2	β_3	/

The values β_1 , β_2 , β_3 are computed automatically by considering the ratios β/ε reported on the following table and multiplied by the parameter ε defined as follows:

$$\varepsilon = \sqrt{\frac{250}{f_0}}$$

Effective lengths b_{eff} for each segment are calculated assuming each edge in compression, while warping coefficients are taken as 0.43 for external parts and 4 for internal parts.

The strength of material is always taken as the base one (noted with f_0 or f_{0HAZ} in EC9-1-4, denoted in the following as f_y).

Partial safety coefficients are taken, without user modification, as:

$$\gamma_{M0} = 1.1$$

$$\gamma_{M1} = 1.1$$

$$\gamma_{M2} = 1.25$$

The column name in the output table is reported between brackets (i.e. (Axial))

Tension/compression (Axial)

In tension:

$$\rho_N = \frac{N}{N_{Rd}} = \frac{N}{\frac{Af_{yk}}{\gamma_{M0}}}$$

In compression (Eulerian buckling):

$$\rho_{Nb} = \frac{N}{N_{b,Rd}} = \frac{N}{\frac{\chi_{\min} Af_{yk}}{\gamma_{M1}}}$$

with χ_{\min} calculated on the base of the following buckling coefficients:

Type of section	α_y	α_z	α_{LT}
all	0.49	0.49	0.76

Shear (Shear)

$$\text{For web: } \rho_V = \frac{V}{V_{Rd}} = \frac{V}{0.346 \frac{h_w}{t_w} \sqrt{\frac{f_y}{E_m}}}$$

$$\text{For flanges: } \rho_V = \frac{V}{V_{Rd}} = \frac{V}{\frac{b_w \cdot t_w}{\gamma_{m0}} f_{bv}} \text{ with } f_{bv} \text{ as reduced shear strength.}$$

Bending with shear interaction (Bending)

$$\rho_{Mrid} = \frac{M}{\alpha_{PL} \cdot W \cdot f_{yk} \cdot \cos(\rho_N)} = \frac{M}{M_{Rd} \cdot \cos(\rho_N)} \text{ if the shear force does not exceed the 30\% of plastic strength;}$$

$$\rho_{Mrid} = \frac{M}{M_{Rd,red}}, \text{ with } M_{Rd,red} = M_{Rd} (1 - \min((2\rho_V - 1)^2, 1)) \text{ if the shear force exceeds the 50\% of plastic strength, } M_{Rd,red} = M_{Rd} \text{ otherwise.}$$

Biaxial bending and axial load (BuckBending_biax and TensBending_biax)

If the element is compressed:

$$\rho_{MNb} = \frac{\rho_N}{\chi_{\min}} + \frac{\rho_{M_y}}{r_{ridN_{cr}}} + \frac{\rho_{M_z}}{r_{ridN_{cr}}} \text{ with } r_{ridN_{cr}} = 1 - \frac{\rho_N \bar{\lambda}^2}{\gamma_{M0}}$$

If the element is tensioned:

$$\rho_{MNb} = \rho_N + \rho_{M_y} + \rho_{M_z}$$

Torsional buckling (TorsionBuckling)

$$\rho_{MTb} = \frac{M}{M_{b,Rd}} = \frac{M}{\frac{\chi_{LT} \cdot A \cdot W_{pl} \cdot f_k}{\gamma_{M1}}}$$

For torsional buckling, the second-order twisting moment is a function of warping constant:

$$M_{cr} = \psi \frac{\pi}{L_{0b}} \sqrt{EI_y \cdot GI_T} \sqrt{1 + \left(\frac{\pi}{L_{0b}}\right)^2 \cdot \frac{EI_\omega}{GI_T}}$$

In evaluating the critical resisting moment, the coefficient ψ is forced to the value 1.127 if the beam has null moments at both ends. In any case, it is limited to 1.285.

Combined torsional buckling (*TorsionBuck_comb*)

$$\rho_{MNb} = \frac{\rho_N}{\chi_{\min}} + \frac{\rho_{M_y}}{\chi_{LT} \cdot r_{ridN_{cr}}} + \frac{\rho_{M_z}}{r_{ridN_{cr}}} \quad \text{and} \quad \rho_{MNb} = \frac{\rho_N}{\chi_{\min}} + \frac{\rho_{M_y}}{r_{ridN_{cr}}} + \frac{\rho_{M_z}}{\chi_{LT} \cdot r_{ridN_{cr}}} \quad (\text{for rotated sections})$$

Deflection checks

Deflection checks (*Deflection*)

$$\rho_f = \frac{\sqrt{f_y^2 + f_z^2}}{defLimit}$$

⚠ WARNING: *defLimit* is defined in the initial mask for checking, separately for beams and columns. By default, values are set to 1/250 for beams (*defTR*) and 1/300 for columns (*defCOL*).

Built-in checking Cold Formed Alu ☰

Cold-formed aluminium alloy profiles as per Eurocode 9-1-4

Maximum beam deformation	
defTR	0.004
Maximum column deformation	
defCOL	0.00333

Chapter 9

Verifications for masonry structures

In this chapter, all the verifications performed by *NextFEM Designer* for masonry structures as per Eurocode 6 part 1-1 and Eurocode 8 part 3 are described.

Symbols

A: Area
Jz: Moment of inertia around x-axis
Jy: Moment of inertia around y-axis
Jmin: Minimum moment of inertia
Jt: Torsional Inertia
D: Diameter of circular cross sections
Di: Inner diameter of pipe cross sections
te: Thickness of pipe cross sections
b: Base for any other cross sections
h: Height for any other cross sections
tw: web thickness
tf1: thickness of bottom flange
tf2: thickness of upper flange
t: thickness for planar sections
N: Axial force
Vy: Shear force along y direction
Vz: Shear force along z direction
Mt: Twisting moment
Myy: Moment around y local axis
Mzz: Moment around z local axis
Em: material Young modulus
Gm: material shear modulus
Nlm: material Poisson's ratio
fk: material characteristic strength
WelZ: section modulus for Z axis
WelY: section modulus for Y axis
WplZ: plastic section modulus for Z axis
WplY: plastic section modulus for Y axis
iz: radius of inertia for Z axis
iy: radius of inertia for Y axis
imin: minimum radius of inertia
t: wall thickness
bm: wall length

Verification listing

Verifications performed by *NextFEM Designer* are described afterwards. Each of them is expressed in terms of usage ratios of the checked section/element:

$$\rho = \frac{E_d}{R_d} = \frac{E_d}{\frac{R_k}{\gamma_M}}$$

with E_d design force

R_d is the design strength, equal to $\frac{R_k}{\gamma_M}$

R_k is the material characteristic strength

γ_M is the partial safety factor the material.

Tensile failure (TensileFailure)

$$\rho_N = \frac{|N|}{t \cdot b_m \cdot f_{td}}$$

Vertical load stability (Axial)

$$\rho_N = \frac{N}{\phi \cdot t \cdot b_m \cdot f_d}$$

with ϕ a reduction factor evaluated as follows:

- for half-span station: $\phi = 1 - \frac{2}{t} \max\left(\frac{M_{yy}}{N} + \frac{L}{450}, 0.05t\right)$

- for other stations: $\phi = A1 \cdot e^{\left(-\frac{u^2}{2}\right)}$, as described in EC6 §6.1.2

In-plane bending (InPlaneBending)

$$\rho_{PF} = \frac{M_{zz}}{\frac{b_m \cdot N}{2} \cdot N \left(1 - \frac{1.15N}{b_m \cdot t \cdot f_d}\right)}$$
 as in EC8-3 C.4.2.1

Out-of-plane bending (OutOfPlaneBending)

$$\rho_{PF} = \frac{M_{yy}}{\frac{t \cdot N}{2} \cdot N \left(1 - \frac{1.15N}{b_m \cdot t \cdot f_d}\right)}$$
 as in EC8-3 C.4.2.1

Sliding shear (Shear)

$$\rho_V = \frac{Vy}{f_{vd} \cdot b1 \cdot t}$$

with $f_{vd} = f_{vd0} + 0.4 \frac{N}{b_1 \cdot t}$ and compressed length $b_1 = \beta \cdot b_m$:

$$\beta = \begin{cases} 1 & \text{if } \frac{6 \cdot eb}{b_m} \leq 1 \\ \frac{3}{2} - \frac{3 \cdot eb}{b_m} & \text{if } \frac{3 \cdot eb}{b_m} \leq \frac{3}{2} \\ 0 & \text{otherwise} \end{cases}$$

For spandrels:

$$\rho_V = \frac{V_y}{b_m \cdot t \cdot f_{vd0}}$$

Reinforced masonry

Bending

Reinforced masonry panels are checked for in-plane and out-of-plane bending by calculating analytically their reinforced section.

Shear

$$\rho_{Vy} = \frac{|V_y|}{\min \left(b_1 \cdot t \left(f_{vd0} + 0.4 \frac{N}{d_z \cdot t} \right), b_1 \cdot t \cdot f_{vd} + 0.9 A_{swY} f_{yds} \right)}$$

Checking from pushover analysis

Non-linear static analysis (pushover) needs a global check (performed in ADRS plane by the mash *Extract Data*).

For masonry structures, it is necessary to globally check the structure with the command *N2 Method* from inside *Extract Data* window, at the item *Base shear X/Y VS Top dispX/Y*. Once the performance point has been determined, and hence the displacement demand is known, the closest point of the curve will be used.

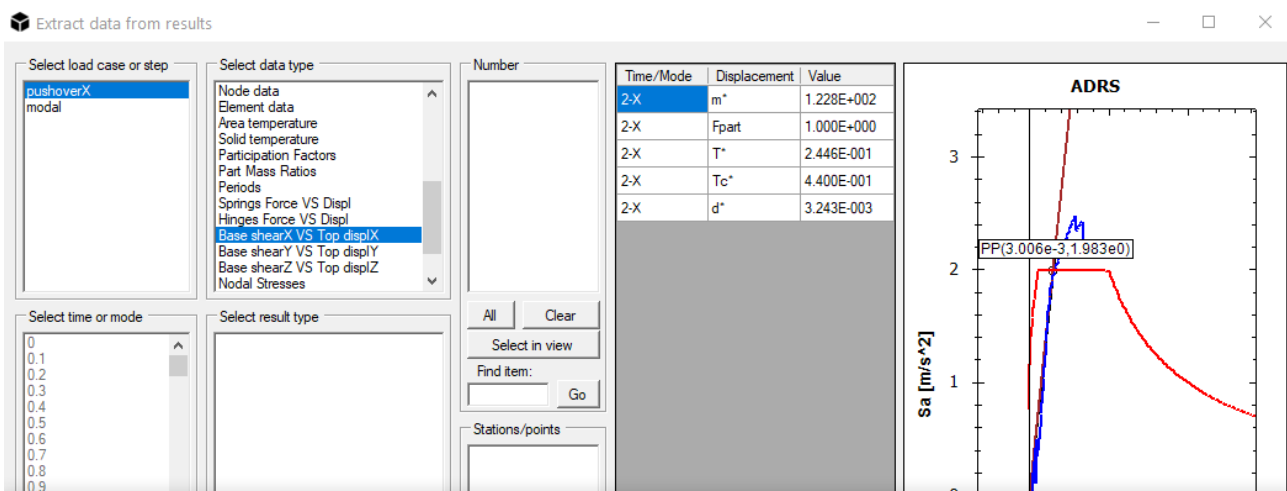

Non-linear capacity can be calculated in *NextFEM Designer* by 2 approaches:

- By using plastic hinges at both ends of piers and spandrels;
- My means of *masonryWall* macroelements, available only for bi-dimensional modelling of panels.

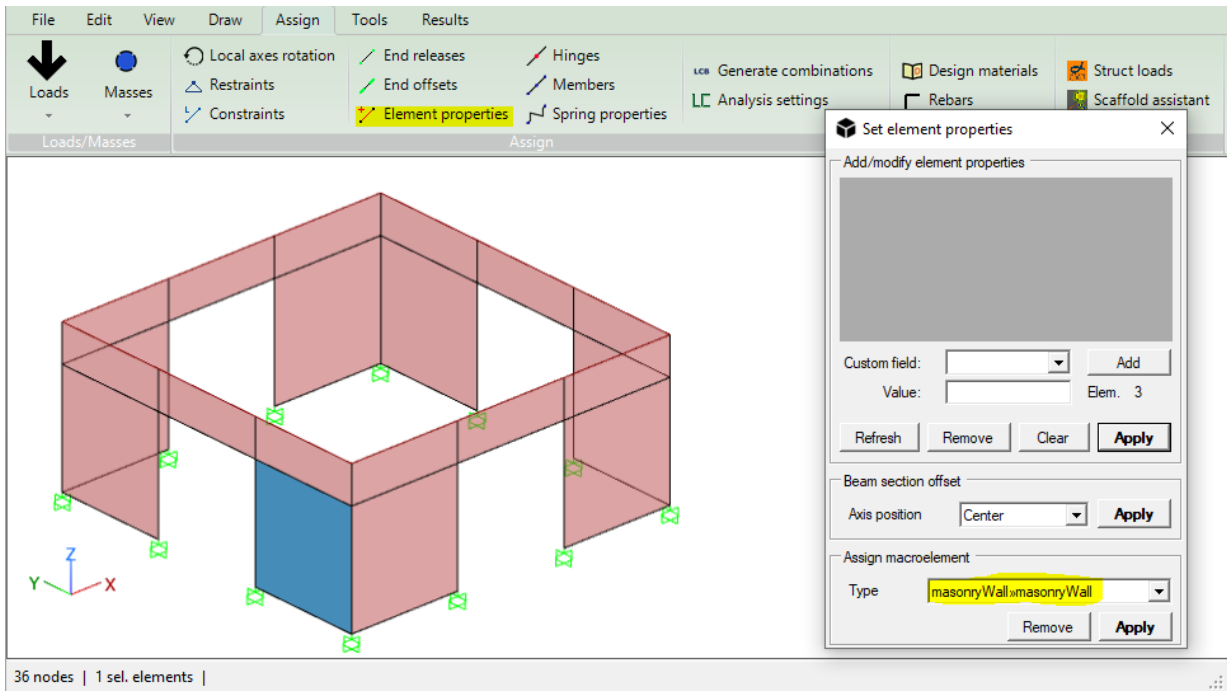

Plastic hinges are defined by means of the following quantities:

Local DoF	Corresponding action	Strength	Ductility (*)	Ultimate displ./rot. (**)
1	N (tension)	$f_{td} * A$	/	/
1	N (compression)	Nrd from stability	1.5	ductility of 1.5
2	Vy	in-plane Vrd	2.5	0.005h (0.008h with rebars)
3	Vz	$b_m * t * f_{vd0}$	2.5	0.005h (0.008h with rebars)
4	Mt	$f_{vd0} * W_t$	/	/
5	Myy	out-of-plane Mrd	5	0.01 (0.016 with rebars)
6	Mzz	in-plane Mrd	5	0.01 (0.016 with rebars)

(*) up to version 2.6

(**) from version 2.7

For cyclic analyses, plastic hinges follow a peak-oriented behaviour and keep the strength level of the cracking (it means resisting shear is not updated with axial load dynamically after elastic limit).

The *masonryWall* macroelement determines the strength as in the following:

- for piers, as the minimum between rocking (bending), sliding and diagonal cracking shear (for the latter, Turnsek-Cacovic formulation is adopted), evaluated at each increment as a function of the concurrent axial load. To exclude a mechanism, set to zero the corresponding strength in the material properties (f_k , f_{v0} and t_0 , f_{tu} , respectively);
- for spandrels, the maximum between the pure shear strength ($b_m * t * f_{v0}$) and the diagonal cracking shear evaluated at each increment as a function of the concurrent axial load.

They exhibit in-plane and out-of-plane non-linear behaviour:

- Ultimate displacement by default is 0.005 L for shear mechanisms; it can be changed by adding the value **"Du"** as custom material property;
- **Ultimate rotation by default is 0.01 for rocking mechanism; it can be changed by adding the value "Ru"** as custom material property.

The usage of this macroelement is advised for pushover, cyclic and dynamic analyses.